



Ethernet/IEEE 802.3 evolution

Mario Baldi

Politecnico di Torino

<http://staff.polito.it/mario.baldi>

Pietro Nicoletti

Studio Reti

<http://www.studioreti.it>

Based on chapter 3 of:

M. Baldi, P. Nicoletti, "Switched LAN", McGraw-Hill, 2002, ISBN 88-386-3426-2

Copyright Notice

This set of transparencies, hereinafter referred to as slides, is protected by copyright laws and provisions of International Treaties. The title and copyright regarding the slides (including, but not limited to, each and every image, photography, animation, video, audio, music and text) are property of the authors specified on page 1.

The slides may be reproduced and used freely by research institutes, schools and Universities for non-profit, institutional purposes. In such cases, no authorization is requested.

Any total or partial use or reproduction (including, but not limited to, reproduction on magnetic media, computer networks, and printed reproduction) is forbidden, unless explicitly authorized by the authors by means of written license.

Information included in these slides is deemed as accurate at the date of publication. Such information is supplied for merely educational purposes and may not be used in designing systems, products, networks, etc. In any case, these slides are subject to changes without any previous notice. The authors do not assume any responsibility for the contents of these slides (including, but not limited to, accuracy, completeness, enforceability, updated-ness of information hereinafter provided).

In any case, accordance with information hereinafter included must not be declared.

In any case, this copyright notice must never be removed and must be reported even in partial uses.

Fast Ethernet - IEEE 802.3u

- IEEE 802.3u
 - Ethernet 802.3 evolution of 10BASE-T e 10BASE-F
- 4 sub-standard for different cable type:
 - 100BASE-T4 (UTP cat 3, over 4 pairs)
 - 100BASE-T2 (UTP cat 3, over 2 pairs)
 - 100BASE-TX (UTP cat 5, over 2 pairs)
 - 100BASE-FX (fiber optic)
- Same MAC CSMA/CD of IEEE 802.3
- Same frame format of IEEE 802.3
- More than 200 vendors have successfully implemented the 10Base-T standard

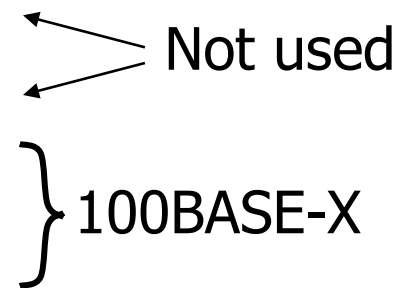

Architectural Model

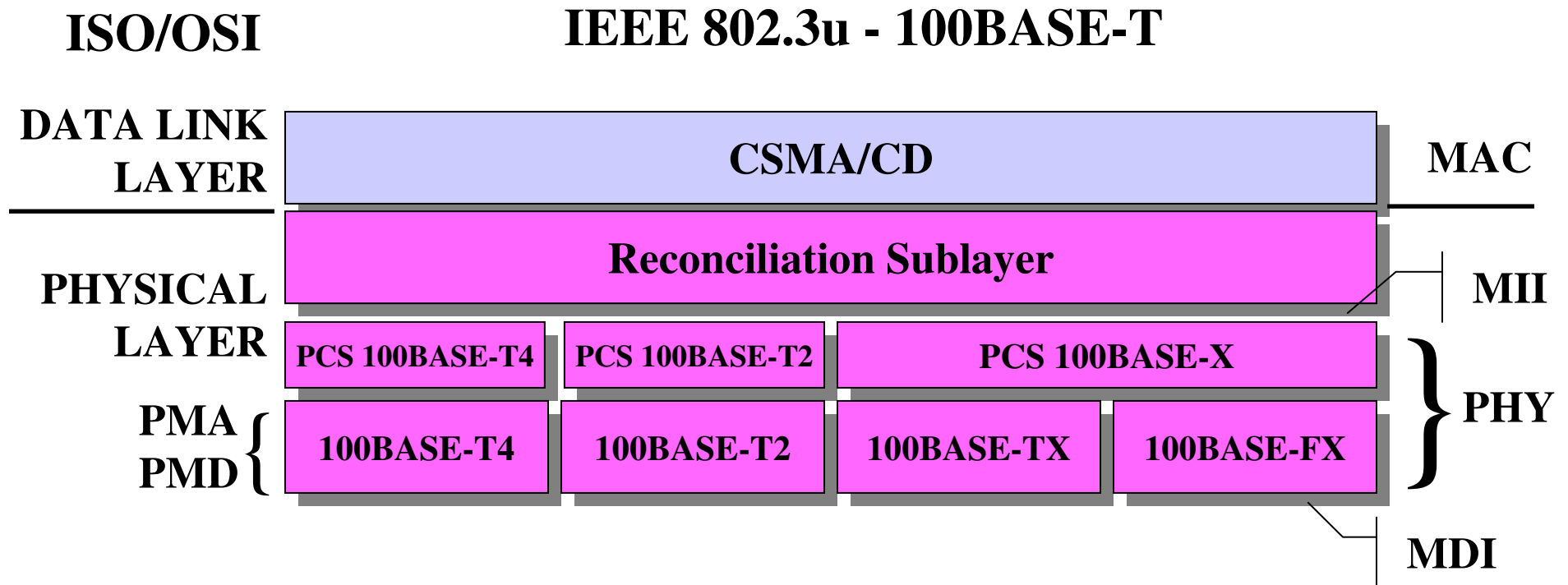

MDI: Medium Dependent Interface
 MII: Medium Independent Interface
 PCS: Physical Coding Sublayer

PHY: Physical Layer Device
 PMA: Physical Medium Attachment
 PMD: Physical Medium Dependent

LAN extension and limits

- Speed 10 times faster
 - Data Rate 100Mb/s
 - Bit time 10ns
 - Interpacket gap 0.96 μ s
 - Slot time 512 bit (5.12 μ s)
- Reduced LAN diameter (200 m + 5 m)
 - This length is enough to implement a star topology (the hub is the central node) with 100m radius (i.e. 200m diameter)

Maximum LAN extension

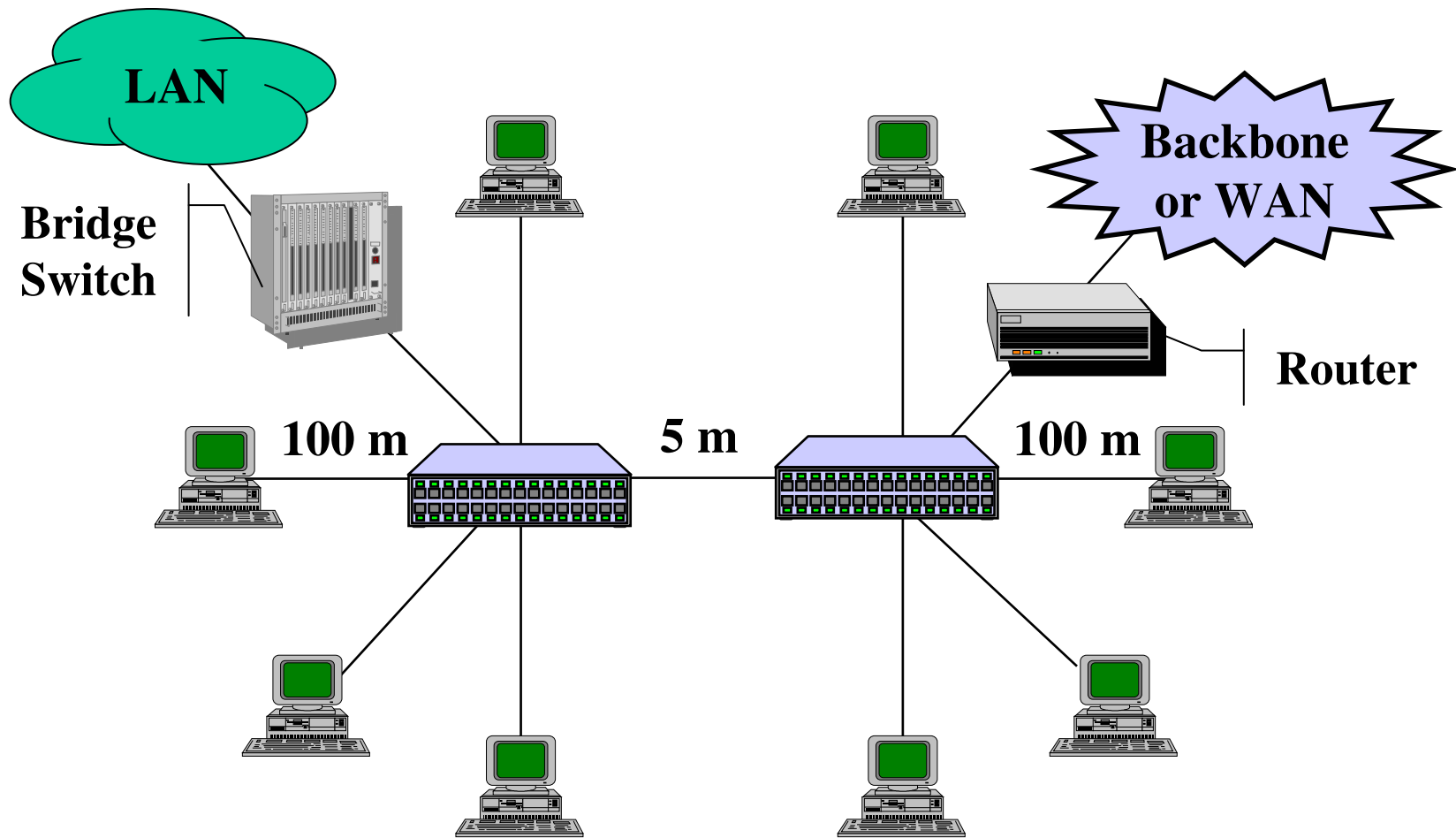

← Collision domain (max 205 m) →

Physical Layer

Point-to-Point connections between:

- stations
- bridge
- switch
- station & repeater

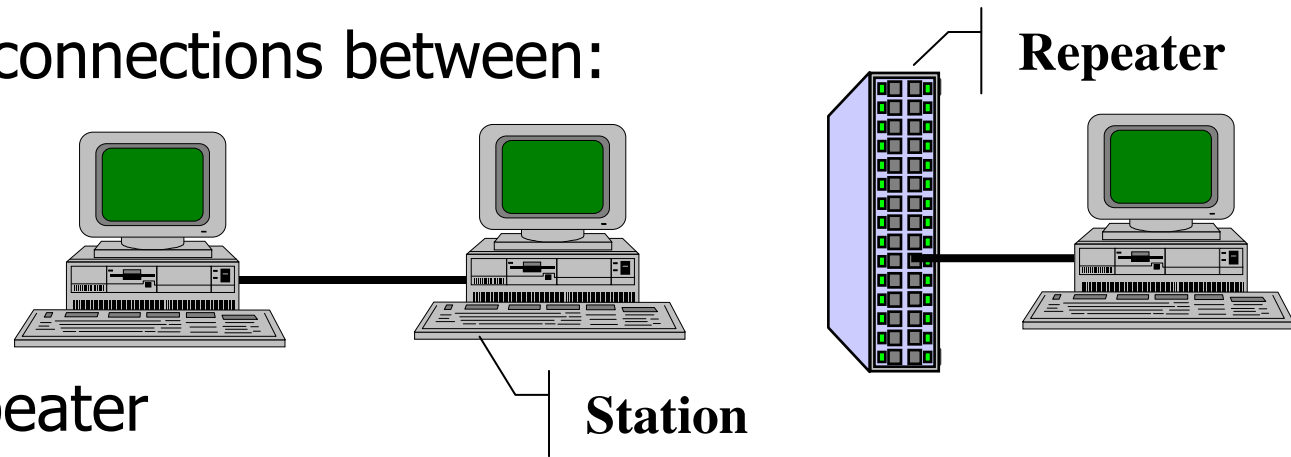

Standard	Media type	use	Max length	Code
100BASE-T4	UTP or STP cat 3 or superior	4 pair	100 m	8B6T
100BASE-T2	UTP or STP cat 3 or superior	2 pair	100 m	PAM5x5
100BASE-TX	UTP or STP cat 5 or superior	2 pair	100 m	FDDI: 4B5B
100BASE-FX	multimode fiber optic (62.5/125 μm)	2 fiber	400 m – HD 2000 m - FD	FDDI: 4B5B

100BASE-T4

4 pairs used

- Half duplex transmission
- 1 for TX
- 1 for RX
- 2 for TX or RX

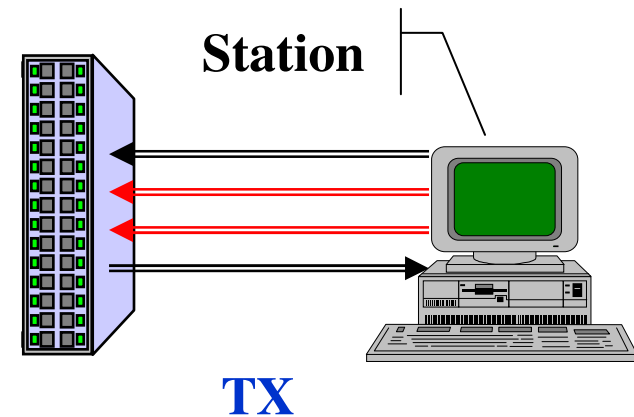
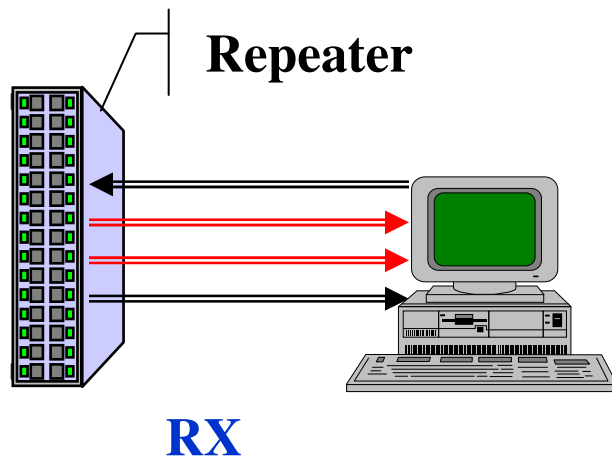

100BASE-T4

Line coding 8B6T

- 8 binary symbols (8B) encoded in 6 ternary symbols (6T)
 - Redundancy used for control symbols
 - DC balance
- Smaller spectral occupancy with same level bit rate
 - 25 MHz → Cat 3 UTP is enough for 100 m

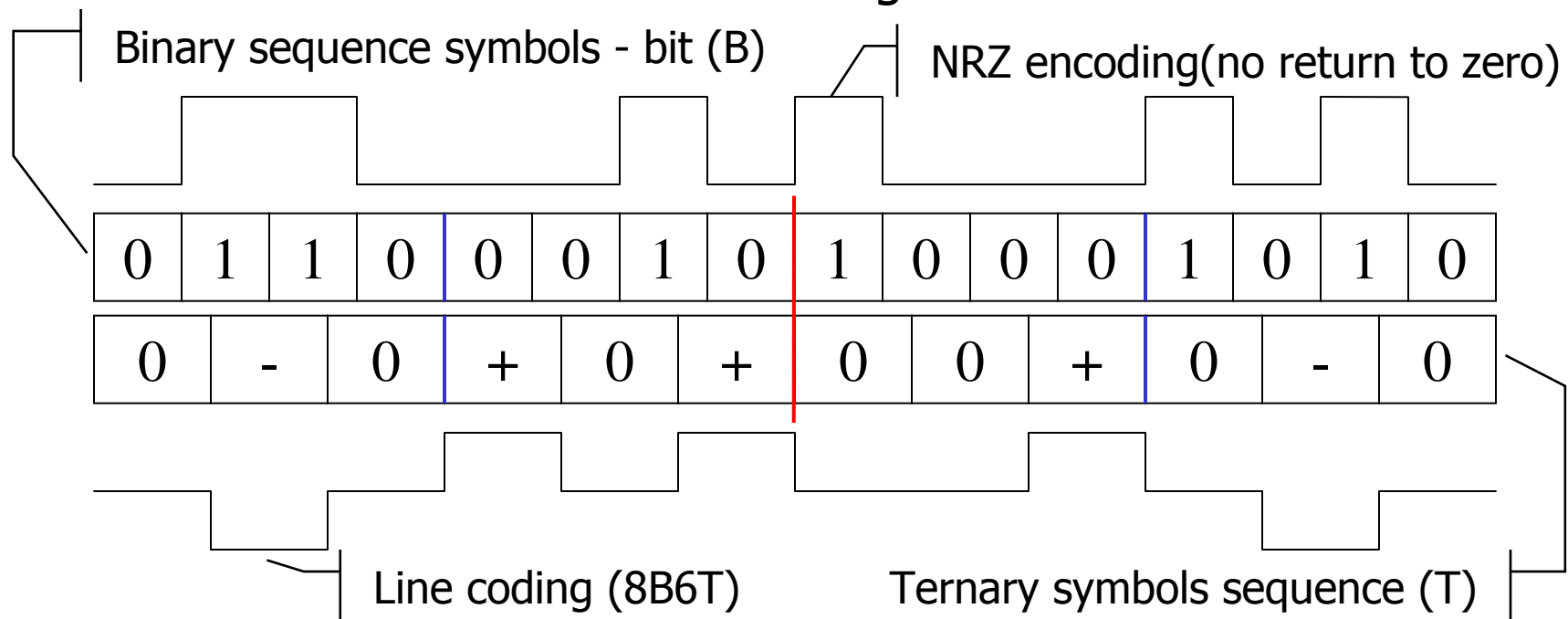

100BASE-T2

2 pairs used

- Full duplex transmission
- Hybrid transformer
- 5-level pulse amplitude modulation PAM 5x5

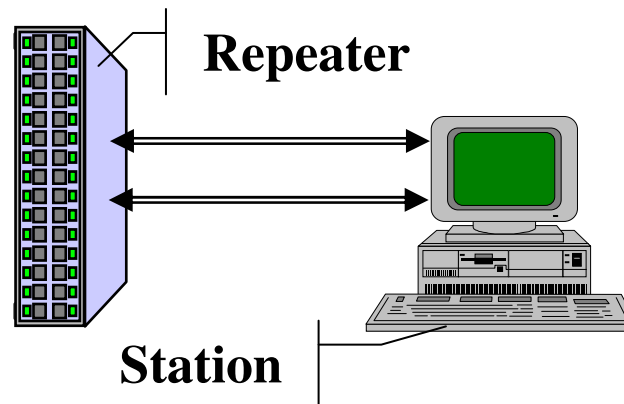

100BASE-T2

Line coding PAM 5x5

- 5-level pulse amplitude modulation
- Binary symbols sequences (bit) encoded in quinary symbols pairs(X,Y)
- Each symbol is transmitted over the two wire pairs
- Quinary symbols pairs are chosen from the constellation in figure
- Redundancy is used to
 - Define control symbols
 - Reduce interference between pairs

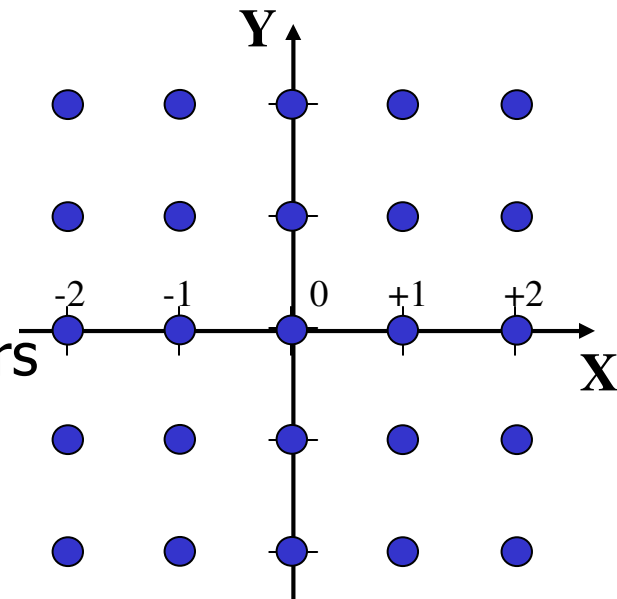

100BASE-X

- Transmission half and full duplex
- 100BASE-X derived from FDDI physical layer specifications (ISO/IEC 9314)
 - 100BASE-TX for copper and 100BASE-FX for fiber
- 100BASE-TX for UTP o STP cables (Shielded Twisted Pair)
 - Maximum segment length: 100 m
 - Maximum LAN diameter 205 m with 2 repeater
- 100BASE-FX for fiber optic cable
 - Maximum segment length (station-to-station): 400 m
 - Limit of CSMA/CD
 - Maximum LAN diameter with 1 repeater 300 m

100BASE-X

Line coding 4B5B

- 4-bit symbols encoded in 5-bit symbols
 - Synchronous transmission at 125 Mb/s
 - Codes guarantee transitions → synchronization
 - Redundancy used for control symbols
 - IDLE code act as Inter-Frame Gap

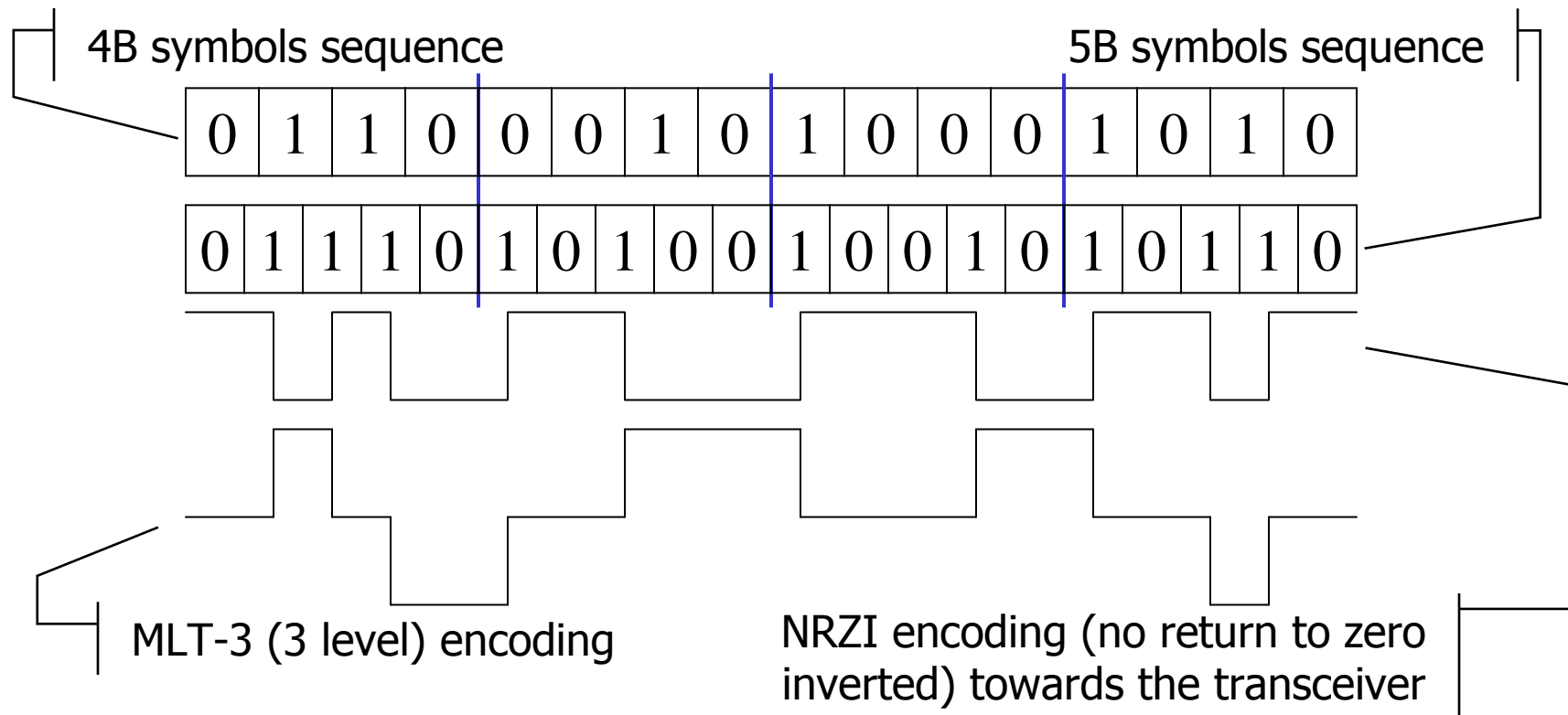

Auto negotiation

- Auto negotiation possibilities:
 - speed (only over copper)
 - half/full duplex (over copper and fiber optic)
- Negotiation sequence:
 - 1 Gb/s full-duplex
 - 1 Gb/s half-duplex
 - 100 Mb/s full-duplex
 - 100 Mb/s half-duplex
 - 10 Mb/s full-duplex
 - 10 Mb/s half-duplex

Gigabit Ethernet

IEEE 802.3z e IEEE 802.3ab

- Protocol extension for collision detection (MAC)
- GMII (Gigabit Media Independent Interface) between Physical and MAC Layers

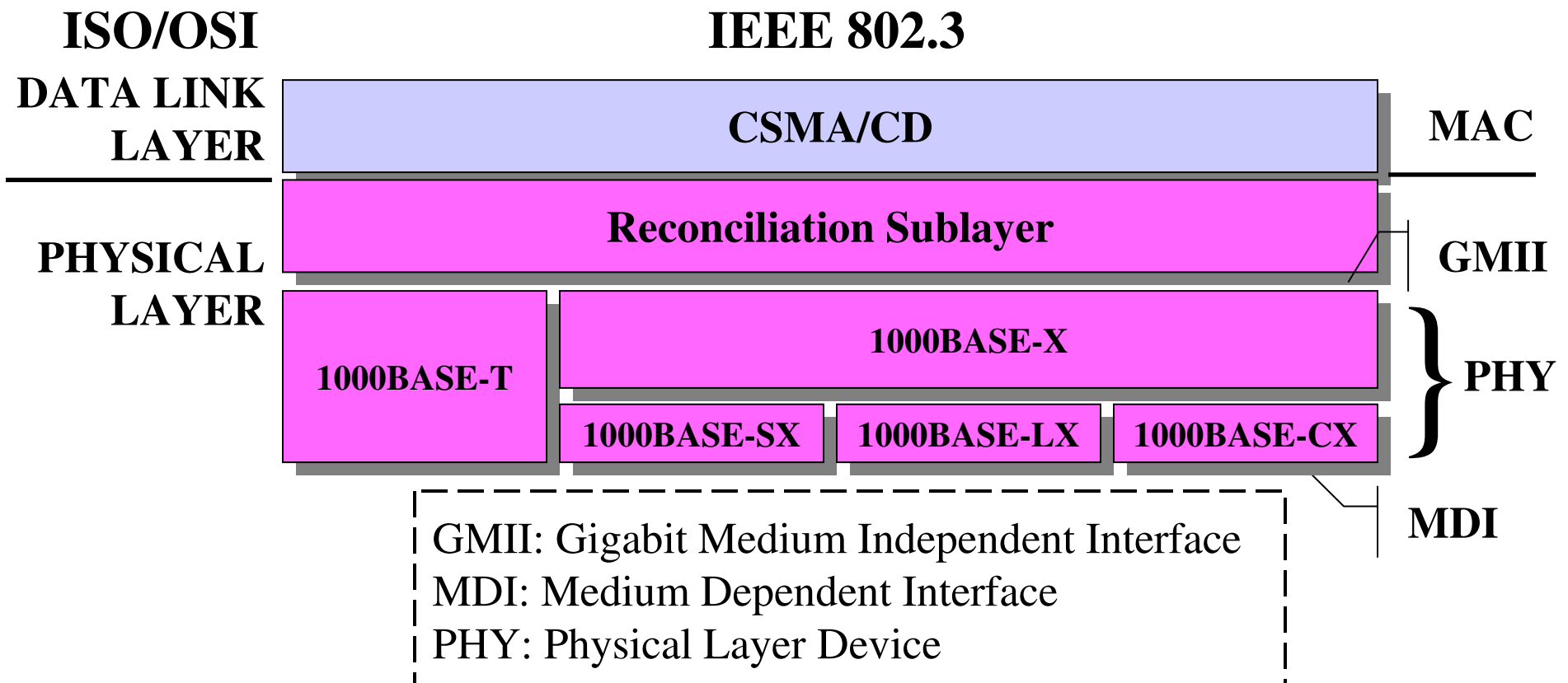

New functionalities

■ *Carrier extension*

- Increase the dimension of frames shortest than 4096 bit
- data + *extension bit* = 4096 bit
- Collision Window = 4.1 μ s
 - Same order of magnitude as Fast Ethernet (5.1 μ s)

■ *Burst mode*

- Station does not give up the medium until packet transmission is over
- Fill bit transmission instead of Inter Frame Gap between frames during burst window
- Continuous transmission up to 77 Kbit (65 K + 12 K)

Carrier Extension

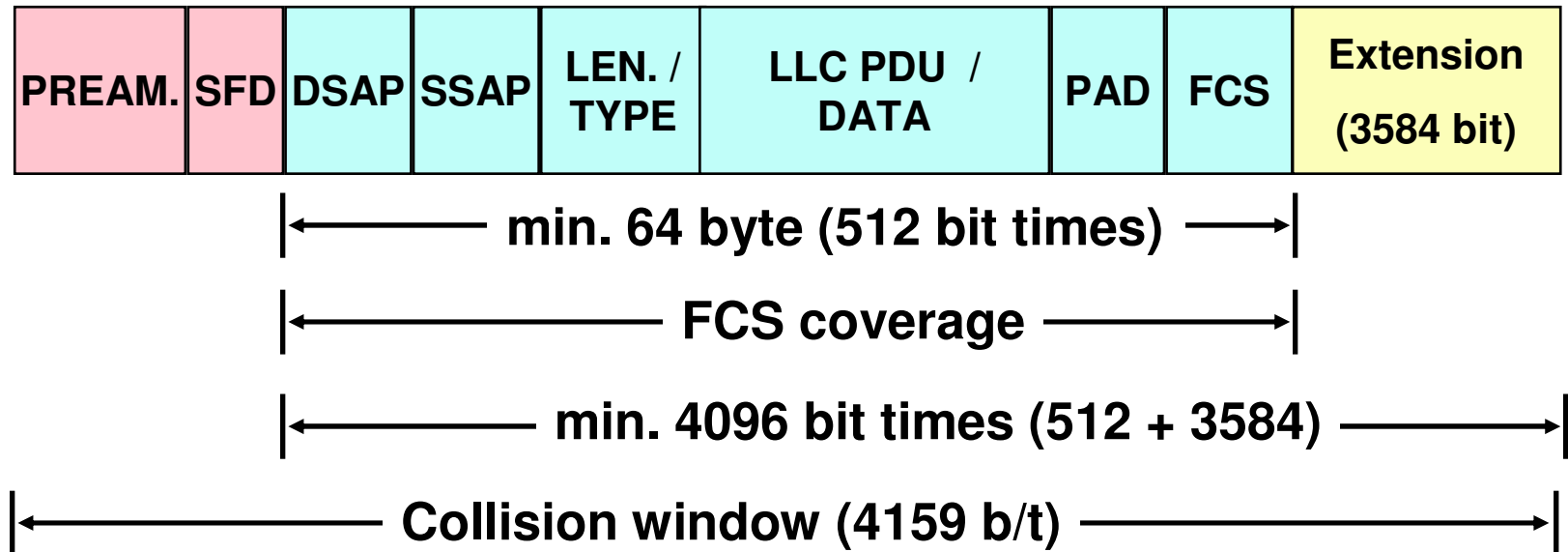

Frame Bursting

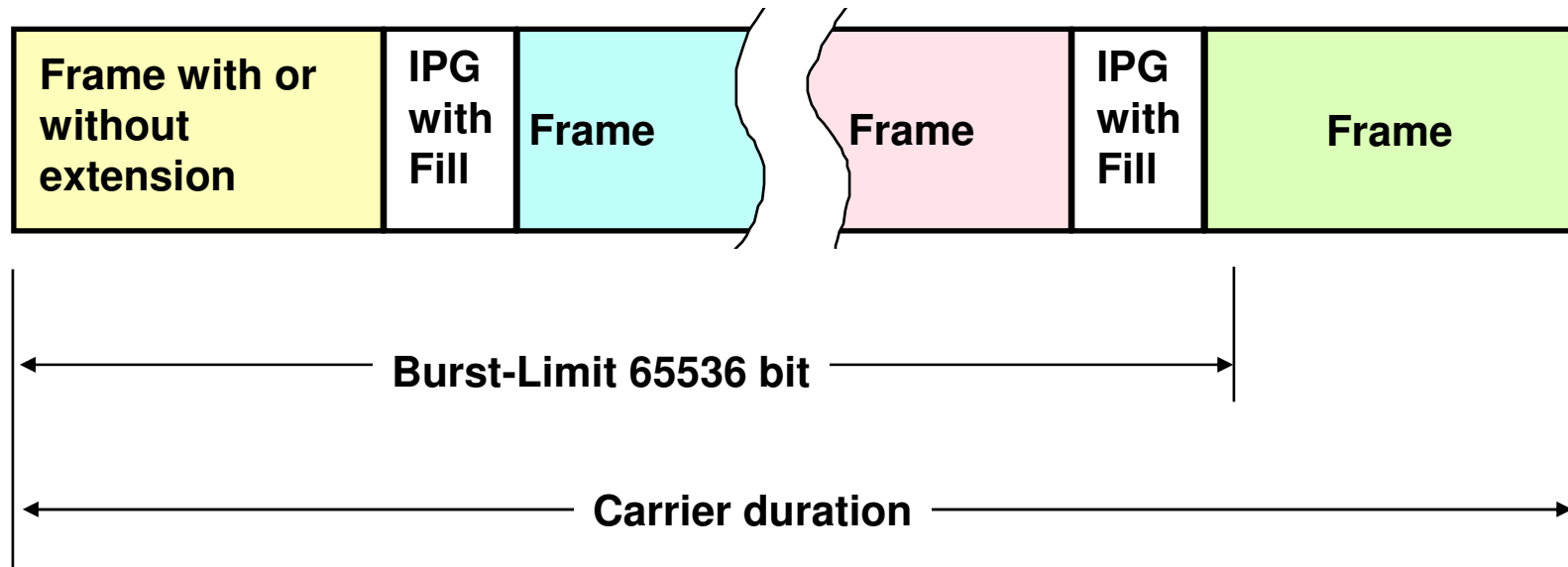

Working modes

- Shared mode to be used with repeaters
 - Not used
 - Not implemented by any commercial products
- Usually used in full duplex mode
 - No carrier extension
 - Collisions does not exist
 - No burst mode
 - Contention does not exist

Gigabit Ethernet Physical layer



MMF = Multi Mode Fiber
SMF = Single Mode Fiber

Standard	Media	Use	Max leng.	Code
1000BASE-SX	MMF 50/125 μm (400 MHz * Km a 850nm)	2 fibers	500 m	FC: 8B10B
	MMF 50/125 μm (500 MHz * Km a 850nm)		550 m	
	MMF 62.5/125 μm (160 MHz * Km a 850nm)		220 m	
	MMF 62.5/125 μm (200 MHz * Km a 850nm)		275 m	
1000BASE-LX	MMF 50/125 μm (400/500 MHz * Km a 1300nm)	2 fibers	550 m	FC: 8B10B
	MMF 62.5/125 μm (500 MHz * Km a 1300nm)		550 m	
	SMF 10/125 μm		5000 m	
1000BASE-CX	STP (jumper cable) 150 Ω	2 pairs	25 m	FC: 8B10B
1000BASE-T	UTP balanced 100 Ω Cat. 5E	4 pairs	100 m	PAM5

1000BASE-T (IEEE 802.3ab)

- Full-duplex transmission over 4 pairs
 - 250 Mb/s per pair
 - Hybrid transformers
- PAM5 Line coding (5-level Pulse Amplitude Modulation)
 - 6 binary symbols encoded in quinary symbol quadruple
 - Each symbol transmitted over a pair
 - 125 Mbaud per pair
 - Redundancy used for control codes
- Cat 5 UTP has to pass further test in addition to those provided by TIA/EIA TSB95 standard on structured wiring

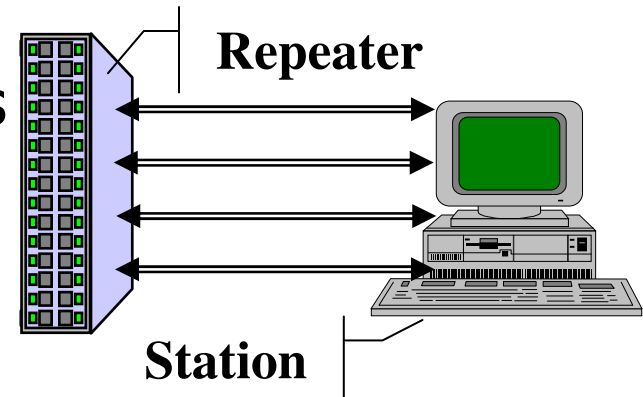

1000BASE-X

- Sub Standard
 - 1000BASE-CX (copper short range)
 - 1000BASE-SX (short wavelength)
 - 1000BASE-LX (long wavelength)
- Based on Fiber Channel (FC) Physical Layer
 - Code 8B10B
 - Redundancy code: control symbol and transitions

1000BASE-CX connectors

Type 1 connector

1: Transmission +
6: Transmission -

Shell: shield

5: Reception -
9: Reception +

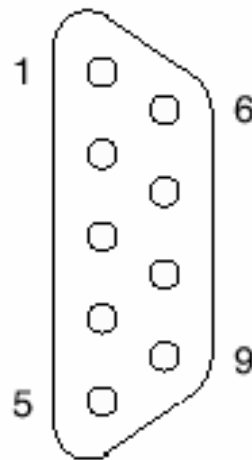

Type 2 connector

1: Transmission +
3: Transmission -

6: Reception -
7: Reception +

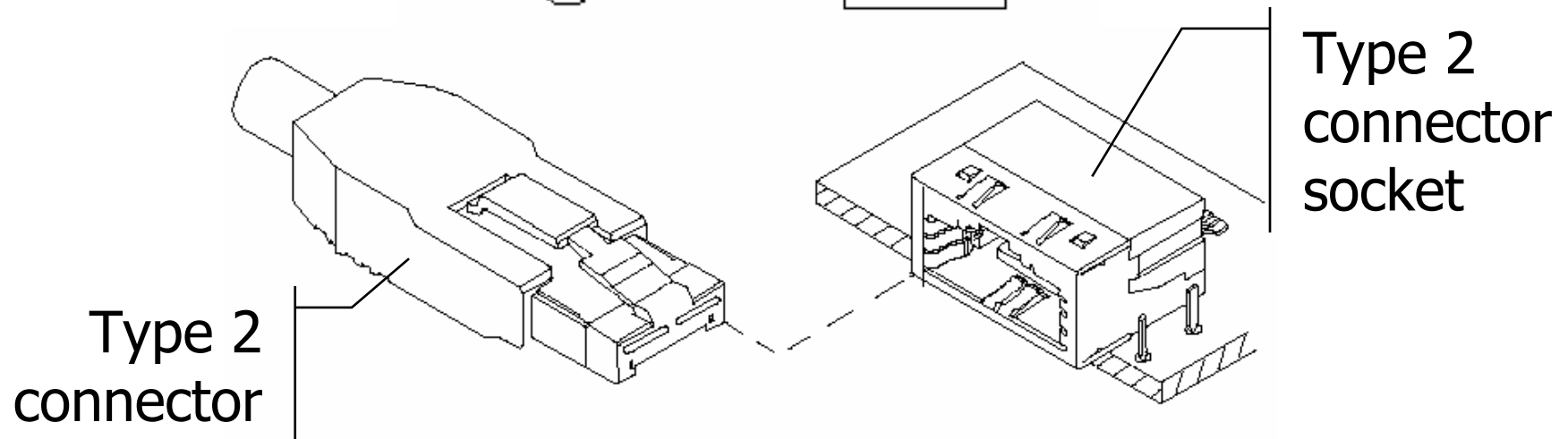
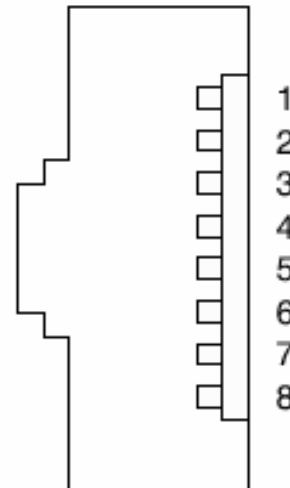

1000BASE-SX e 1000BASE-LX connectors

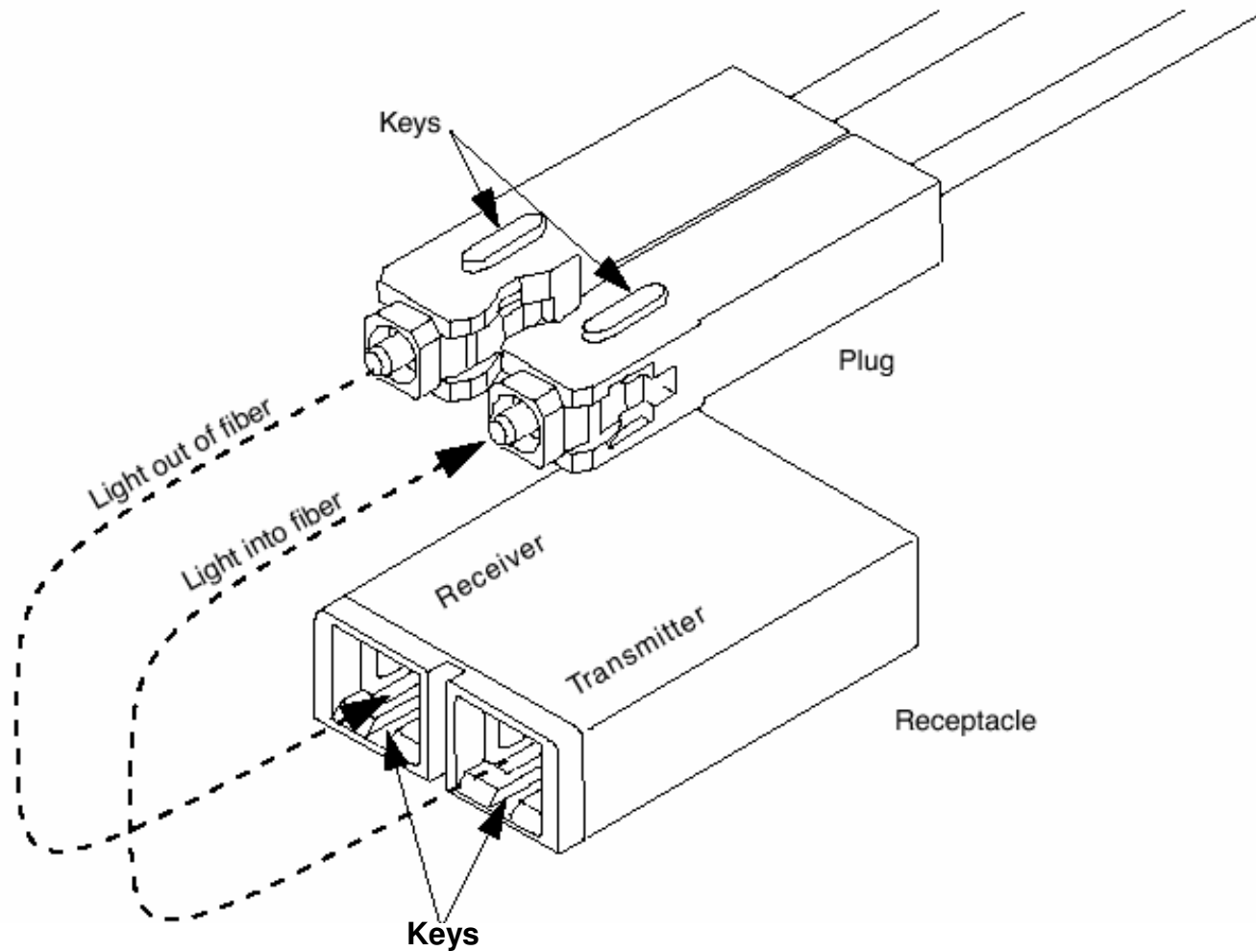

Wave-Length and standard

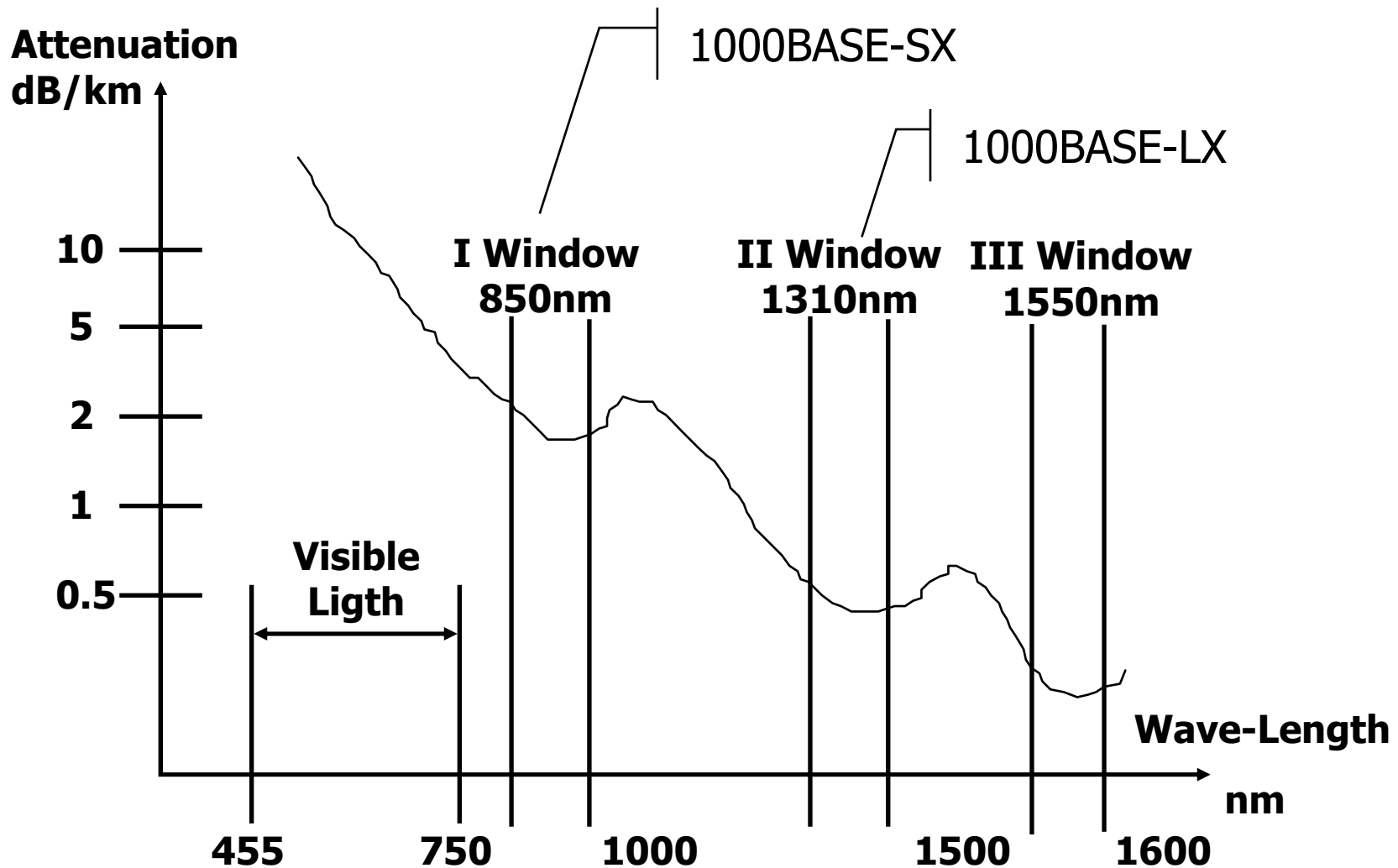

1000BASE-LX & multimode fiber: Mode Conditioning Patch Cord

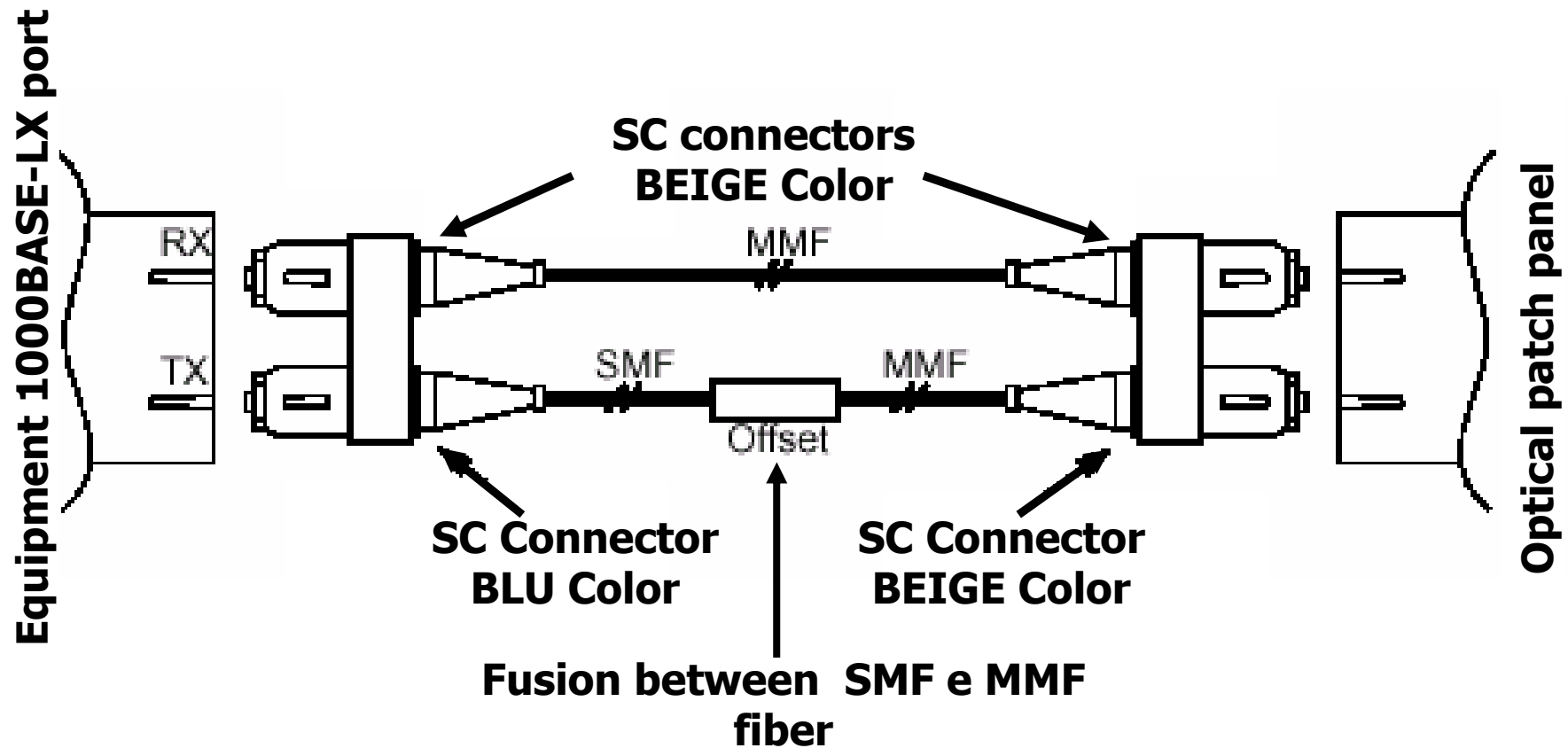

MMF = Multi Mode Fiber
SMF = Single Mode Fiber

Non standard products

- 1310 nm single-mode fiber: 10 Km
 - Example Cisco GBIC 1000BASE-LX/LH
- 1550 nm single-mode fiber dispersion shift: 100 Km
 - Example Cisco GBIC 1000BASE-LZ
- Interoperability between products of different vendors is not guaranteed

10 Gigabit Ethernet - IEEE 802.3ae

- IEEE 802.3 frame
- Full-duplex mode
 - No repeater
 - No CSMA/CD
 - No carrier extension
- Keep Ethernet's good reputation
 - 10 times more efficient
 - 3 times more expensive
- Break into metropolitan network (MAN) and wide area network (WAN) markets
 - Price/Bandwidth ratio is higher than traditional solutions (SONET/SDH, Frame Relay, ATM)

Architectural model

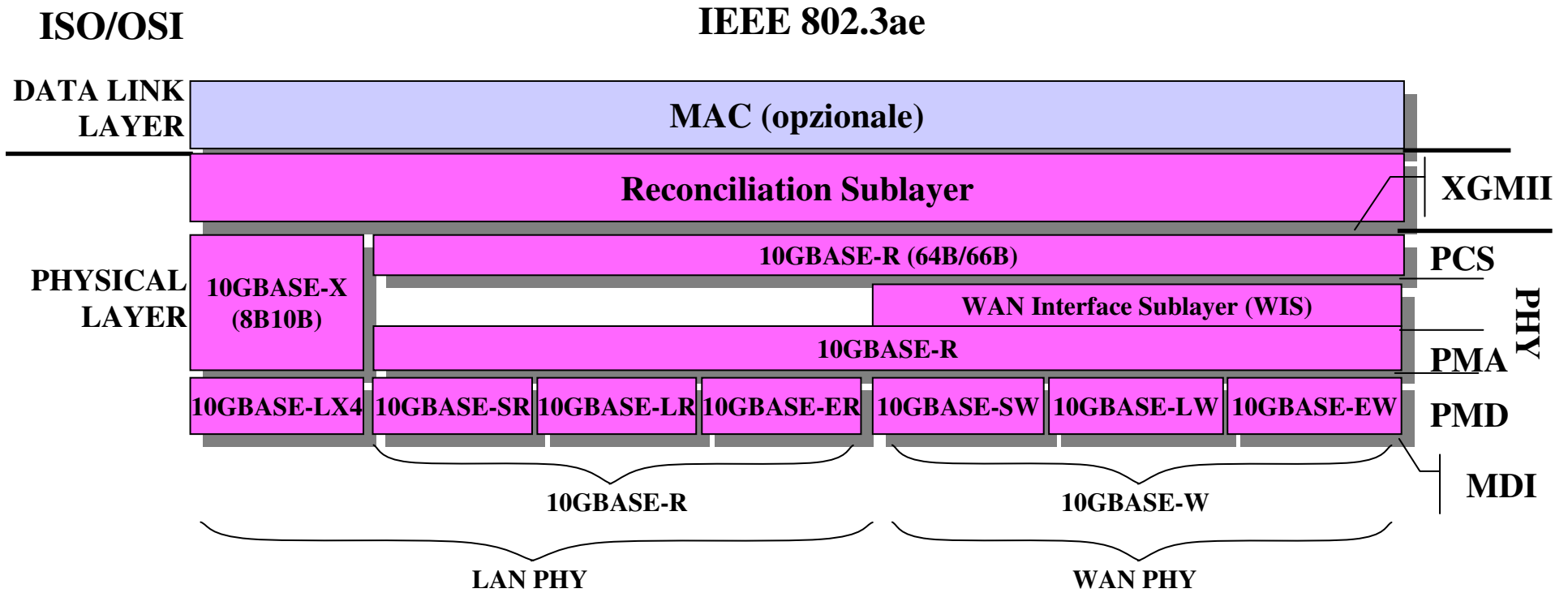

MDI: Medium Dependent Interface PMA: Physical Medium Attachment
 PCS: Physical Coding Sublayer PMD: Physical Medium Dependent
 PHY: Physical Layer Device XGII: 10 Gigabit Medium Independent Interface

WAN PHY

- Enables transport over existent MAN and WAN infrastructure
 - DWDM (Dense Wavelength Division Multiplexing)
- Enables existent MAN and WAN component reuse
 - SONET/SDH transceiver and circuitry
- Different transmission speed (9.6 Gb/s) respect to LAN PHY's speed
- WAN PHY and LAN PHY common properties→ market is waiting for components with both functionalities
 - 10GBASE-R and 10GBASE-W in particular
- WIS (WAN Interface Sublayer) tunes PCS' signal
 - Bit scrambling
 - SONET/SDH headers

10GE frame over SONET/SDH

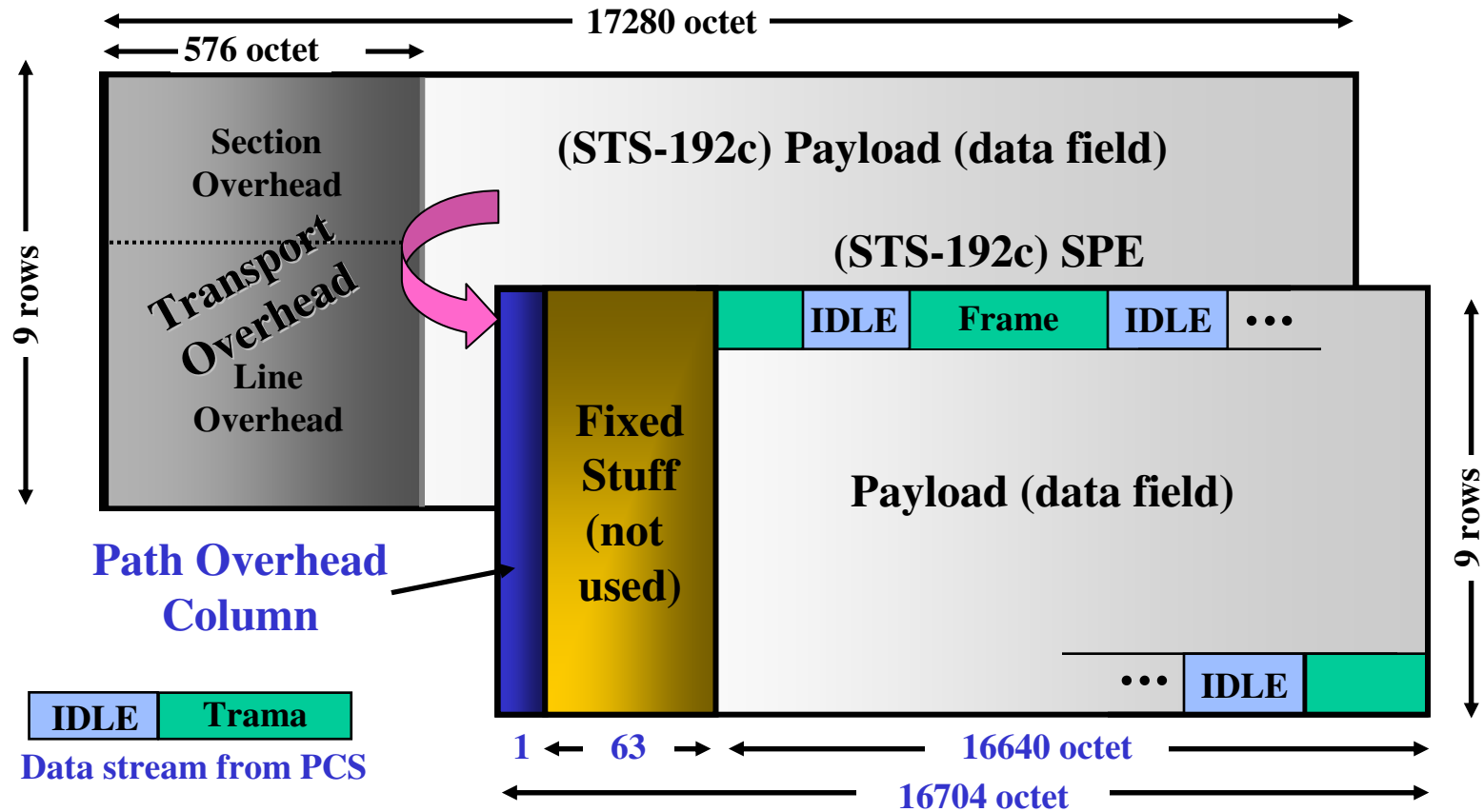

STS-192c = Synchronous Transport Signal – di livello 192, c = concatenated

SPE = Synchronous Payload Envelope

10GE and SONET/SDH

- Simplified version of SONET/SDH
 - Avoid imposed complexities required by SONET/SDH
 - Limit component cost
- Only some header's fields are used
- High precision synchronization has been removed
 - No Stratum-1 clock (10^{-12} precision)
- Frames are generated and forwarded by 10GE devices in asynchronous mode using
 - SONET/SDH framing
 - Limited SONET/SDH management functionalities

Physical layer

Standard	Fiber	Max lenght	Window	Usage	Coding
10GBASE-SR	Multimode 62.5 μm	26 – 33 m	850 nm	Building (orizontal wiring)	64B/66B
	Multimode 50 μm	66 – 300 m			
10GBASE-LR	Monomode (10 μm)	10 Km	1310 nm	Area	64B/66B
10GBASE-ER	Monomode (10 μm)	40 Km	1550 nm	Metropolitan	64B/66B
10GBASE-LX4	Multimode 62.5 μm	300 m	1310 nm	Building (orizontal wiring)	FC 10G: 8B10B
	Multimode 50 μm	240 – 300 m			
	Monomode (10 μm)	10 Km		Area	
10GBASE-SW	Multimode 62.5 μm	26 – 33 m	850 nm	Building (orizontal wiring)	64B/66B SONET/SDH framing
	Multimode 50 μm	66 – 300 m			
10GBASE-LW	Monomode (10 μm)	10 Km	1310 nm	Area	64B/66B SONET/SDH framing
10GBASE-EW	Monomode (10 μm)	40 Km	1550 nm	Metropolitan	64B/66B SONET/SDH framing

10GBASE-X

- Coding derived from 10G FC (Fiber Channel at 10 Gb/s)
- 32 bit blocks are encoded in 4 blocks of 10 bit each
- Sent over 4 lane
 - 3.125 Gbaud per lane
- Redundancy used for control codes
 - For example idle signal act as inter-frame gap

10GBASE-LX4

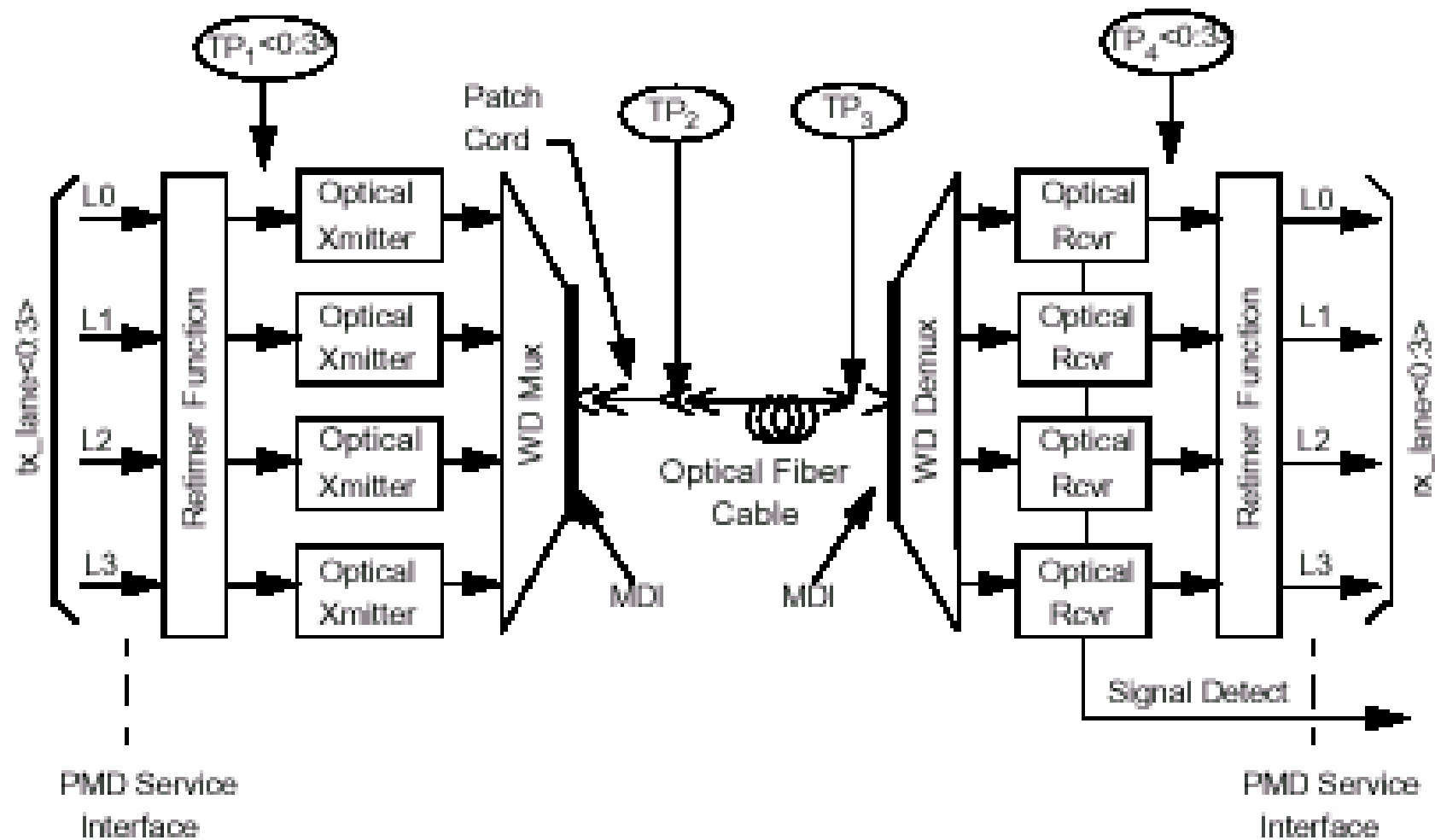

WD = Wavelength Division