



IEEE 802.3 - ISO 8802.3 CSMA/CD

Pietro Nicoletti
www.studioreti.it



Copyright note

- These slides are protected by copyright and international treaties. The title and the copyrights concerning the slides (inclusive, but not only, every image, photograph, animation, video, audio, music and text) are the author's (see Page 1) property.
- The slides can be copied and used by research institutes, schools and universities affiliated to the Ministry of Public Instruction and the Ministry of University and Scientific Research and Technology, for institutional purpose, not for profit. In this case there is not requested any authorization.
- Any other complete or partial use or reproduction (inclusive, but not only, reproduction on discs, networks and printers) is forbidden without written authorization of the author in advance.
- The information contained in these slides are believed correct at the moment of publication. They are supplied only for didactic purpose and not to be used for installation-projects, products, networks etc. However, there might be changes without notice. The authors are not responsible for the content of the slides.
- In any case there can not be declared conformity with the information contained in these slides.
- In any case this note of copyright may never be removed and must be written also in case of partial use.



IEEE 802.3

- Evolution of Ethernet LAN realized by Digital, Intel and Xerox in the 1982
 - The first 802.3 standard version as been approved in the 1985
- Physical layer:
 - bus topology coax based
 - star topology UTP & Fiber optic based
 - transmission speed 10 Mb/s
- Mac sub-layer:
 - CSMA/CD (Carrier Sense – Multiple Access – Collision Detection)



Layers

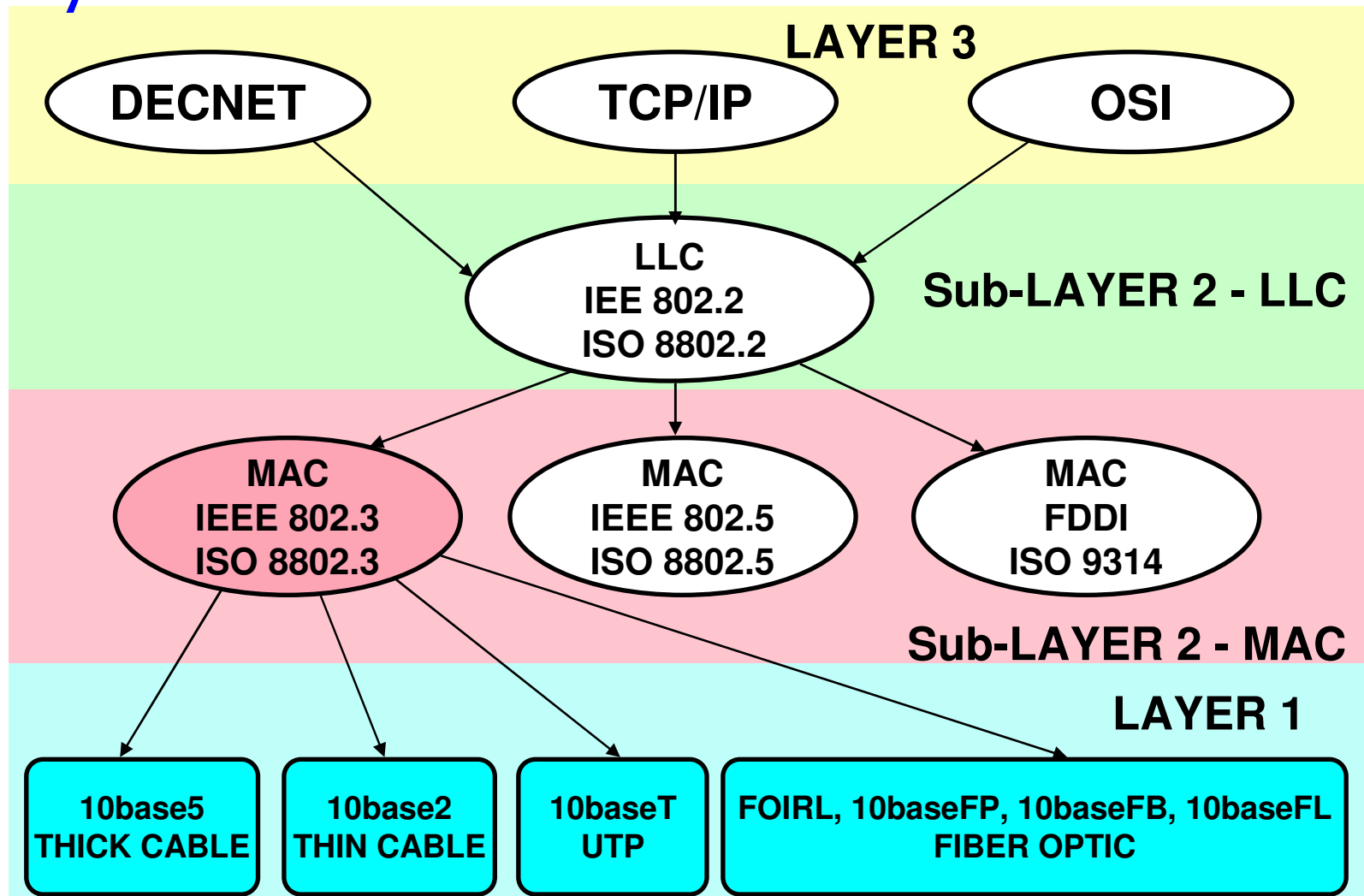



Frame format

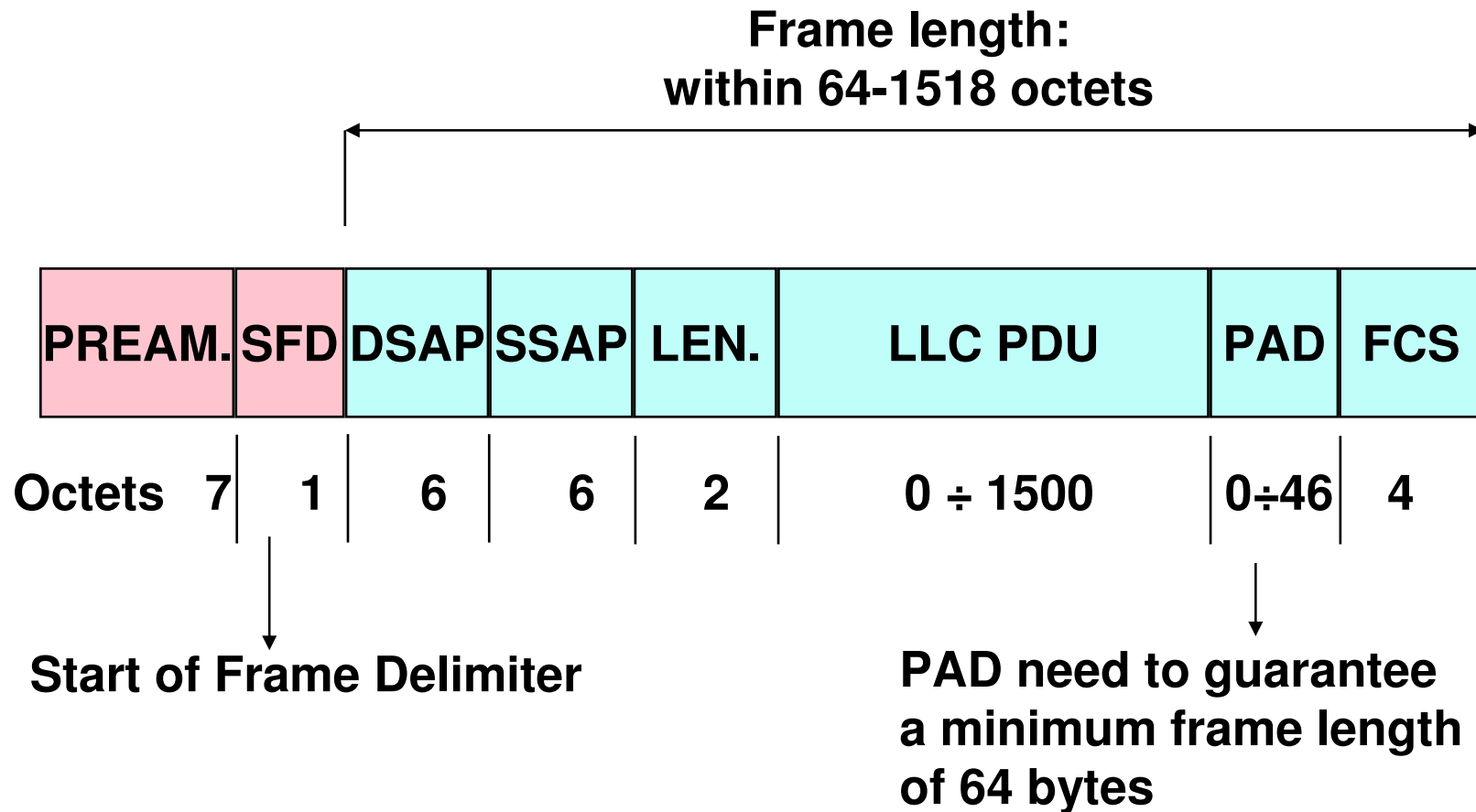



Ethernet v2.0 & IEEE 802.3

**NETWORK
LAYER**

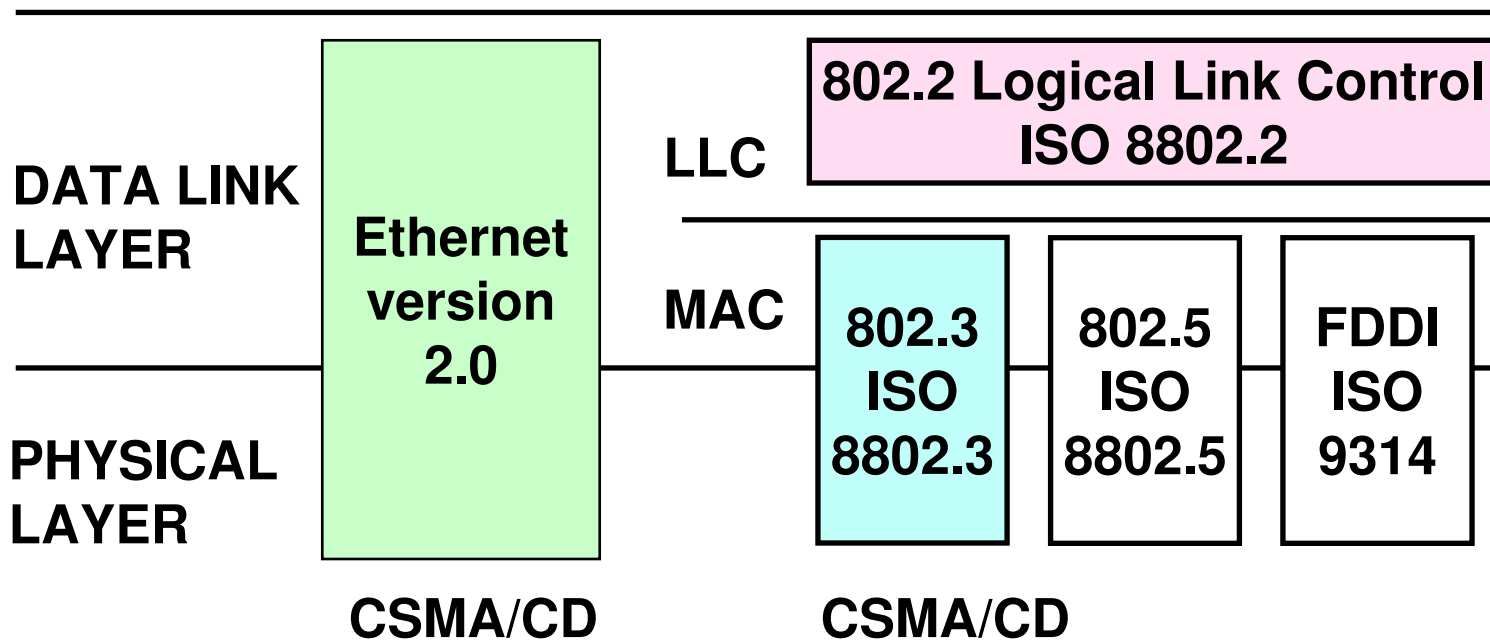

**Ethernet v2.0 by:
Digital, Intel, Xerox**

Standard: ANSI/IEEE & ISO/IEC



Ethernet - IEEE 802.3 Compatibility

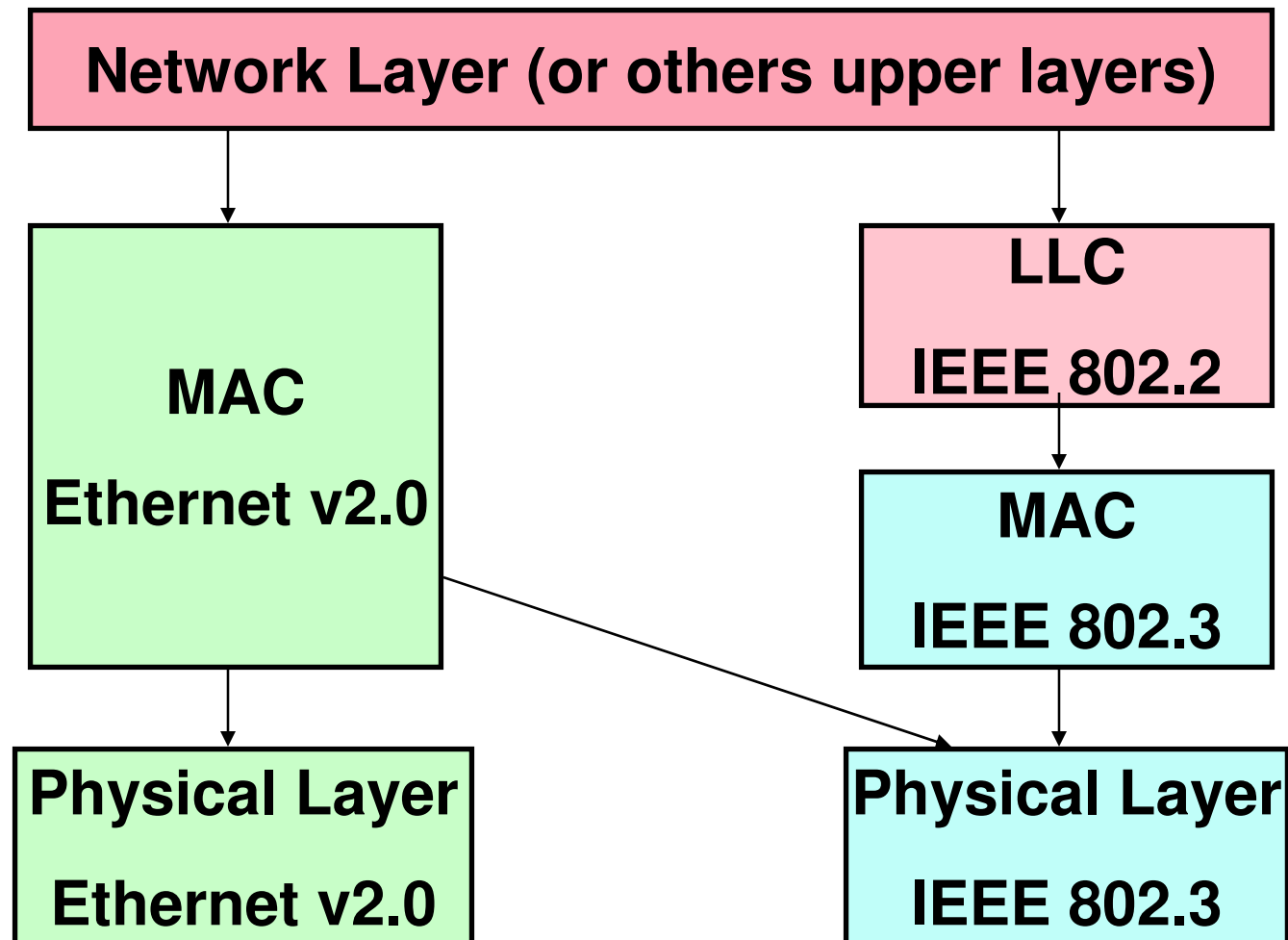



Ethernet - IEEE 802.3 Compatibility

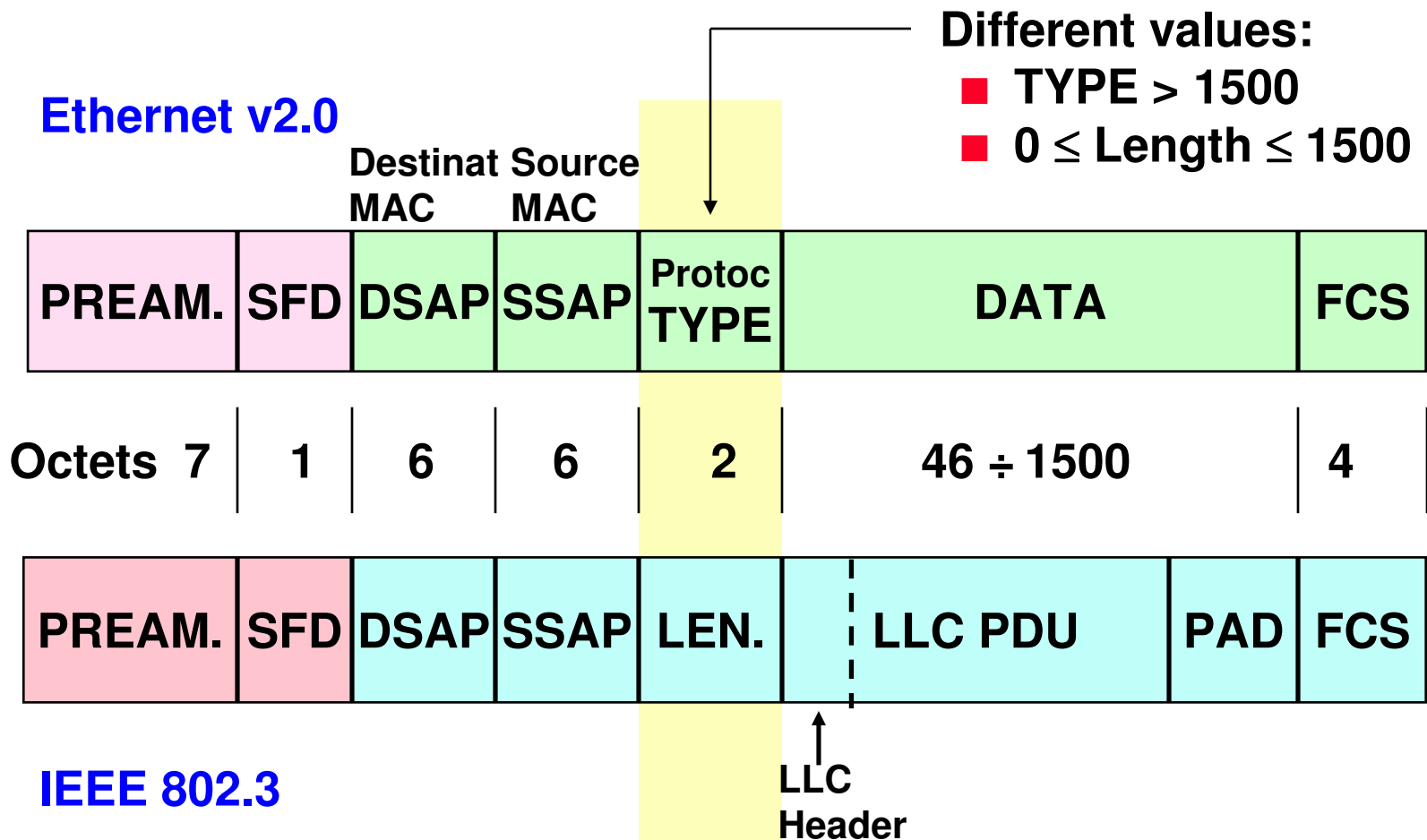



Physical Layer standards

- IEEE 802.3 specify 7 physical layer standards:
 - 10BASE5: thick coax based
 - 10BASE2: thin coax based
 - 10BASET: UTP based
 - FOIRL: fiber optic based, used to interconnect repeaters
 - 10BASEFL: fiber optic based, used to connect repeaters and stations
 - 10BASEFB: fiber optic based, ideal for fault tolerant applications
 - 10BASEFP: fiber optic based using passive optical star coupler



Transmitting Station

- Listen before talking
- Listen while talking to detect a collision
- If detect collision:
 - Stop transmission
 - Start a timer to retransmit
 - Timer based on backoff algorithm



10BASE5

- Ethernet v2.0 compatible

- Yellow cable

- Thick cable

- RG213 like

- AUI = Attachment Unit Interface

■ 50 Ω TERMINATOR

■ TRANSCEIVER

□ BARREL CONNECTOR

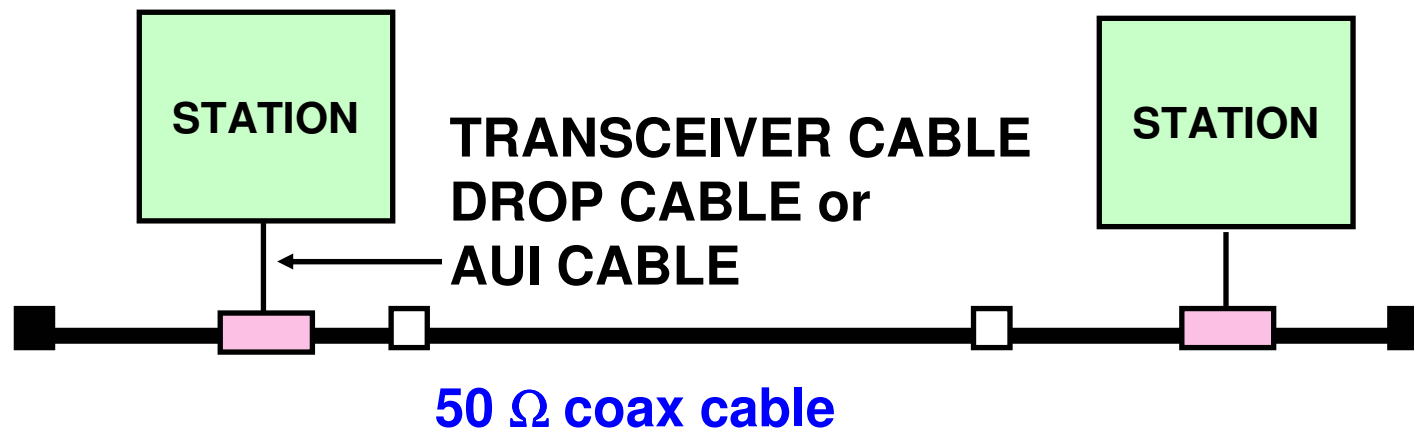



10BASE5

- Segment max. length 500 m
- Cable sections: 23.4 m, 70.2 m, 117 m
- Minimum distance allowed between 2 transceiver: 2.5 m
- Minimum propagation velocity: $0.77 c$
- Maximum transceivers in a segment: 100
- Transceiver cable max. length 50 m



Transceiver hardware connections

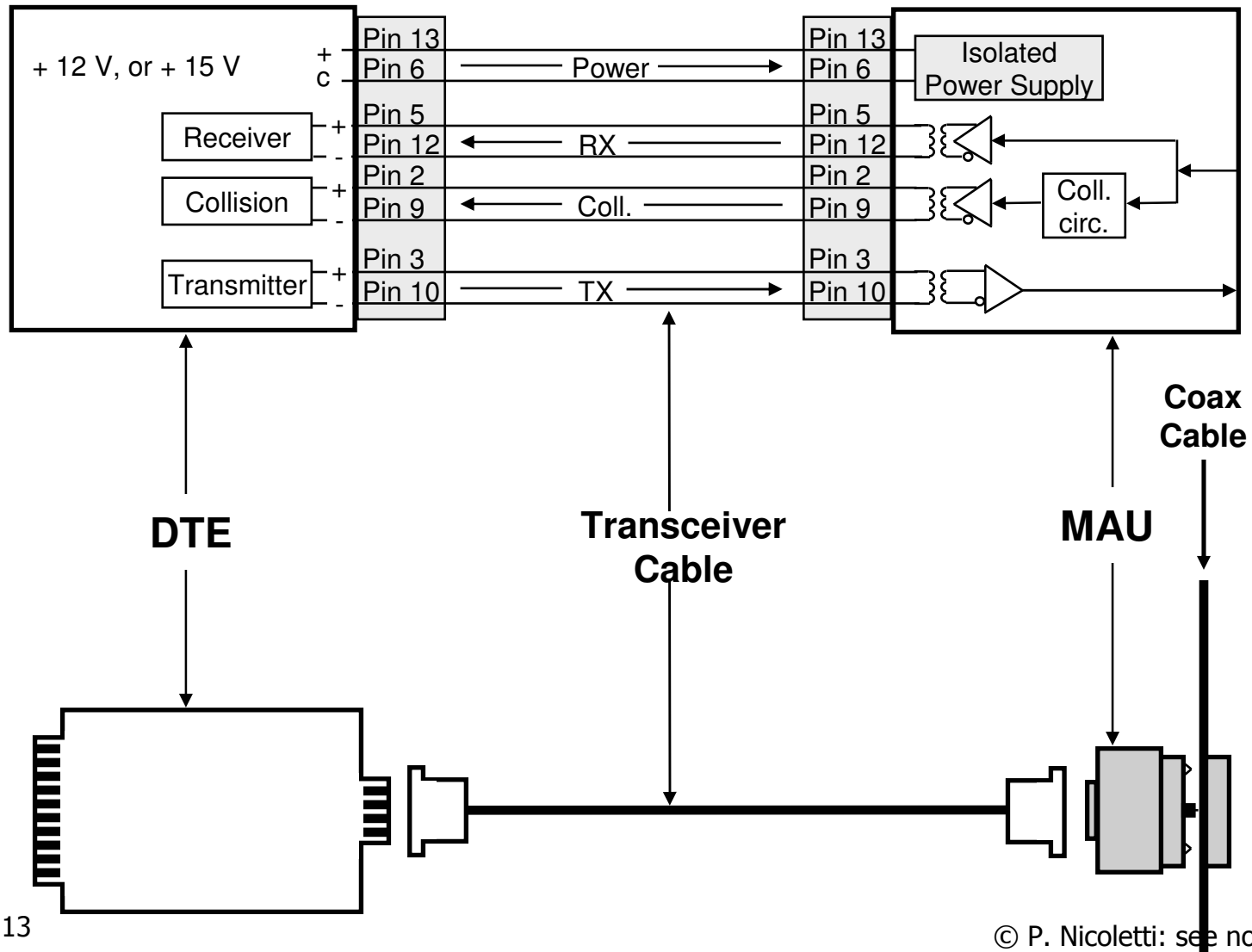



10BASE2

- Thin-Ethernet cable
 - RG58 A/U o RG58 C/U

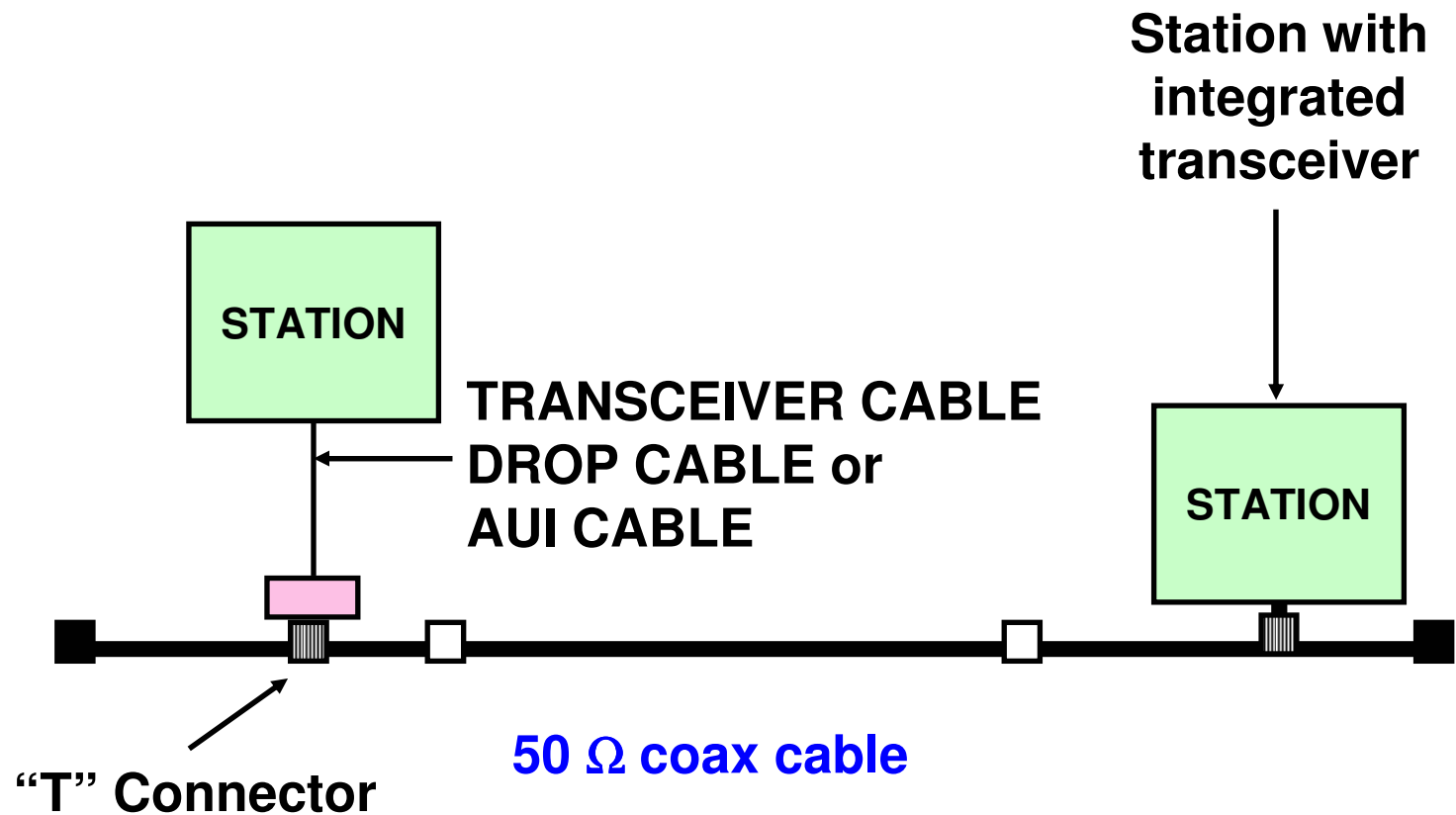



10BASE2

- Segment max. length 185 m
- Minimum distance allowed between 2 transceiver:
0.5 m
- Minimum propagation velocity: $0.65 c$
- Maximum transceivers in a segment: 30
- Transceiver cable max. length 50 m



10BASE-T

- Standard IEEE 802.3 to use UTP cable (Unshielded Twisted Pair)
- Characteristics:
 - best solution for office LAN
 - the UTP cable is:
 - easy to install
 - easy termination on RJ45 plug and jack
- Point to point standard:
 - need repeater to connect stations
 - the connection between stations and repeater need 2 pair UTP cable:
 - TX station - RX repeater
 - RX station - TX repeater



10BASE-T

- Can be used on structured cabling system:
 - ISO/IEC 11801
 - TIA/EIA 568A
- UTP cable 100 Ω
- suggested maximum length 100 m
 - 90 m of cabling system
 - 10 m of patch cords



10BASE-T jack and plug

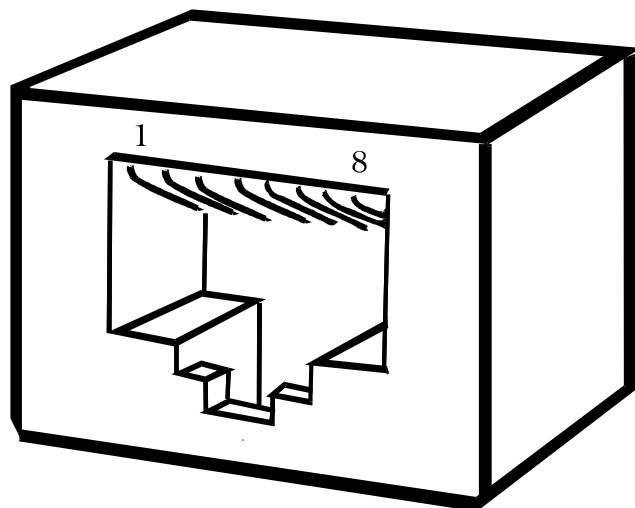

RJ45 jack

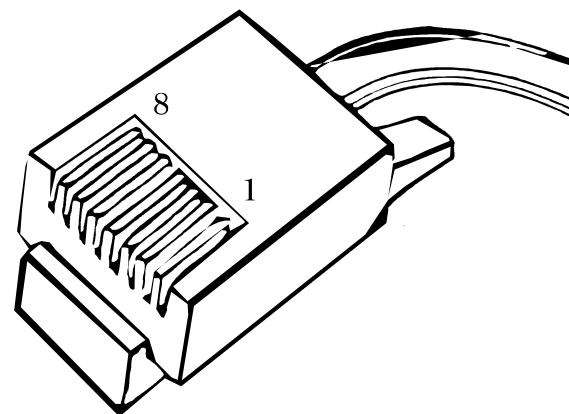

RJ45 plug

RJ45: 8 contacts central key



RJ45: pin assignment

- TD+ (pin 1)
- TD- (pin 2)
- RD+ (pin 3)
- Not used
- Not used
- RD- (pin 6)
- Not used
- Not used

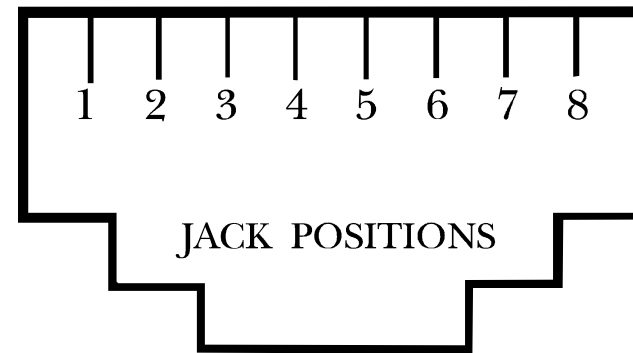

Front view



10BASE-T: Crossover Function

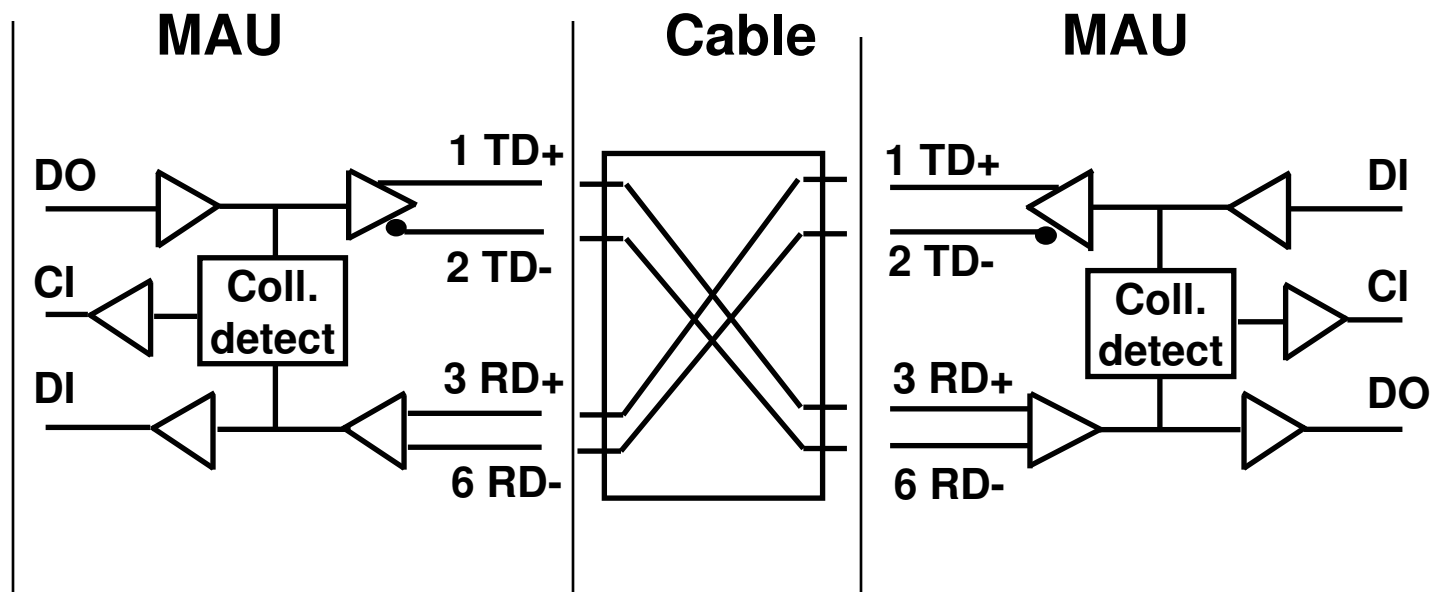

The crossover function can be directly implemented in the MAU

MAU: Medium Attachment Unit (Transceiver)



SQE test

- The MAU (transceiver) at end of frame transmission send a SQE signal to DTE over collision pair:
 - SQE signal is used to test collision circuits
 - this is also know as Heartbeat
- This function is important to guarantee a correct LAN operation:
 - must be disable when the transceiver via AUI is connected to a repeater



SQE timing

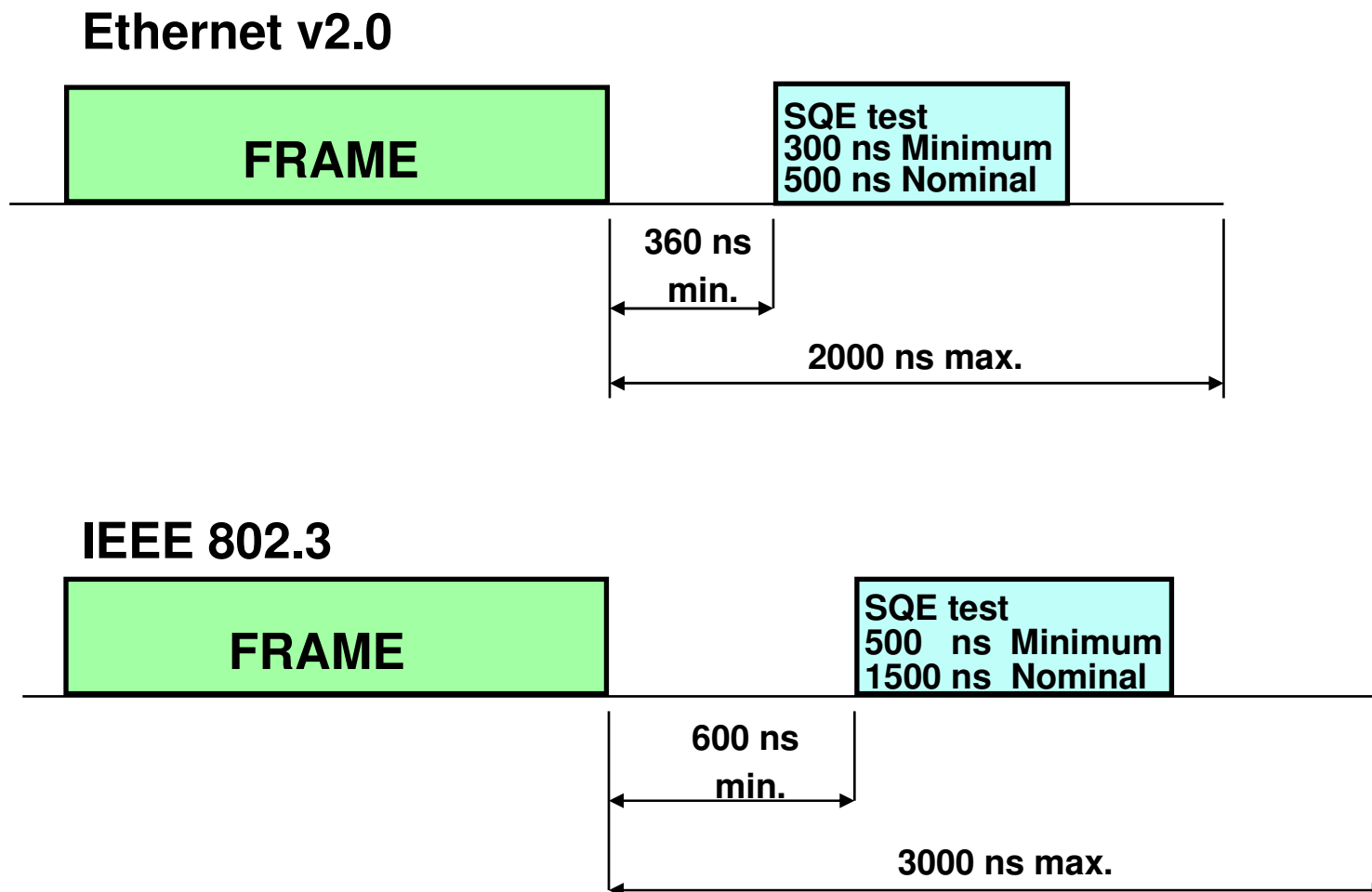



10BASE-FL (Fiber Link)

- Evolution of standard FOIRL (Fiber Optic Inter Repeater Link):
 - FOIRL compatible
 - implement the additional functions of:
 - Link Integrity Test
 - Jabber
 - Maximum link length 2000 m:
 - power budget calculation

1.5 dB	2 ST connectors insertion loss
8 dB	attenuation over 2 Km
1 dB	margin
10.5 dB	power budget



10baseFB (Fiber Backbone)

- Synchronous standard
 - Synchronous-Idle (SIDL) signal used to synchronize permanently TX & RX circuits
- 10baseFL improvements:
 - Remote low light
 - Remote fault
- Maximum link length 2000 m
- Up to 20 repeater cascade
- Standard promoted by Chipcom and Lannet Companies



10baseFP

- Based on Passive Star Coupler
 - Maximum distance between MAU & STAR Coupler :
 - 500 m
- Passive Star Coupler is based on optical signal splitting
 - Produced in the past by Codenoll company



Segment Type

- 2 Segment type:
 - Mixing Segment can connect more than 2 transceiver (point-to-multipoint connection):
 - 10Base5
 - 10Base2
 - 10BaseFP
 - Link Segment can connect only 2 transceiver (point-to-point connection):
 - 10BaseT
 - FOIRL
 - 10BaseFL
 - 10BaseFB



Repeater: normally called HUB

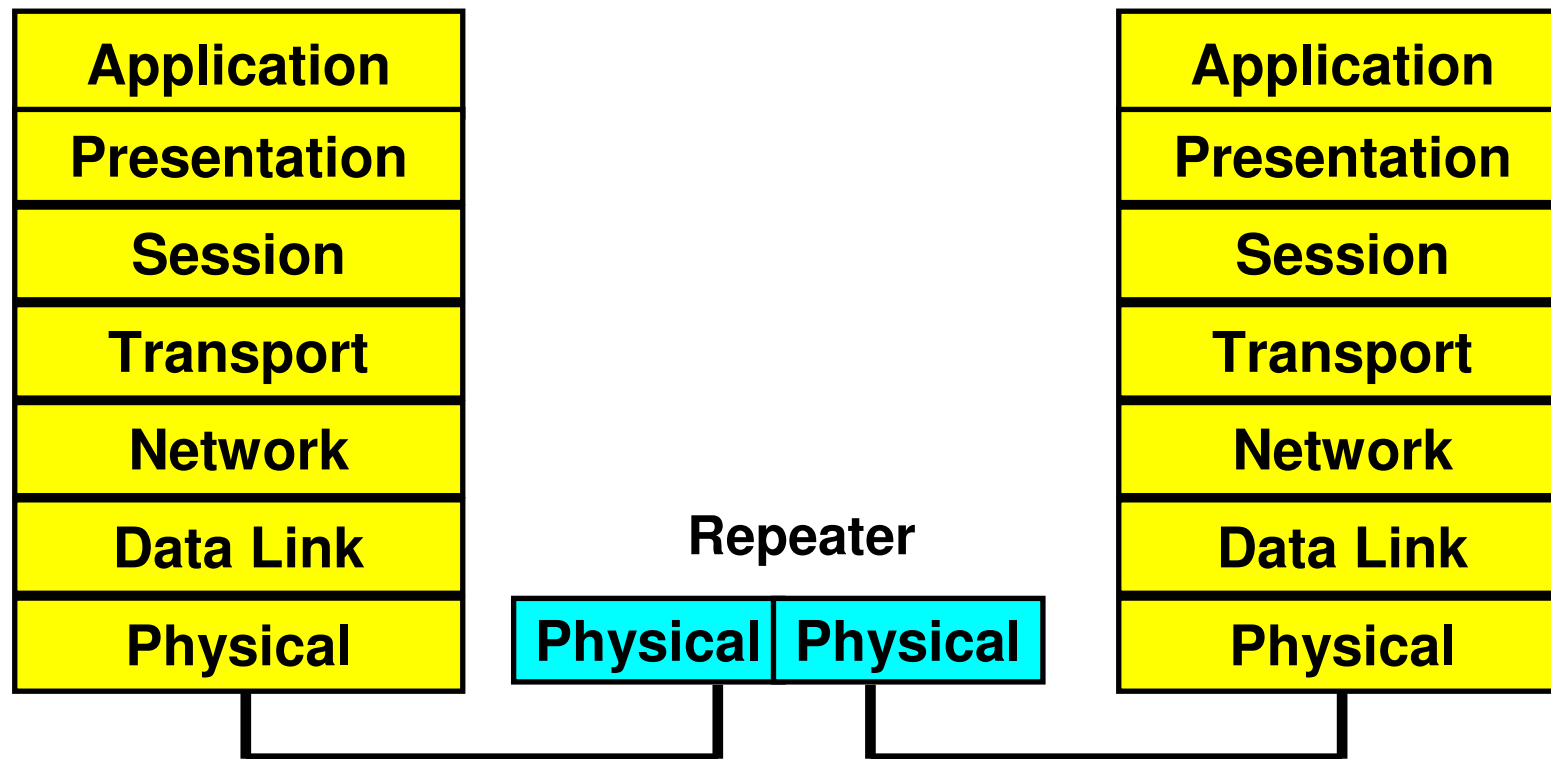



Repeater function

- Signal Amplification
- Signal Symmetry
- Signal Retiming
- Carrier Sense and Data Repeat
- Preamble Insertion
 - May reduce Inter Packet Gap (IPG)
- Fragment Extension (min 96 bit)
- Collision Detection and Jam Generation
- Test functions



Repeater limits

- A repeater IEEE 802.3 introduce a delay of 14 bit-time (1.4 μs)
- Repeater Set
 - Assembly that consider
 - 1 repeater
 - 2 drop cable (50 m)
 - 2 transceiver
 - Repeater set delay 53.28 bit-time (5.33 μs)
 - Delay equivalency 530 m of cable



Maximum LAN extension with 3 coax & F.O. (Ethernet 10 Mb/s)

- Max diameter 3000 m:
 - 3 coax segment of 500 m each
 - 2 FOIRL or 10BaseFL segment of 500 m each
 - 10 drop cable of 50 m each

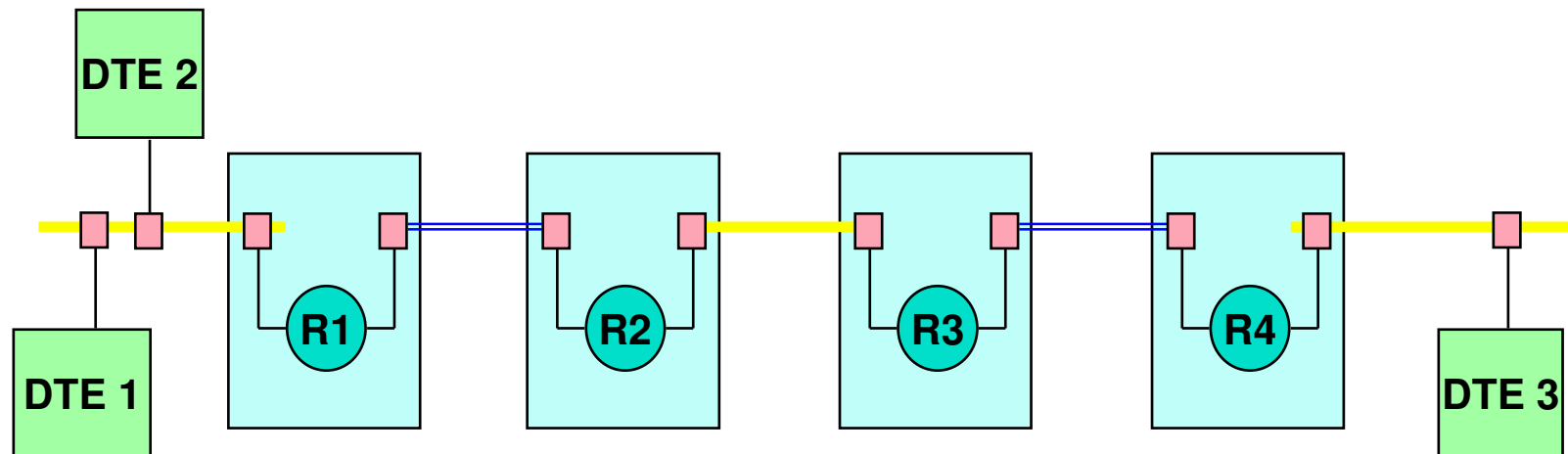



Maximum LAN extension with 3 coax & UTP (Ethernet 10 Mb/s)

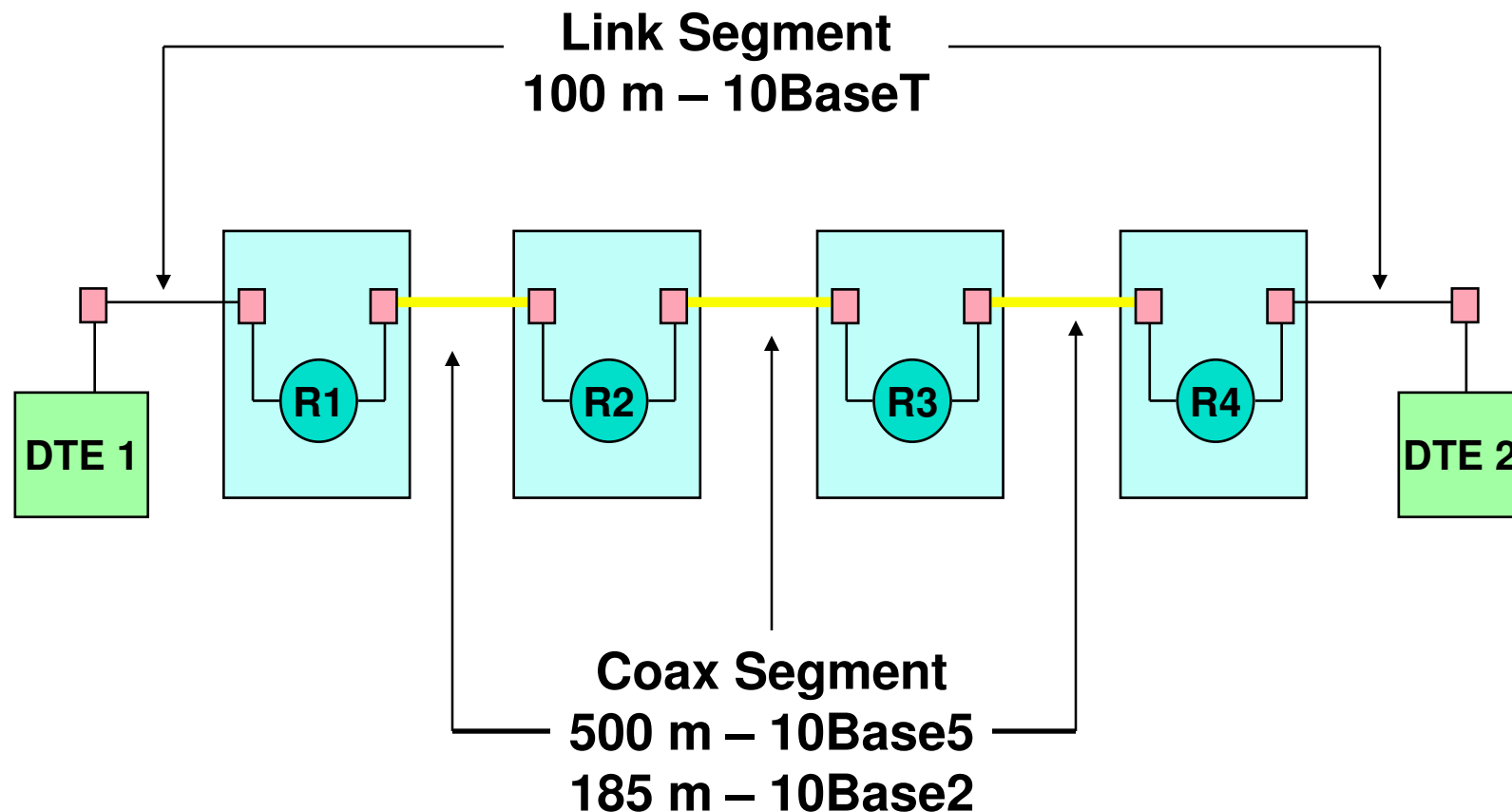



Maximum LAN extension with F.O & UTP links (Ethernet 10 Mb/s)

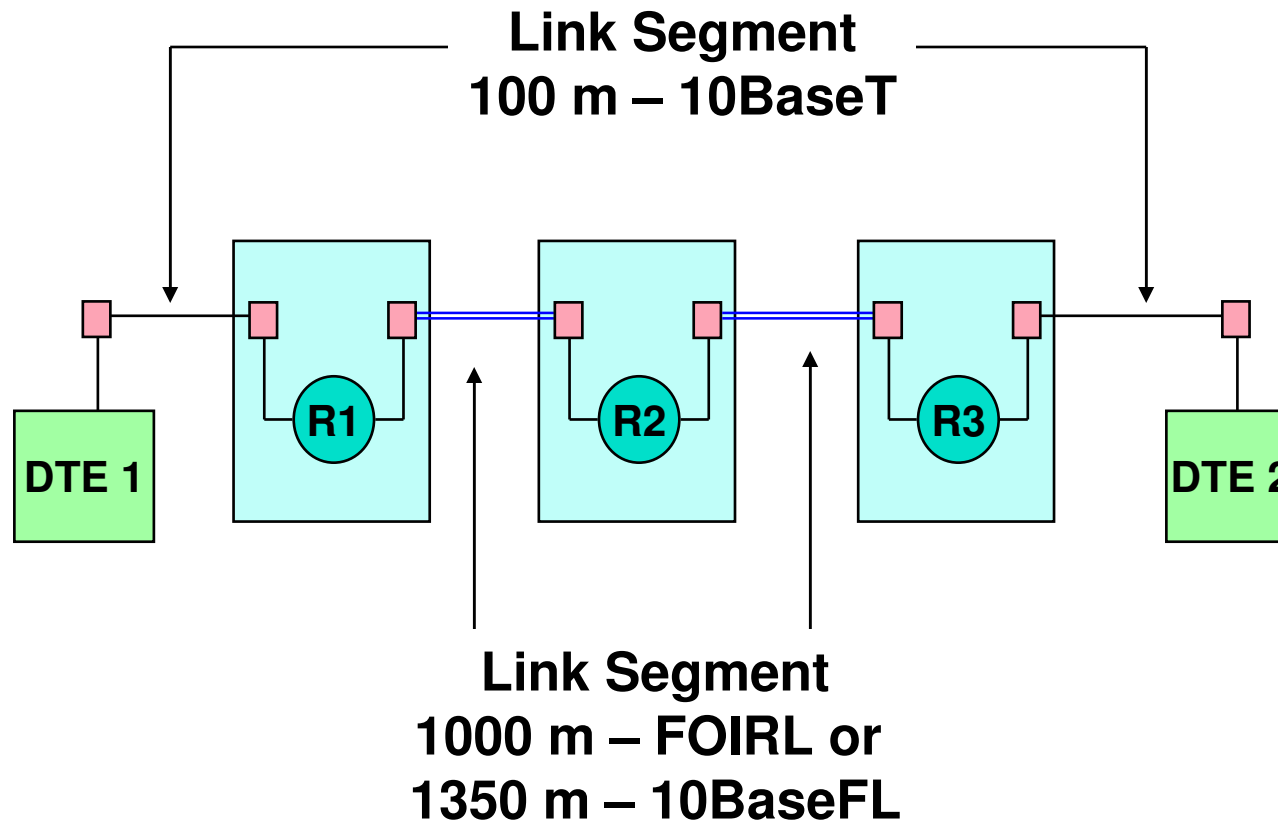



Segment type

■ **mixing segment:**

- a medium that may be connected to more than two Medium Dependent Interfaces

■ **link segment:**

- the point-to-point full-duplex medium connection between two and only two Medium Dependent Interfaces (MDIs).



Segment comparison

Segment Type	Max. num. of MAU per segm.	Max segment Length (m)	Minimum Vp	Max medium delay x segm. (ns)
Mixing segment				
10base5	100	500	0.77 c *	2165
10base2	30	185	0.65 c	950
10baseFP	33 ***	1000 **	0.66 c	5000
Link segment				
FOIRL	2	1000	0.66 c	5000
10baseT ****	2	100	0.59 c	565
10baseFB	2	2000	0.66 c	10000
10baseFL	2	2000	0.66 c	10000

* $c = 3 \times 10^8$ m/s (speed light)

** MAU to passive-star link will not exceed 500 m.

*** Actual number depends on the passive-star characteristics

**** Actual maximum segment length depends on cable characteristics



Delay parameters

- **Path Delay Value (PDV):** The sum of all Segment Delay Values for all segments along a given path.
- **Path Variability Value (PVV):** The sum of all Segment Variability Values for all the segments along a given path.
- **Worst-case path delay value (PDV):** The worst case consists of the path between the two DTEs at opposite ends of the network that have the longest round-trip time
- **Round-trip collision delay:** Each station attempting to transmit must be notified of the contention by the returned "collision" signal within the "collision window"



Collision Window

- 512 bit-time (51.2 μ s)
 - Equal dimension of shortest frame
 - 64 octets = 512 bit
- Transmitting station must detect a collision during shortest transmission frame

56 bit	preamble
8 bit	Start Frame Delimiter
511 bit	(collision window - 1)
575 bit	Max. Round Trip Delay



PDV: Path Delay Value

- $PDV = T1 + T2$
- $PDV \leq 570 \text{ bit} (57 \mu\text{s})$
 - Max. Round trip Delay
 - minus 5 bit-time safety margin

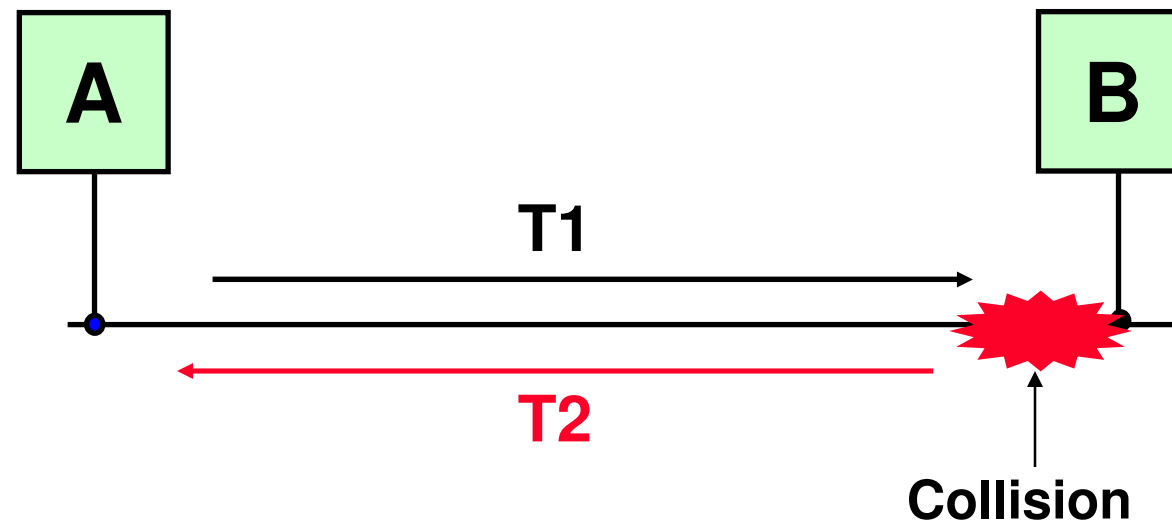



Configuration rules

- Path Delay Value (PDV) less than 570 bit-time
 - the sum of all Segment Delay Values for all segments along a given path (worst case)
- Path Variability Value (PVV) less than 49 bit-time
 - the sum of all Segment Variability Values for all the segments along a given path (worst case)



Reference model

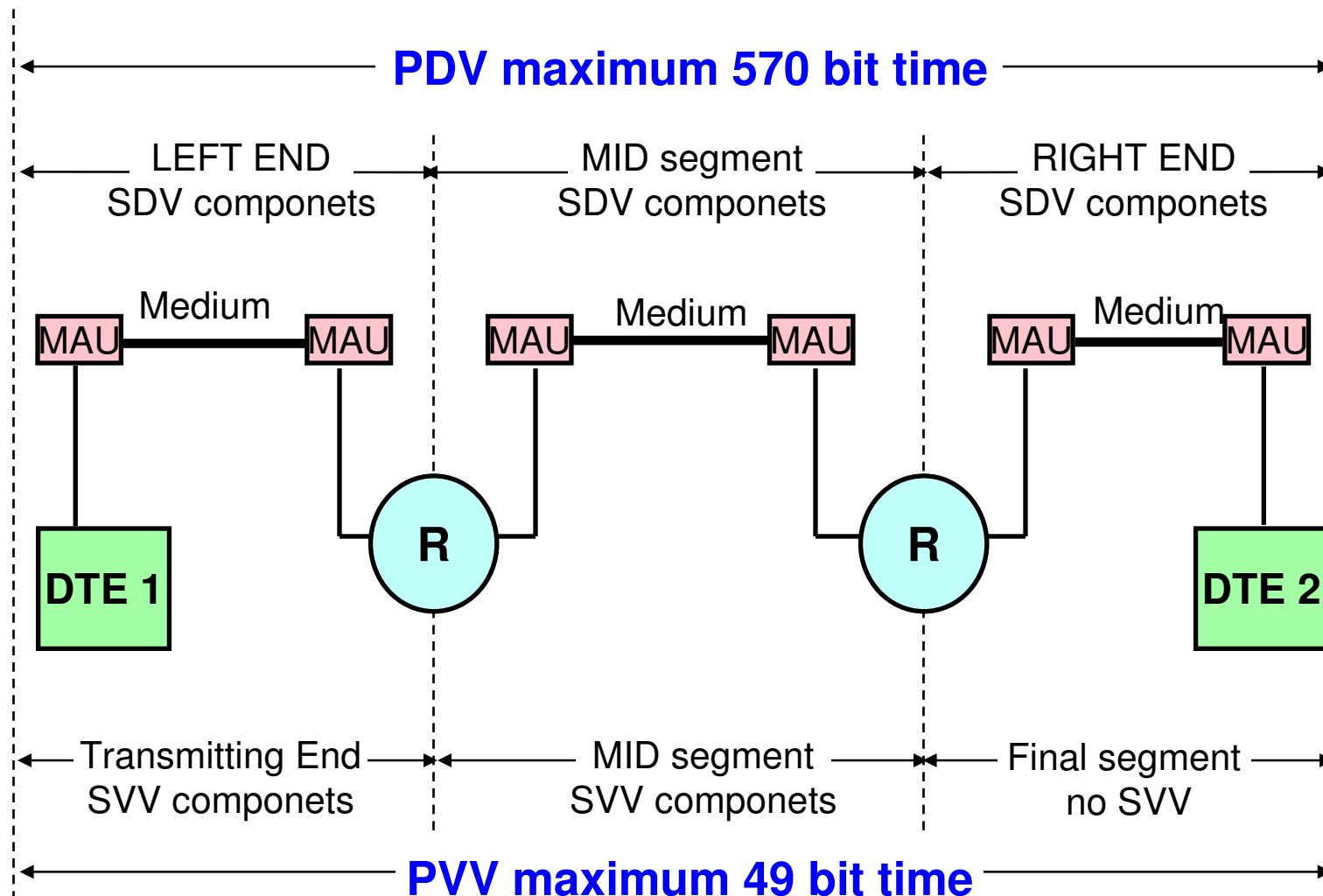



Segment round-trip delay values in bit times (PDV not to exceed 570)

- $SDV = Base + [length * (RT\ delay/meter)]$

Round-trip delay values in Bit time (PDV max. 570)								
Segment Type	Max. length	Left End		Mid-segment		Right End		RT delay/meter
		Base	Max.	Base	Max.	Base	Max.	
10base5	500	11.75	55.05	46.5	89.8	169.5	212.8	0.0866
10base2	185	11.75	30.731	46.5	65.48	169.5	188.48	0.1026
FOIRL	1000	7.75	107.75	29	129	152	252	0.1
10baseT	100*	15.25	26.55	42	53.3	165	176.3	0.113
10baseFP	1000	11.25	111.25	61	161	183.5	284	0.1
10baseFB	2000	N/A**	N/A**	24	224	N/A**	N/A***	0.1
10baseFL	2000	12.25	212.25	33.5	233.5	156.5	356.5	0.1
Exc. len. AUI	48	0	4.88	0	4.88	0	4.88	0.1026

* Actual maximum segment length depends on cable characteristics;

** Not Applicable, 10BASE-FB does not support end connections.



Segment variability values in bit times (PVV not to exceed 49)

Segment variability values in Bit time (PVV max. 49)		
Segment type	Transmitting End	Mid segment
Coax	16	11
Link except 10baseFB	10.5	8
10baseFB	N/A**	2
10baseFP	11	8

****Not Applicable, 10BASE-FB does not support end connections.**