

European Normative EN50173-1 for generic/structured cabling system

Pietro Nicoletti

Studio Reti s.a.s

piero[at]studioreti.it

www.studioreti.it

Copyright note

- These slides are protected by copyright and international treaties. The title and the copyrights concerning the slides (inclusive, but non only, every image, photograph, animation, video, audio, music and text) are the author's (see Page 1) property.
- The slides can be copied and used by research institutes, schools and universities affiliated to the Ministry of Public Instruction and the Ministry of University and Scientific Research and Technology, for institutional purpose, not for profit. In this case there is not requested any authorization.
- Any other complete or partial use or reproduction (inclusive, but not only, reproduction on discs, networks and printers) is forbidden without written authorization of the author in advance.
- The information contained in these slides are believed correct at the moment of publication. They are supplied only for didactic purpose and not to be used for installation-projects, products, networks etc. However, there might be changes without notice. The authors are not responsible for the content of the slides.
- In any case there can not be declared conformity with the information contained in these slides.
- In any case this note of copyright may never be removed and must be written also in case of partial use.

EN 50173-1 foreword (1st part)

- Approved by CENELEC in November 2002
 - This European Standard, EN 50173-1, supersedes both EN 50173:1995 and EN 50173:1995/A1:2000
 - Modify previous Category 5 and Class D specifications
 - Define characteristics for Category 5, 6, 7 cabling components and Class D, E, F generic cabling systems
 - Do not specify category 5E but enhance category 5 and class D parameters that are equivalent to the American TIA/EIA 5E category.

EN 50173-1 foreword (2nd part)

- Essential changes include the following:
 - Centralized generic cabling in addition to hierarchical three-level topology
 - new modelling of the horizontal cabling subsystem with an optional consolidation point
 - new modelling of the horizontal cabling subsystem with an optional consolidation point
 - new channel Classes E and F for balanced cabling and associated component Categories 6 and 7
 - classification of optical fibre cabling channels and associated component requirements
 - limits for all channel parameters based on formulae instead of discrete values at key frequencies

EN 50173-1 foreword (3th part)

- The first edition of this European Standard had been developed to enable the application-independent pre-cabling of office premises.
- Its basic principles, however, are applicable also in various other situations including industrial premises and residential buildings

EN 50173-1 scope

- This European Standard specifies generic cabling for use within premises which may comprise single or multiple buildings on a campus.
- It covers balanced cabling and optical fibre cabling.
- Safety (electrical safety and protection, fire, etc.) and electromagnetic compatibility (EMC) requirements are outside the scope of this European Standard and are covered by other standards and regulations.

EN 50173-1: applications

- The standard is optimised for premises in which the maximum distance over which telecommunications services have to be distributed is 2000 m.
- The principles of this European Standard may also be applied to larger installations.
- This standard contain informations and specifications usefull for generic cabling system project

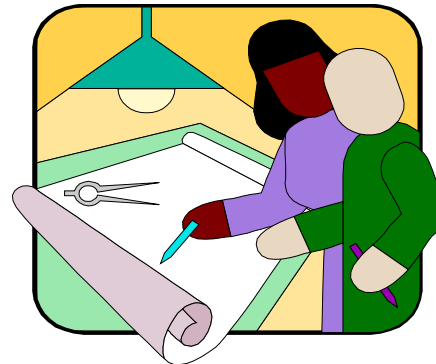
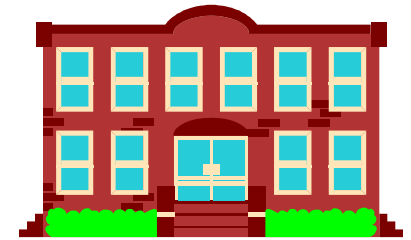

Generic (structured) Cabling Topology

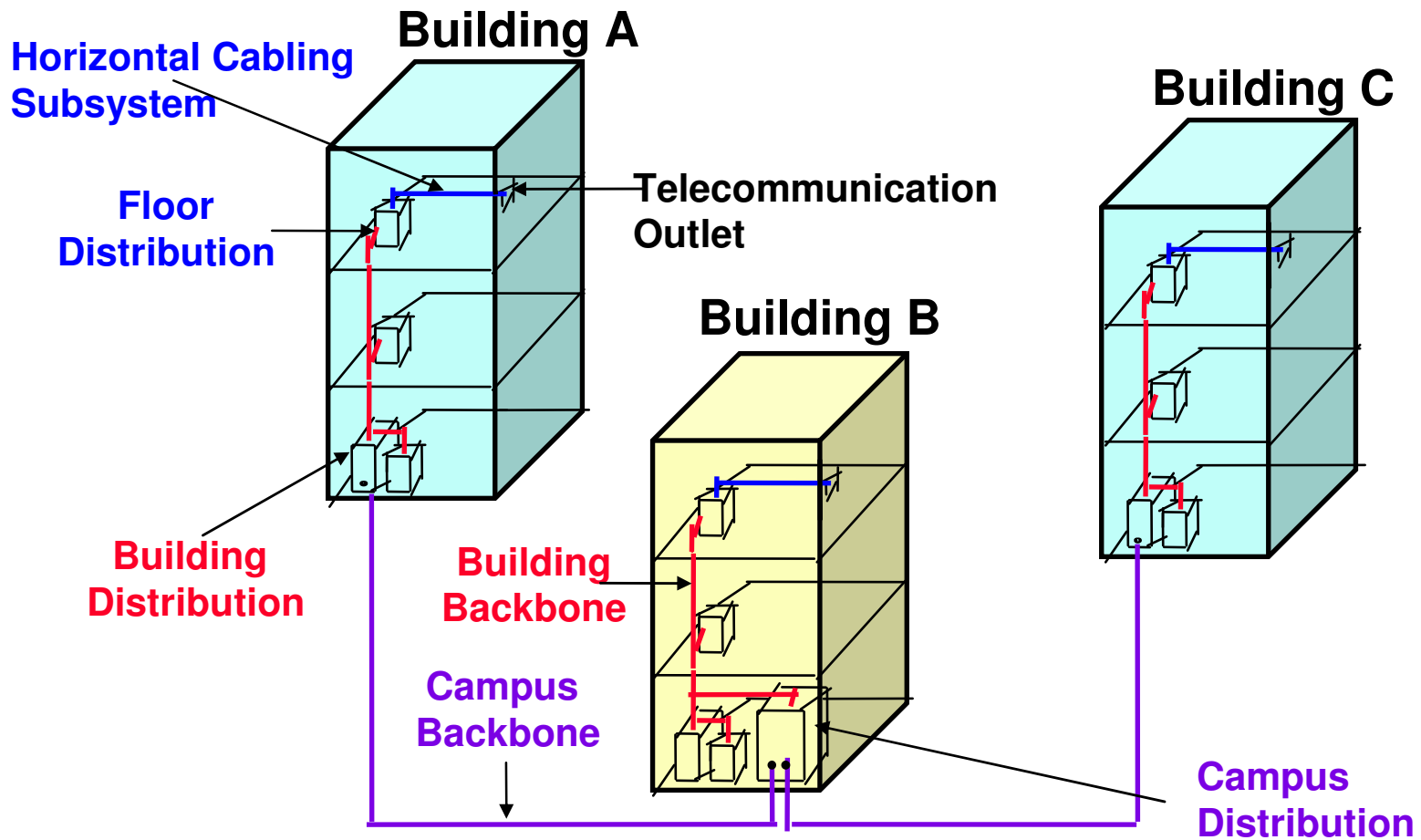

Others Normative References

- EN 50174 -1
 - Information technology – Cabling installation–
Part 1: Specification and quality assurance
- EN 50174-2
 - Information technology – Cabling installation
–Part 2: Installation planning and practices
inside buildings
- EN 50174-3
 - Cabling system installation – Part 3:
Installation planning and practices outside
buildings

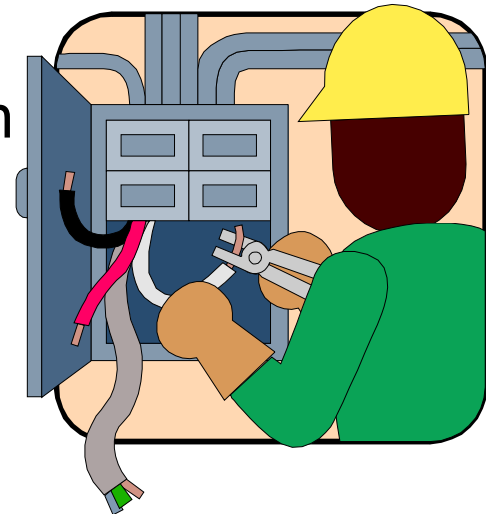

Functional generic cabling elements

- campus distributor (CD);
 - campus backbone cable;
- building distributor (BD);
 - building backbone cable;
- floor distributor (FD);
 - horizontal cable;
 - equipment cord (EC)
- consolidation point (CP);
 - consolidation point cable (CP cable);
 - multi-user TO assembly;
- work area (WA);
 - work area cord (WAC)
- telecommunications outlet (TO).

Generic cabling system structure

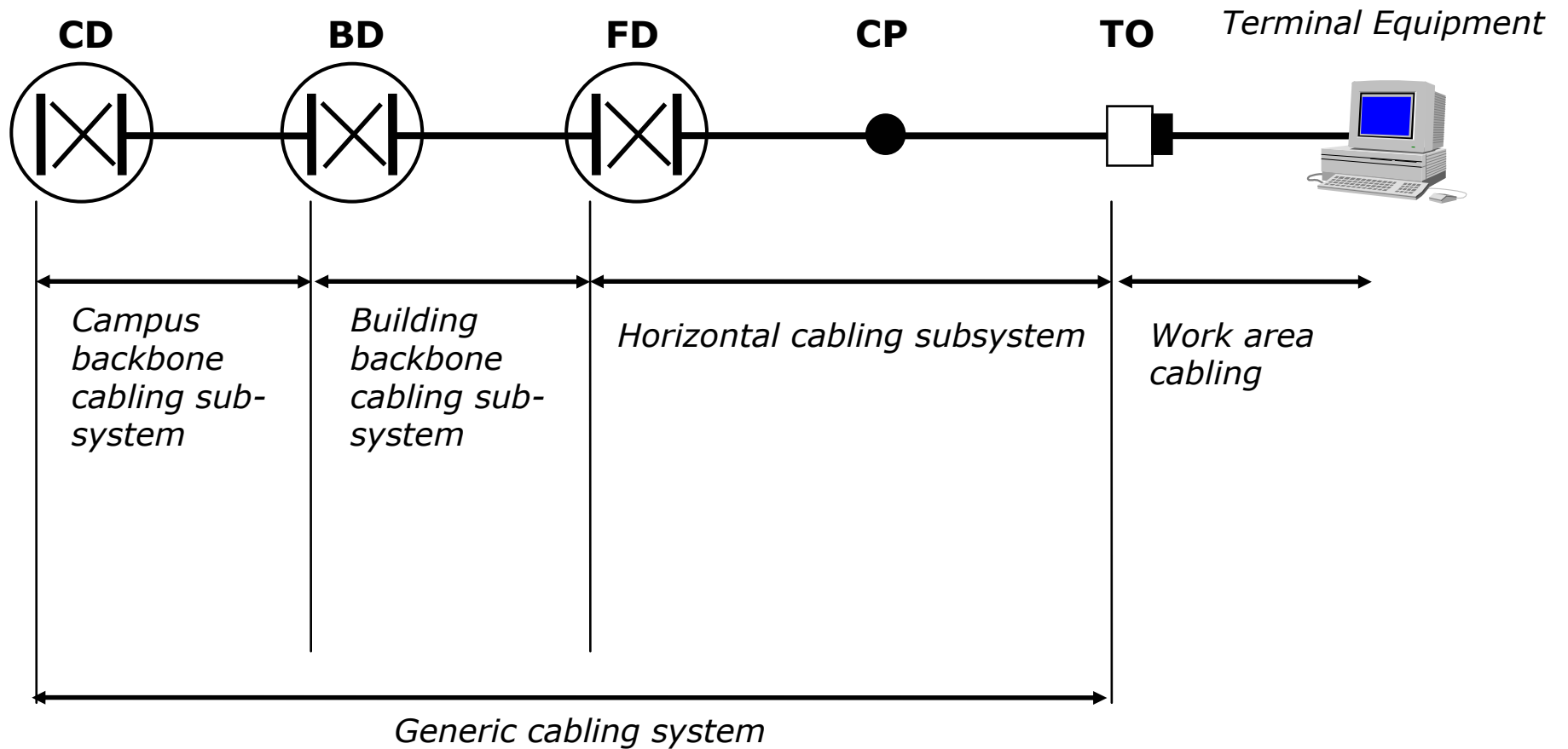

Generic cabling system hierarchy

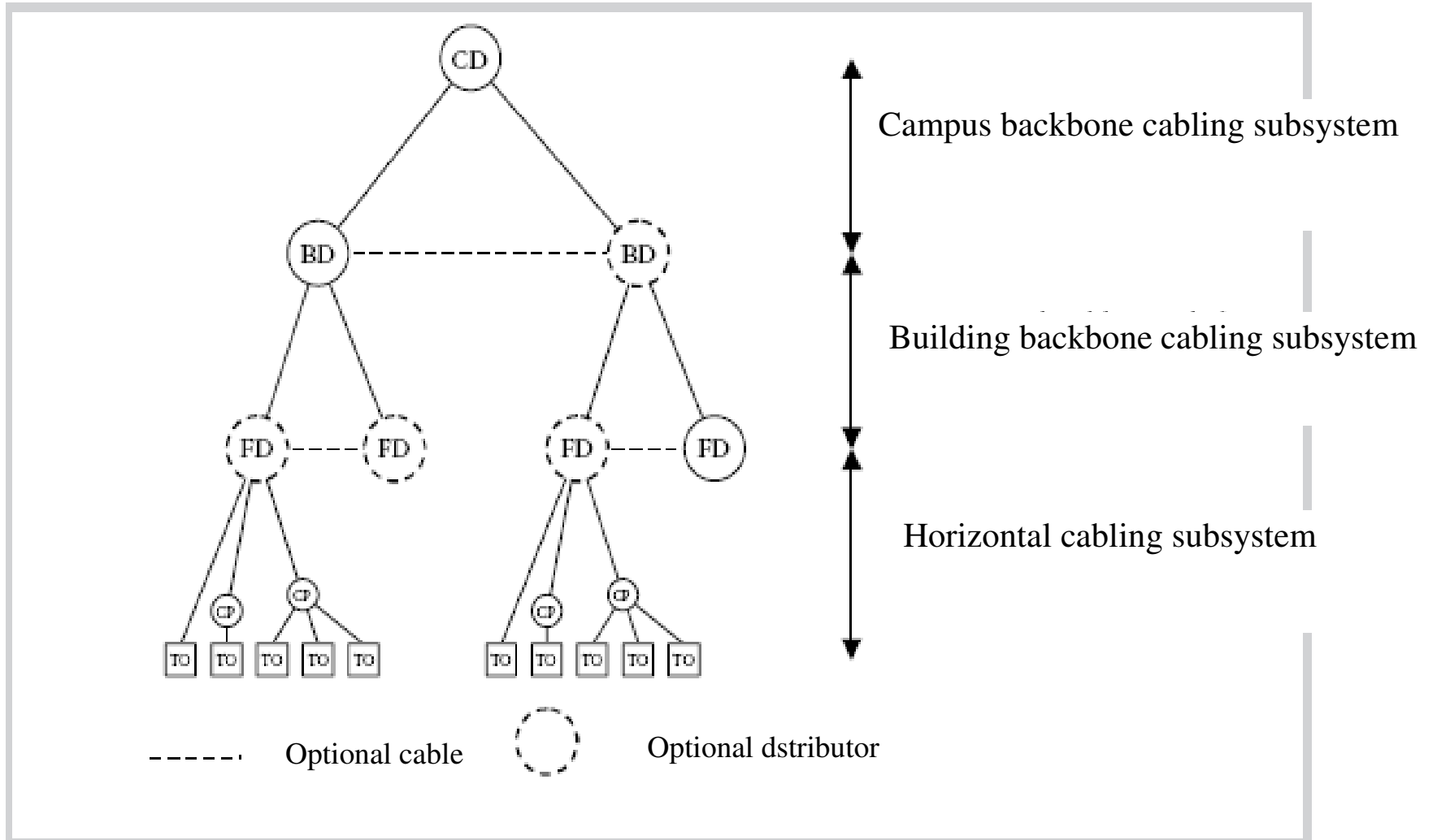

Accommodation of functional elements

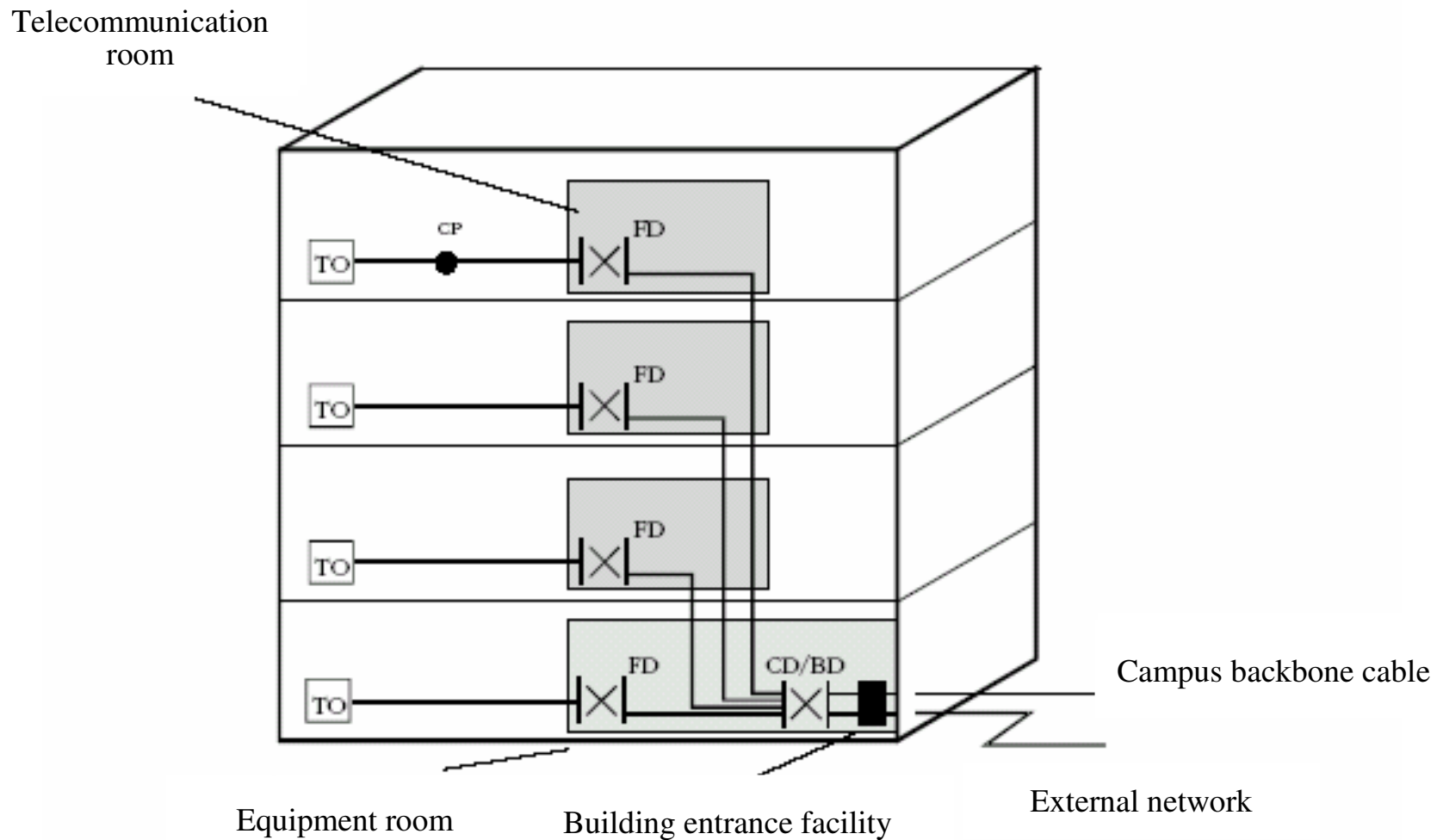

Interconnect model

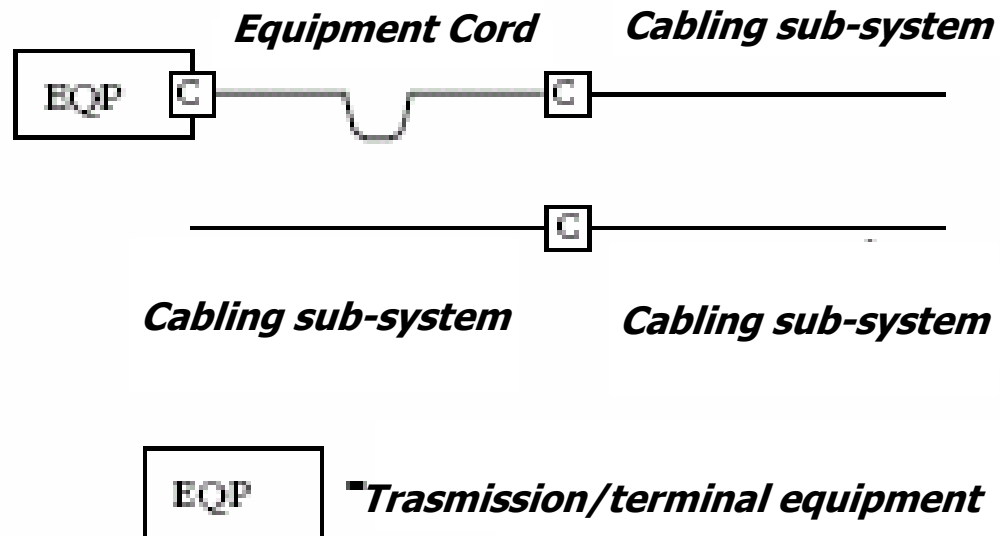

Crossconnect model

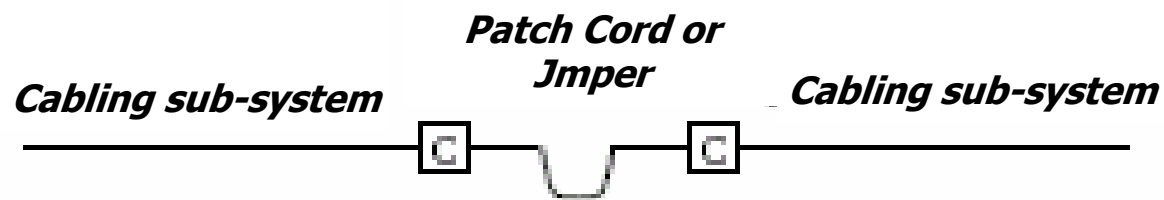
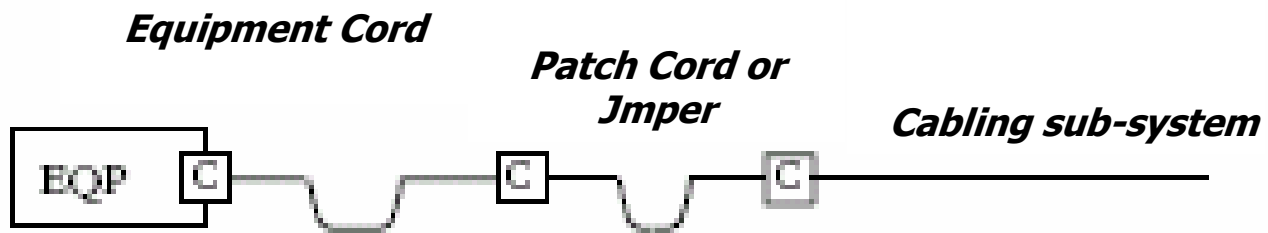

Trasmission/terminal equipment

Test and equipment interfaces

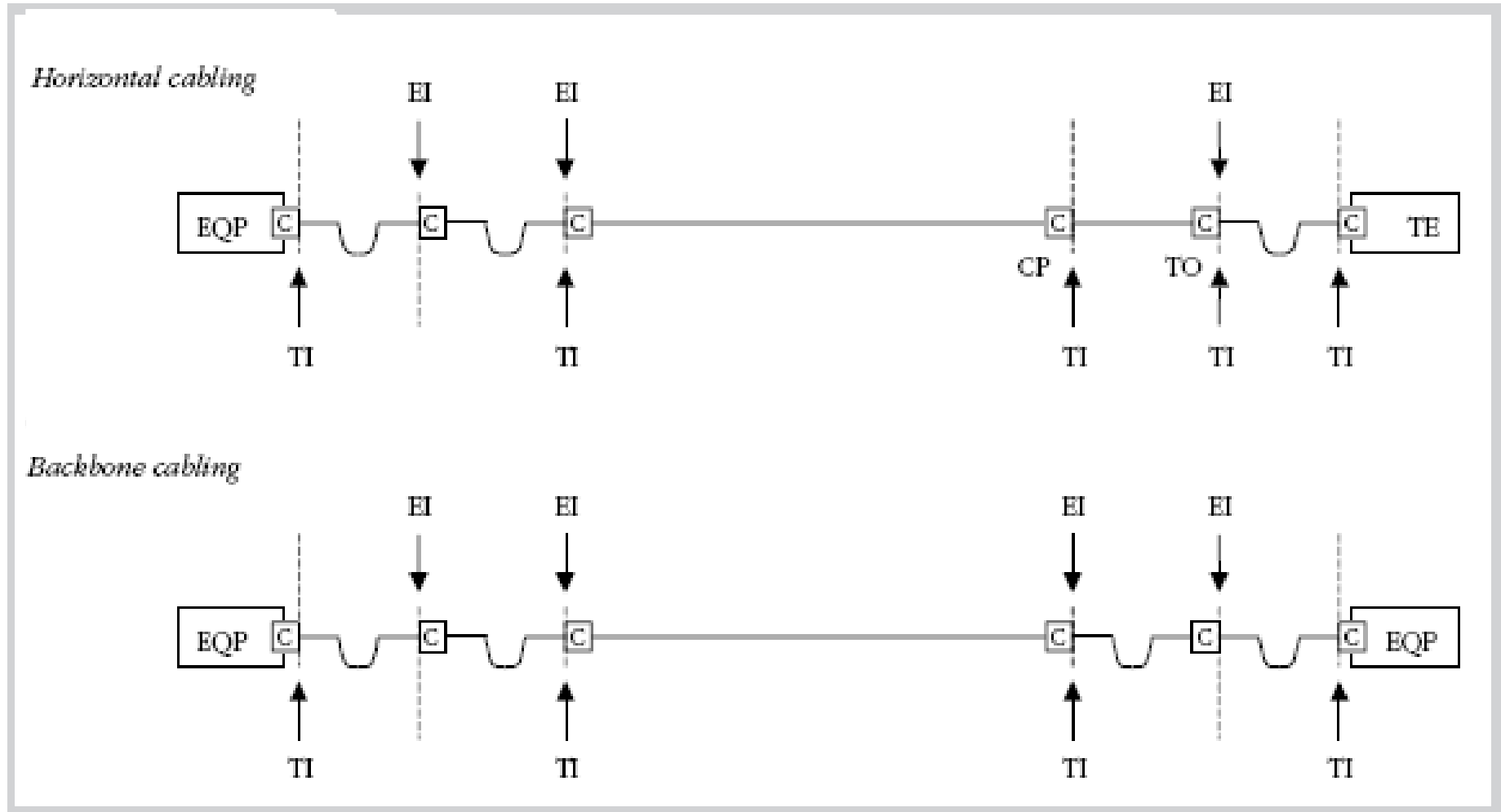

Dimensioning and configuring

- The number and type of subsystems that are included in a generic cabling implementation depends upon:
 - the geography and size of the campus or building;
 - the strategy of the user.
- Usually there would be:
 - one campus distributor;
 - one building distributor per building;
 - one floor distributor per floor.
 - If the premises comprise only a single building which is small enough to be served by a single building distributor, there is no need for a campus backbone cabling subsystem.

Dimensioning and configuring

- Large buildings may be served by multiple building distributors interconnected via a campus distributor.
- The design of the floor distributor shall ensure that the lengths of patch cords, jumpers and equipment cords are minimised and administration should ensure that the design lengths are maintained during operation.
- Distributors should be located such that the resulting cable lengths are not longer than:
 - **100 m** for *Horizontal cabling*
 - **2000 m** total path of = *Horizontal cabling + building backbone + campus backbone*

Distribution points dimensioning and configuring

- There should be a minimum of one floor distributor for every 1000 m² of floor space reserved for offices.
- A minimum of one floor distributor should be provided for every floor.
- If floor is sparsely populated (e.g. a lobby), it is permissible to serve this floor from the floor distributor located on an adjacent floor
- If a floor area extends beyond 1000 m², additional floor distributors may need to be installed to more effectively service the work area.
- The functions of multiple distributors may be combined.
- For reliability reasons, redundancy may be built into a cabling design.

Example of a generic cabling system with combined BD and FD

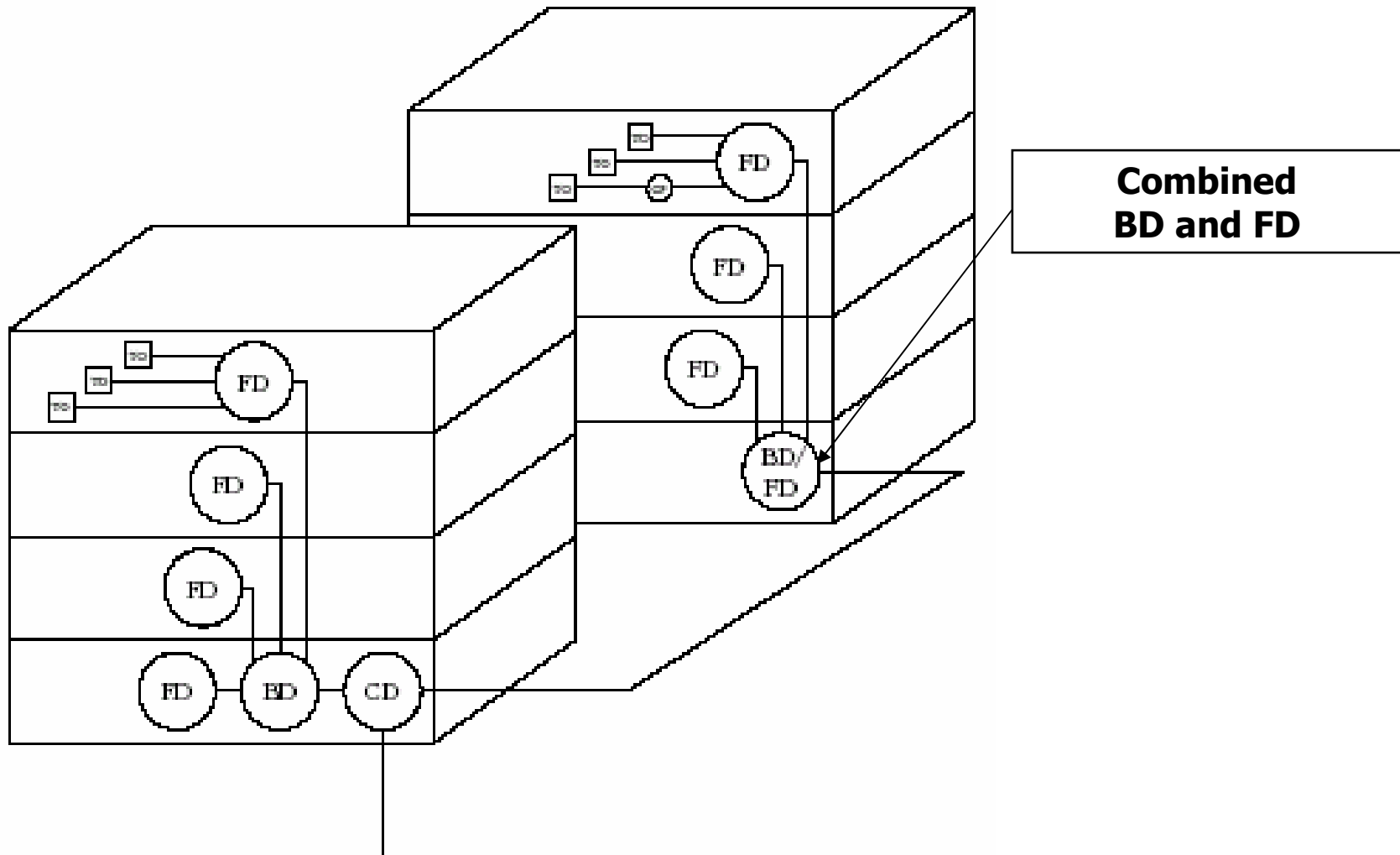

**Combined
BD and FD**

Connection of functional elements providing redundancy

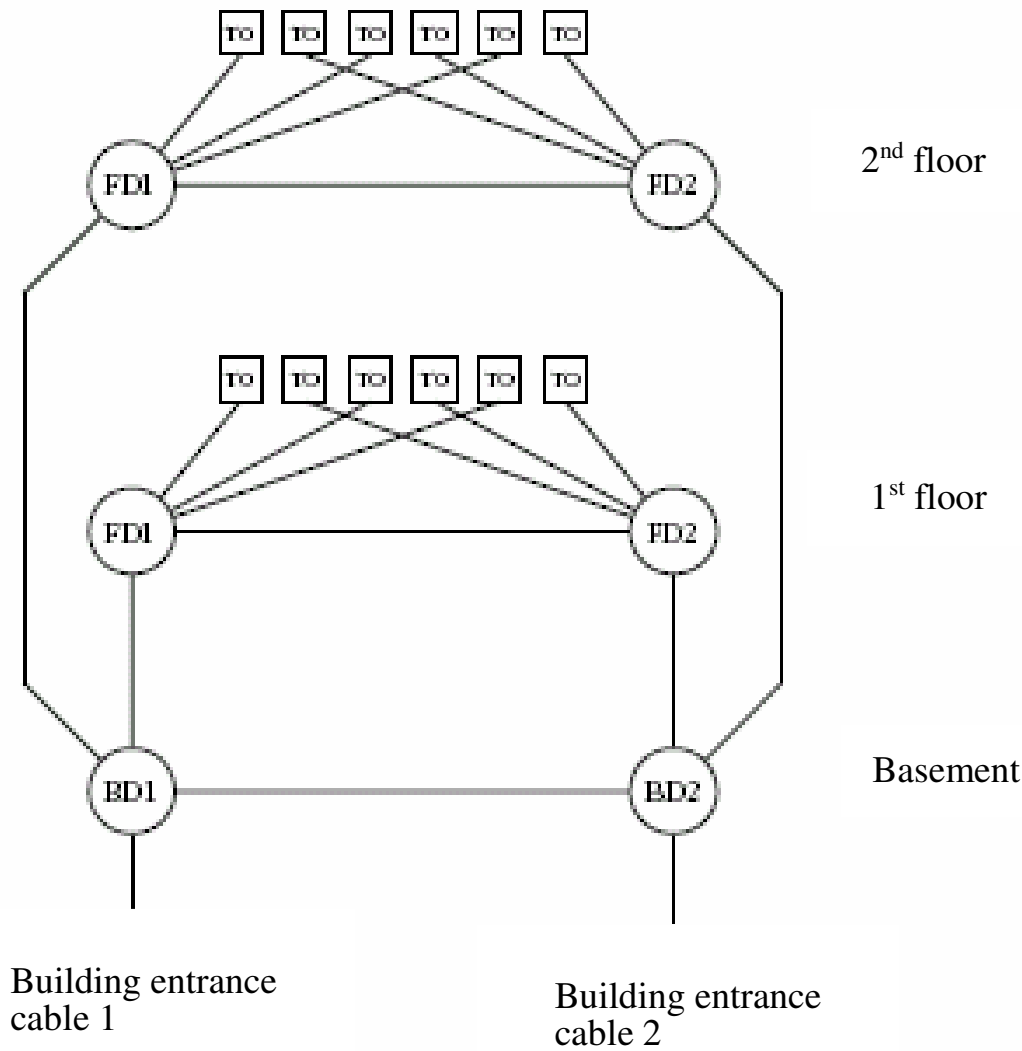

8 contacts connecting hardware - category 5, 6 and 7

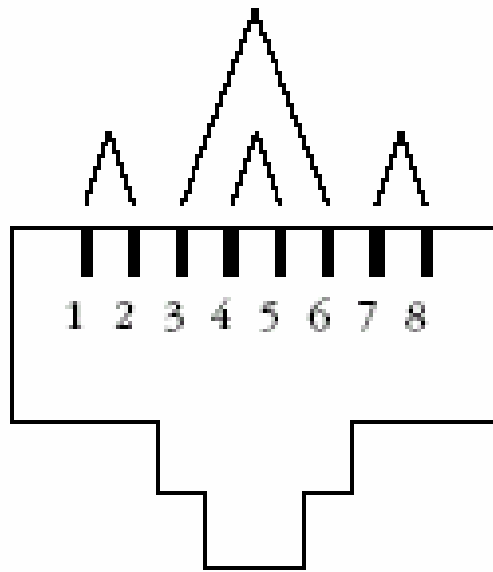

***Category 5 and 6
connecting hardware***

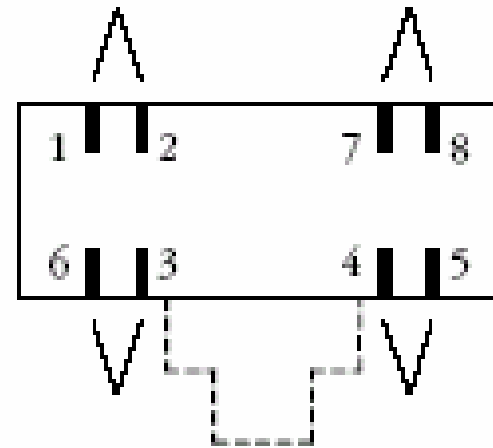

***Category 7
connecting hardware***

Work Area design

- The design of generic cabling should provide for telecommunications outlets to be installed throughout the usable floor space.
- Telecommunications outlets may be presented singly, or in groups.
- Two pairs per TO may be used as an alternative to four pairs, however this requires pair reassignment and will not support some applications
- The maximum attenuation ratio of flexible cables (patch) defined as their **attenuation/ insertion loss** (dB/100 m) compared to that of installation cables, is **1,5**.

Work Area design

- Each individual work area shall be served by a minimum of two TOs:
 - The first outlet should be for four pair balanced cable terminated
 - Category 5, 6 or 7
 - The second outlet may be for two optical fibres terminated or four pair balanced cable terminated
 - Category 5, 6 or 7
 - Each telecommunications outlet shall have a permanent means of identification that is visible to the user
- Devices such as baluns and impedance matching adapters, if used, shall be external to the outlet

Work Area design

- Single user TO assembly:
 - serves a single work area
 - the TO assembly should be located in user-accessible locations;
 - The performance contribution of work area cords, patch cords, jumpers and equipment cords shall be taken into account to ensure that the channel requirements (Class: A, B, C, D, or F)

Work Area design

- Multi-user TO assembly (MUTO) in an open office environment, a single assembly of TOs may be used to serve more than one work area:
 - Shall be located in an open work area so that each furniture cluster is served by at least one multi-user TO assembly
 - Should be limited to serving a maximum of 12 work areas
 - Should be located in user accessible, permanent locations
 - Shall not be installed in ceiling spaces or any obstructed areas
 - The performance contribution of work area cords, patch cords, jumpers and equipment cords shall be taken into account to ensure that the channel requirements

Consolidation Point

- Connection point in the horizontal cabling subsystem between a floor distributor and a telecommunications outlet.
- The installation of a consolidation point in the horizontal cabling between the floor distributor and the telecommunications outlet may be useful in an open office environment where the flexibility of relocating TOs in the work area is required.
 - Like open-space where consolidation point act as a Multi-User Telecommunication Outlet (MUTO)
- One consolidation point is permitted between a FD and any TO.

Consolidation Point

- In addition, where a consolidation point is used:
 - shall be located so that each work area group is served by at least one consolidation point;
 - should be limited to serving a maximum of 12 work areas;
 - should be located in accessible permanent locations such as ceiling voids and under floors;
 - for balanced cabling, the effect of multiple connections in close proximity on transmission performance should be taken into consideration when planning the cable lengths between the floor distributor and the consolidation point;
 - a consolidation point has labelling and documentation requirements and shall be covered in the cabling administration system.

Horizontal cabling design

- The selection of balanced cabling components will be determined by the class of applications to be supported by the cabling:
 - Category 5 components provide Class D balanced cabling performance;
 - Category 6 components provide Class E balanced cabling performance;
 - Category 7 components provide Class F balanced cabling performance.
- Cables and connections of different categories may be mixed within a channel however the resultant cabling performance will be determined by the category of the lowest performing component.

Horizontal cabling models

- 4 different models can be used for cabling design:
 - *Interconnect - TO Model*
 - *Crossconnect - TO Model*
 - *Interconnect - CP -TO Model*
 - *Crossconnect - CP - TO Model*

Horizontal cabling: *Interconnect - TO Model*

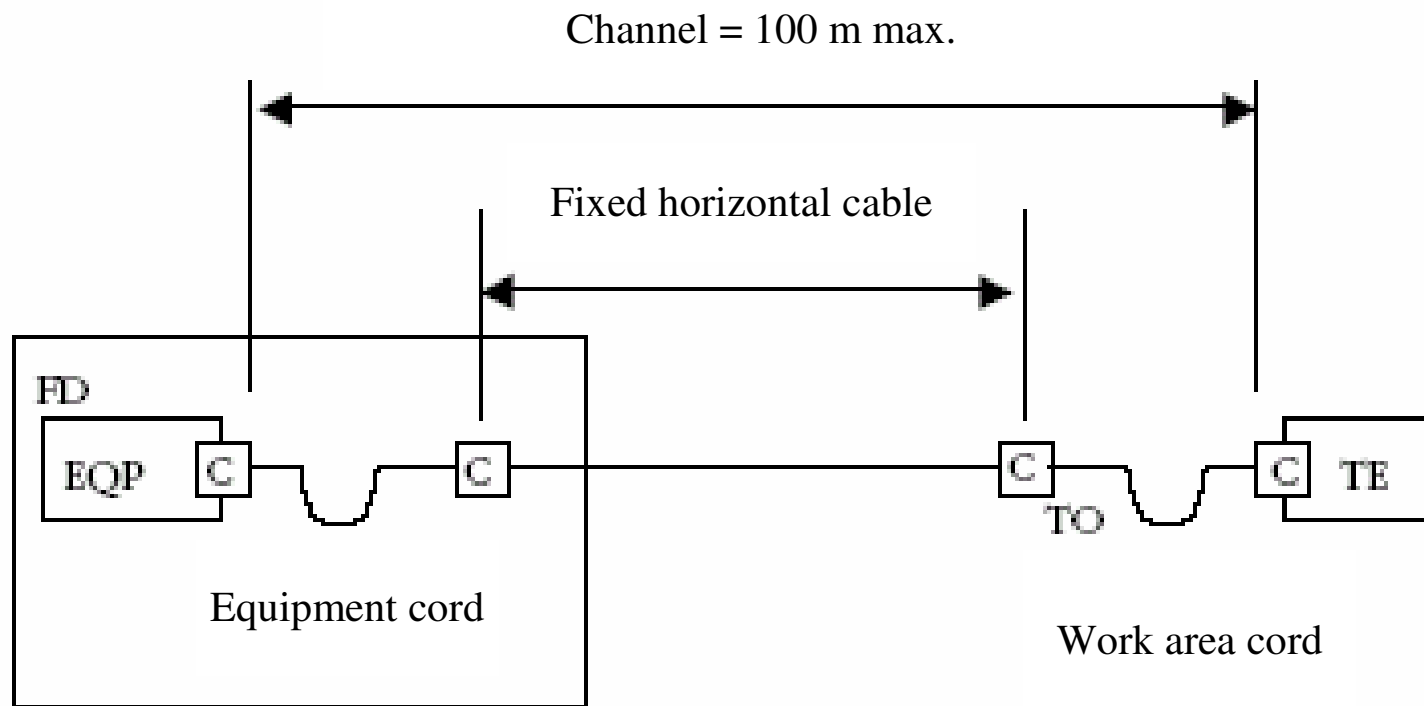

Horizontal cabling: *Crossconnect - TO Model*

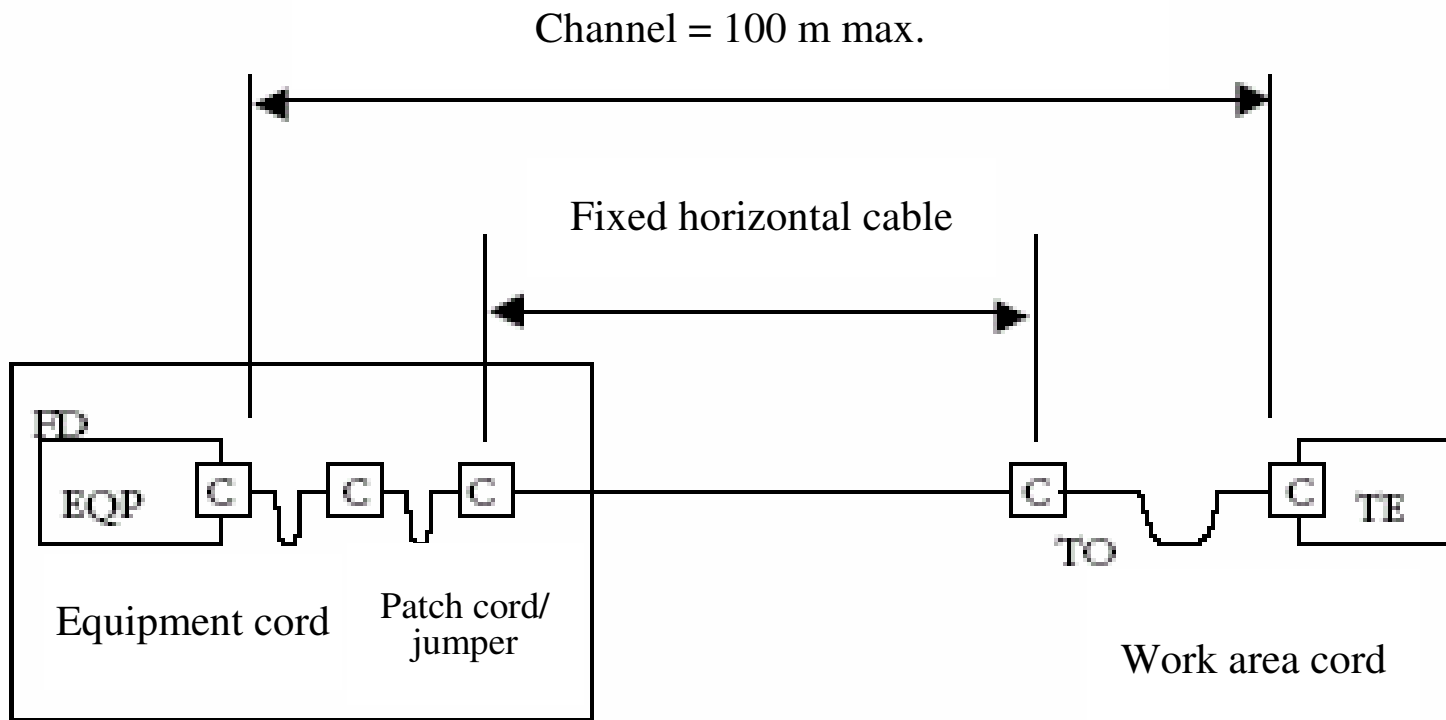

Horizontal cabling: *Interconnect - CP - TO Model*

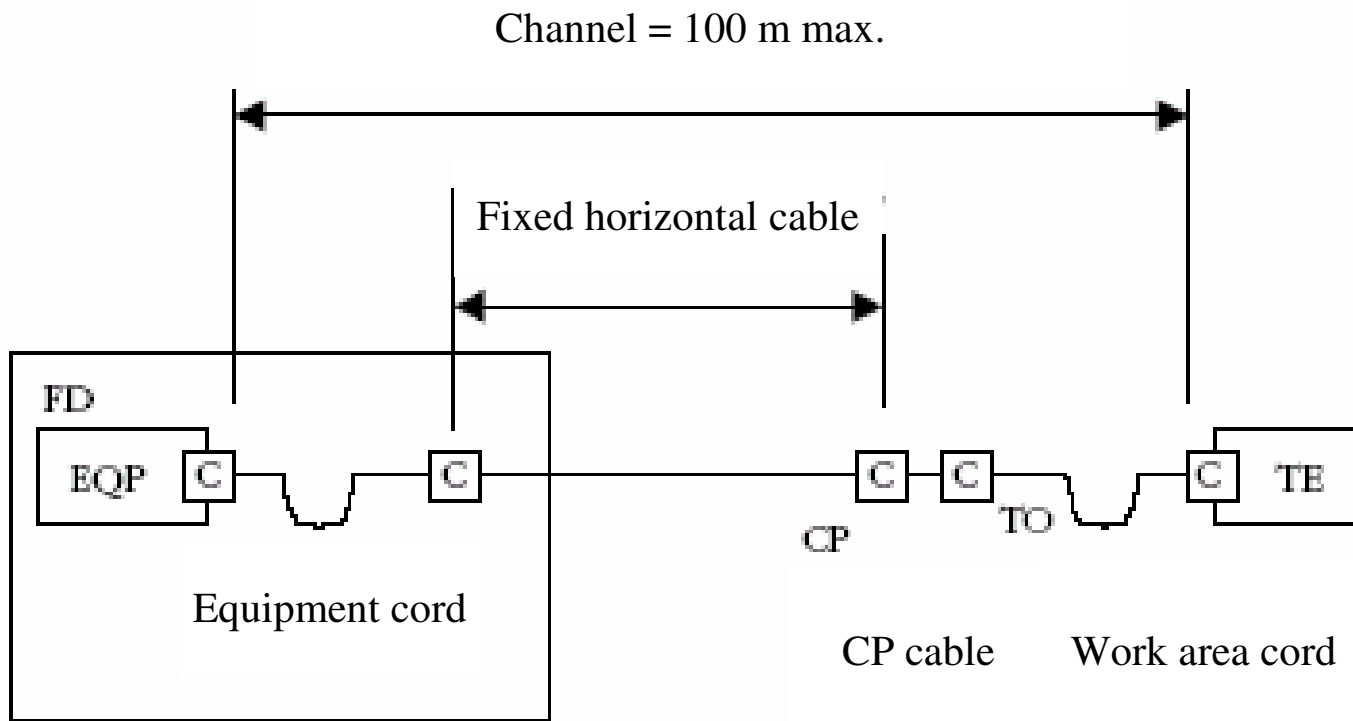

Horizontal cabling: *Crossconnect - CP - TO Model*

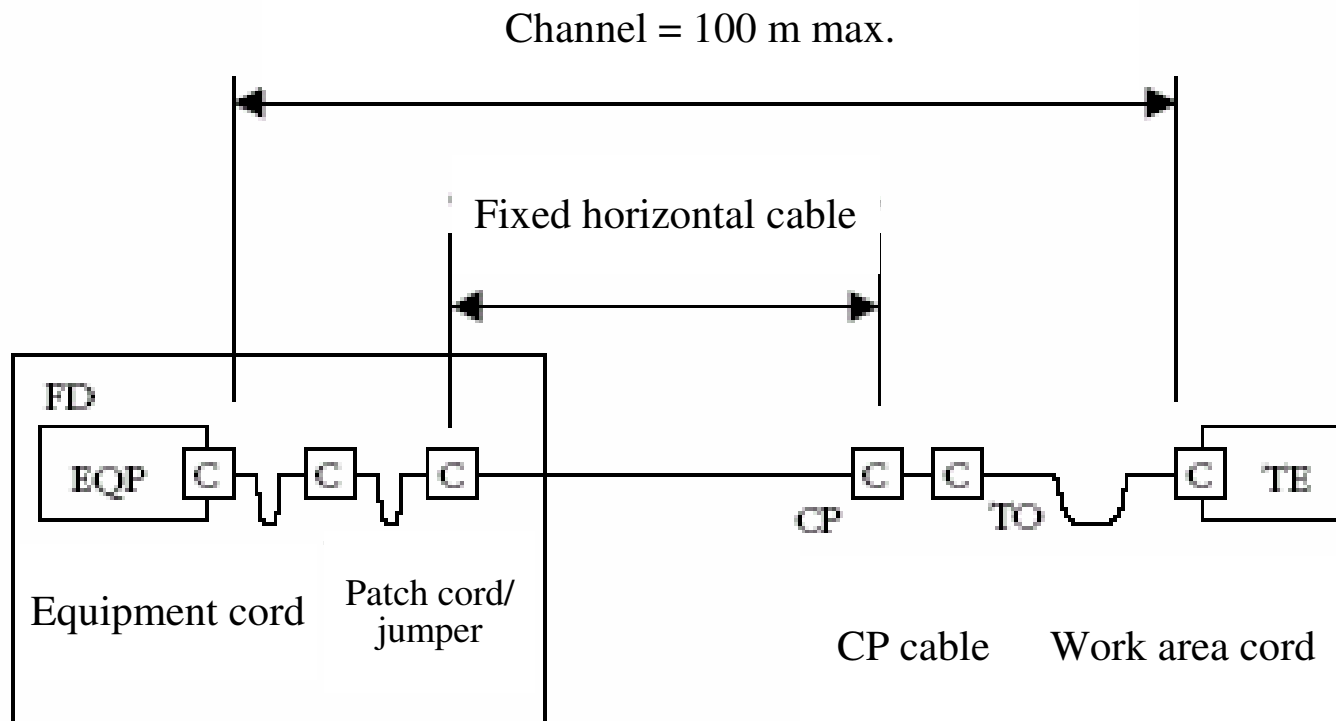

Horizontal cabling: maximum length

- The length of the permanent link and the channel depending by CP and patch cable characteristics and length
- CP cable can be flexible/stranded or solid like the installation cable
 - If flexible cable is used the maximum **attenuation ratio** of flexible cables, defined as their attenuation/insertion loss (dB/100 m), compared to that of installation cables, is **1,5**.

Horizontal channel equations

Model	Model equations		
	Class D	Class E	Class F
Interconnect – TO	$H = 109 - FX$	$H = 107 - 3^{(a)} - FX$	$H = 107 - 2^{(a)} - FX$
Cross-connect – TO	$H = 107 - FX$	$H = 106 - 3^{(a)} - FX$	$H = 106 - 3^{(a)} - FX$
Interconnect - CP – TO	$H = 107 - FX - CY$	$H = 106 - 3^{(a)} - FX - CY$	$H = 106 - 3^{(a)} - FX - CY$
Cross-connect - CP – TO	$H = 105 - FX - CY$	$H = 105 - 3^{(a)} - FX - CY$	$H = 105 - 3^{(a)} - FX - CY$
<p><i>H</i> Maximum length of the fixed horizontal cable (m)</p> <p><i>F</i> Combined length of patch cords, jumpers, equipment and work area cords (m)</p> <p><i>C</i> Length of the CP cable (m).</p> <p><i>X</i> Ratio of flexible cable attenuation (dB/m) to fixed horizontal cable attenuation (dB/m)</p> <p><i>Y</i> Ratio of CP cable attenuation (dB/m) to fixed horizontal cable attenuation (dB/m)</p>			
(a) This length reduction is to provide an allocated margin to accommodate insertion loss deviation.			
For operating temperatures above 20 °C, H should be reduced by 0,2% per °C for screened cables and 0,4% per °C (20 °C to 40 °C) and 0,6% per °C (> 40 °C to 60 °C) for unscreened cables.			

General restrictions for horizontal cabling design

- The following general restrictions apply:
 - the physical length of the channel shall not exceed 100 m
 - the physical length of the fixed horizontal cable shall not exceed 90 m and may be less depending on the length of CP cables and cords used and the number of connections;
 - where a multi-user TO assembly is used, the length of the work area cord should not exceed 20 m;
 - when used, a CP should be located at least 15 m from the floor distributor in order to reduce the effect of multiple connections in close proximity on NEXT and return loss;
 - the length of patch cords or jumpers shall not exceed 5 m.

Classification of balanced cabling channels

- This standard specifies the following classes for balanced cabling:
 - Class A is specified up to 100 kHz.
 - Class B is specified up to 1 MHz.
 - Class C is specified up to 16 MHz.
 - Class D is specified up to 100 MHz.
 - Class E is specified up to 250 MHz.
 - Class F is specified up to 600 MHz.

Generic cabling performance

- Performance are dependent of the following characteristics:
 - Attenuation/insertion loss
 - NEXT
 - PSNEXT
 - ACR
 - PSACR
 - Return Loss
 - ELFEXT
 - PSELFEXT
- Limits are different for:
 - permanent link
 - channel

Channel and Permanent Link

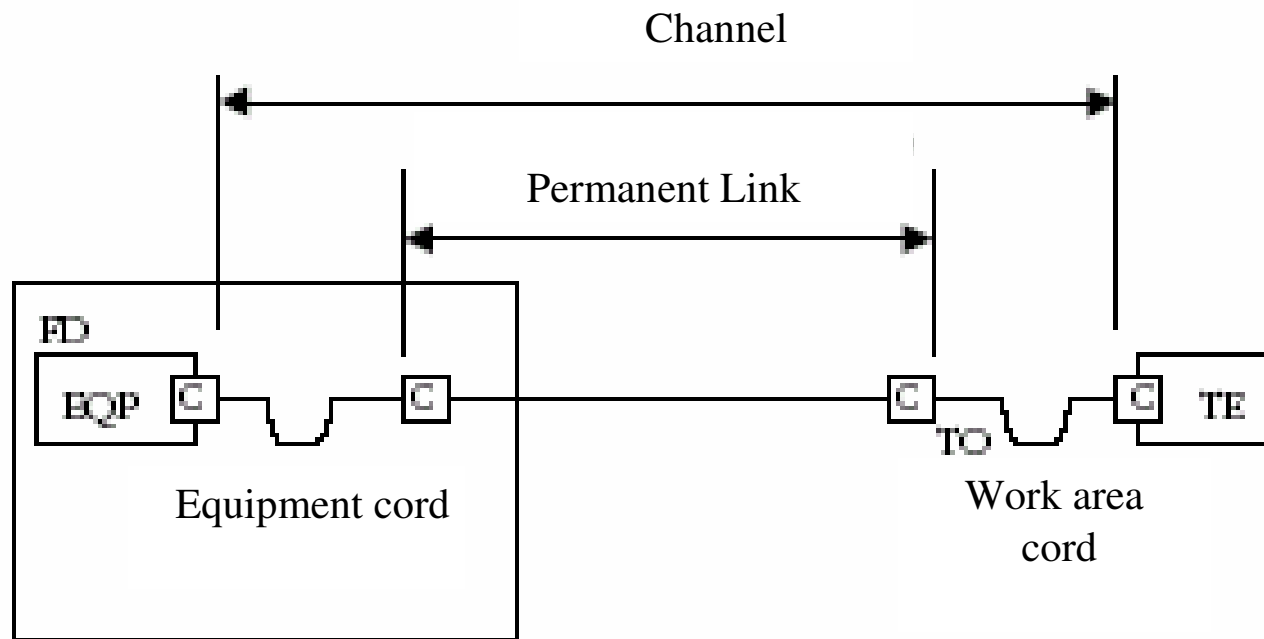

Channel and Permanent Link with CP

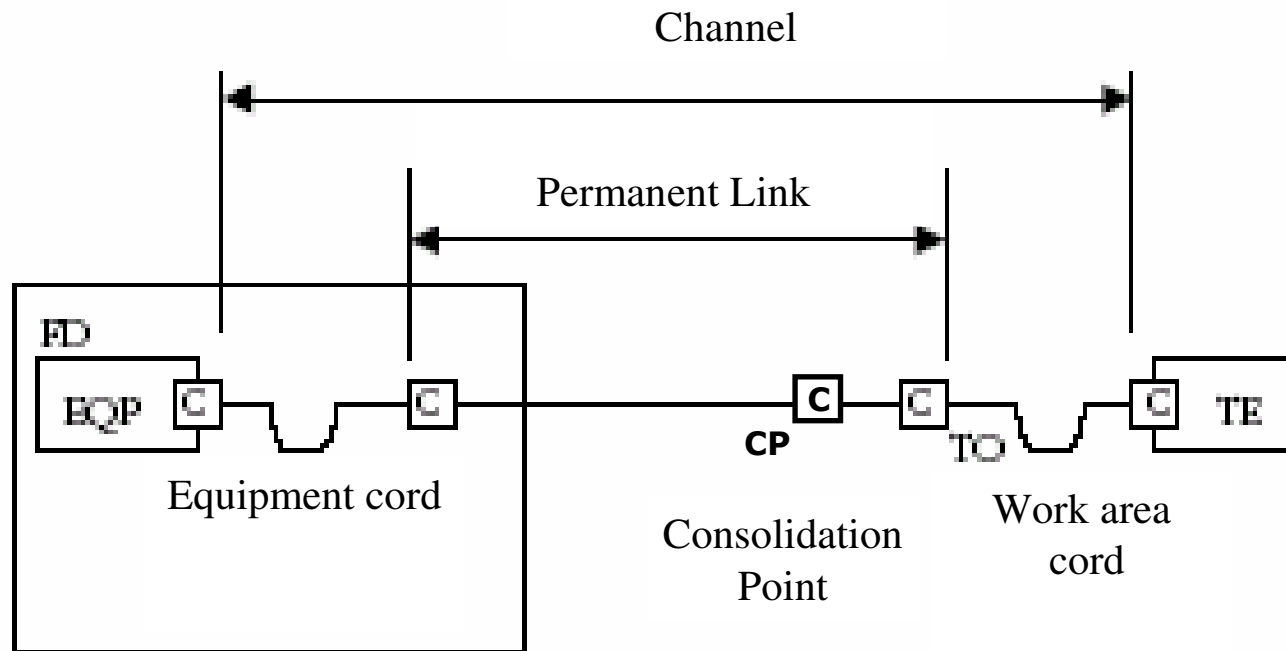

Channel attenuation

Frequenza Frequency MHz	Attenuazione massima Maximum attenuation dB					
	Classe A Class A	Classe B Class B	Classe C Class C	Classe D Class D	Classe E Class E	Classe F Class F
0,1	16,0	5,5	N/A	N/A	N/A	N/A
1,0	N/A	5,8	4,2	4,0	4,0	4,0
16,0	N/A	N/A	14,4	9,1	8,3	8,1
100,0	N/A	N/A	N/A	24,0	21,7	20,8
250,0	N/A	N/A	N/A	N/A	35,9	33,8
600,0	N/A	N/A	N/A	N/A	N/A	54,6

Channel NEXT

Frequenza Frequency MHz	NEXT minima Minimum NEXT dB					
	Classe A Class A	Classe B Class B	Classe C Class C	Classe D Class D	Classe E Class E	Classe F Class F
0,1	27,0	40,0	N/A	N/A	N/A	N/A
1,0	N/A	25,0	39,1	60,0	65,0	65,0
16,0	N/A	N/A	19,4	43,6	53,2	65,0
100,0	N/A	N/A	N/A	30,1	39,9	62,9
250,0	N/A	N/A	N/A	N/A	33,1	56,9
600,0	N/A	N/A	N/A	N/A	N/A	51,2

Channel PSNEXT

Frequenza <i>Frequency</i> MHz	PSNEXT minimo <i>Minimum PSNEXT</i> dB		
	Classe D <i>Class D</i>	Classe E <i>Class E</i>	Classe F <i>Class F</i>
0,1	N/A	N/A	N/A
1,0	57,0	62,0	62,0
16,0	40,6	50,6	62,0
100,0	27,1	37,1	59,9
250,0	N/A	30,2	53,9
600,0	N/A	N/A	48,2

Channel ACR

Frequenza Frequency MHz	ACR minimo Minimum ACR dB		
	Classe D Class D	Classe E Class E	Classe F Class F
0,1	N/A	N/A	N/A
1,0	56,0	61,0	61,0
16,0	34,5	44,9	56,9
100,0	6,1	18,2	42,1
250,0	N/A	-2,8	23,1
600,0	N/A	N/A	-3,4

Channel PSACR

Frequenza Frequency MHz	PSACR minimo Minimum PSACR dB		
	Classe D Class D	Classe E Class E	Classe F Class F
0,1	N/A	N/A	N/A
1,0	53,0	58,0	58,0
16,0	31,5	42,3	53,9
100,0	3,1	15,4	39,1
250,0	N/A	-5,8	20,1
600,0	N/A	N/A	-6,4

Channel Return Loss

Frequenza Frequency MHz	Perdita di ritorno minima Minimum return loss dB			
	Classe C Class C	Classe D Class D	Classe E Class E	Classe F Class F
1,0	15,0	17,0	19,0	19,0
16,0	15,0	17,0	18,0	18,0
100,0	N/A	10,0	12,0	12,0
250,0	N/A	N/A	8,0	8,0
600,0	N/A	N/A	N/A	8,0

Channel ELFEXT

Frequenza <i>Frequency</i> MHz	ELFEXT minimo <i>Minimum ELFEXT</i> dB		
	Classe D <i>Class D</i>	Classe E <i>Class E</i>	Classe F <i>Class F</i>
0,1	N/A	N/A	N/A
1,0	57,4	63,3	65,0
16,0	33,3	39,2	57,5
100,0	17,4	23,3	44,4
250,0	N/A	15,3	37,8
600,0	N/A	N/A	31,3

Channel PSELFEXT

Frequenza <i>Frequency</i> MHz	PSELFEXT minimo <i>Minimum PSELFEXT</i> dB		
	Classe D <i>Class D</i>	Classe E <i>Class E</i>	Classe F <i>Class F</i>
0,1	N/A	N/A	N/A
1,0	54,4	60,3	62,0
16,0	30,3	36,2	54,5
100,0	14,4	20,3	41,4
250,0	N/A	12,3	34,8
600,0	N/A	N/A	28,3

Permanent Link Attenuation

Attenuation limits for a permanent link at key frequencies

Limiti di attenuazione in un collegamento permanente a frequenze definite

Frequenza <i>Frequency</i> MHz	Attenuazione massima <i>Maximum attenuation</i> dB					
	Classe_Class A	Classe_Class B	Classe_Class C	Classe_Class D	Classe_Class E	Classe_Class F
0,1	16,0	5,5	N/A	N/A	N/A	N/A
1,0	N/A	5,8	4,0	4,0	4,0	4,0
16,0	N/A	N/A	12,2	7,7	7,1	6,9
100,0	N/A	N/A	N/A	20,4	18,5	17,7
250,0	N/A	N/A	N/A	N/A	30,7	28,8
600,0	N/A	N/A	N/A	N/A	N/A	46,6

Permanent Link NEXT

Frequenza <i>Frequency</i> MHz	NEXT minima <i>Minimum NEXT</i> dB					
	Classe A <i>Class A</i>	Classe B <i>Class B</i>	Classe C <i>Class C</i>	Classe D <i>Class D</i>	Classe E <i>Class E</i>	Classe F <i>Class F</i>
0,1	27,0	40,0	N/A	N/A	N/A	N/A
1,0	N/A	25,0	40,1	60,0	65,0	65,0
16,0	N/A	N/A	21,1	45,2	54,6	65,0
100,0	N/A	N/A	N/A	32,3	41,8	65,0
250,0	N/A	N/A	N/A	N/A	35,3	60,4
600,0	N/A	N/A	N/A	N/A	N/A	54,7

Permanent Link PSNEXT

Frequenza <i>Frequency</i> MHz	PSNEXT minimo <i>Minimum PSNEXT</i> dB		
	Classe D <i>Class D</i>	Classe E <i>Class E</i>	Classe F <i>Class F</i>
1,0	57,0	62,0	62,0
16,0	42,2	52,2	62,0
100,0	29,3	39,3	62,0
250,0	N/A	32,7	57,4
600,0	N/A	N/A	51,7

Permanent Link ACR

Frequenza Frequency MHz	ACR minimo Minimum ACR dB		
	Classe D Class D	Classe E Class E	Classe F Class F
1,0	56,0	61,0	61,0
16,0	37,5	47,5	58,1
100,0	11,9	23,3	47,3
250,0	N/A	4,7	31,6
600,0	N/A	N/A	8,1

Permanent Link PSACR

Frequenza Frequency MHz	PSACR minimo Minimum PSACR dB		
	Classe D Class D	Classe E Class E	Classe F Class F
1,0	53,0	58,0	58,0
16,0	34,5	45,1	55,1
100,0	8,9	20,8	44,3
250,0	N/A	2,0	28,6
600,0	N/A	N/A	5,1

Permanent Link Return Loss

Frequenza <i>Frequency</i> MHz	Perdita di ritorno minima <i>Minimum return loss</i> dB			
	Classe C <i>Class C</i>	Classe D <i>Class D</i>	Classe E <i>Class E</i>	Classe F <i>Class F</i>
1,0	15,0	19,0	21,0	21,0
16,0	15,0	19,0	20,0	20,0
100,0	N/A	12,0	14,0	14,0
250,0	N/A	N/A	10,0	10,0
600,0	N/A	N/A	N/A	10,0

Permanent Link ELFEXT

Frequenza <i>Frequency</i> MHz	ELFEXT minimo <i>Minimum ELFEXT</i> dB		
	Classe D <i>Class D</i>	Classe E <i>Class E</i>	Classe F <i>Class F</i>
1,0	58,6	64,2	65,0
16,0	34,5	40,1	59,3
100,0	18,6	24,2	46,0
250,0	N/A	16,2	39,2
600,0	N/A	N/A	32,6

Permanent Link PSELFEXT

Frequenza <i>Frequency</i> MHz	PSELFEXT minimo <i>Minimum PSELFEXT</i> dB		
	Classe D <i>Class D</i>	Classe E <i>Class E</i>	Classe F <i>Class F</i>
1,0	55,6	61,2	62,0
16,0	31,5	37,1	56,3
100,0	15,6	21,2	43,0
250,0	N/A	13,2	36,2
600,0	N/A	N/A	29,6

Backwards compatibility matrix

- Backward compatibility means that mated connections with plugs and sockets from different categories shall meet all requirements for the lower category component.

Spina/cordone modulare <i>Modular plug/cord</i>	Categoria del connettore modulare (T0) <i>Modular connector (T0) Category</i>		
	Categoria 5 <i>Category 5</i>	Categoria 6 <i>Category 6</i>	Categoria 7 <i>Category 7</i>
Categoria 5 <i>Category 5</i>	Categoria 5 <i>Category 5</i>	Categoria 5 <i>Category 5</i>	Categoria 5 <i>Category 5</i>
Categoria 6 <i>Category 6</i>	Categoria 5 <i>Category 5</i>	Categoria 6 <i>Category 6</i>	Categoria 6 <i>Category 6</i>
Categoria 7 <i>Category 7</i>	Categoria 5 <i>Category 5</i>	Categoria 6 <i>Category 6</i>	Categoria 7 <i>Category 7</i>

Multimode optical fiber cable specifications

- The optical fibre shall be multimode, graded-index optical fibre waveguide with nominal 50/125 μm or 62,5/125 μm core/cladding diameter complying with A1a or A1b optical fibre, respectively, of EN 60793-2-10:2002.

Category	Maximum attenuation dB/Km		Minimum modal bandwidth MHz x Km		
			Overfilled launch		Effective Laser Launch
	850 nm	1300 nm	850 nm	1300 nm	
OM1	3,5	1,5	200	500	not specified
OM2	3,5	1,5	500	500	not specified
OM3	3,5	1,5	1500	500	2000

Note: OM3 can only be realized with 50/125 μm fibres.

Singlemode optical fibre cable (Category OS1) performance requirements

- The optical fibre shall comply with B1 fibre of EN 60793-2-50:2002.
- The cut-off wavelength of singlemode optical fibre cables shall be less than 1260 nm when measured in accordance with EN 60793-1-44.
- The mechanical and environmental requirements for indoor and outdoor optical fibre cables are defined in accordance with EN 60794-1-1, EN 60794-1-2, IEC 60794-2 and EN 60794-3.

<i>Wavelength</i> nm	<i>Maximum attenuation</i> dB/km
1310	1,0
1550	1,0

Backbone cabling design

- Backbone cables can be:
 - Balanced copper cables
 - Fiber optic cables
- Maximum distance depending by:
 - Cable characteristics
 - Applications and connection Classes

Backbone cabling model

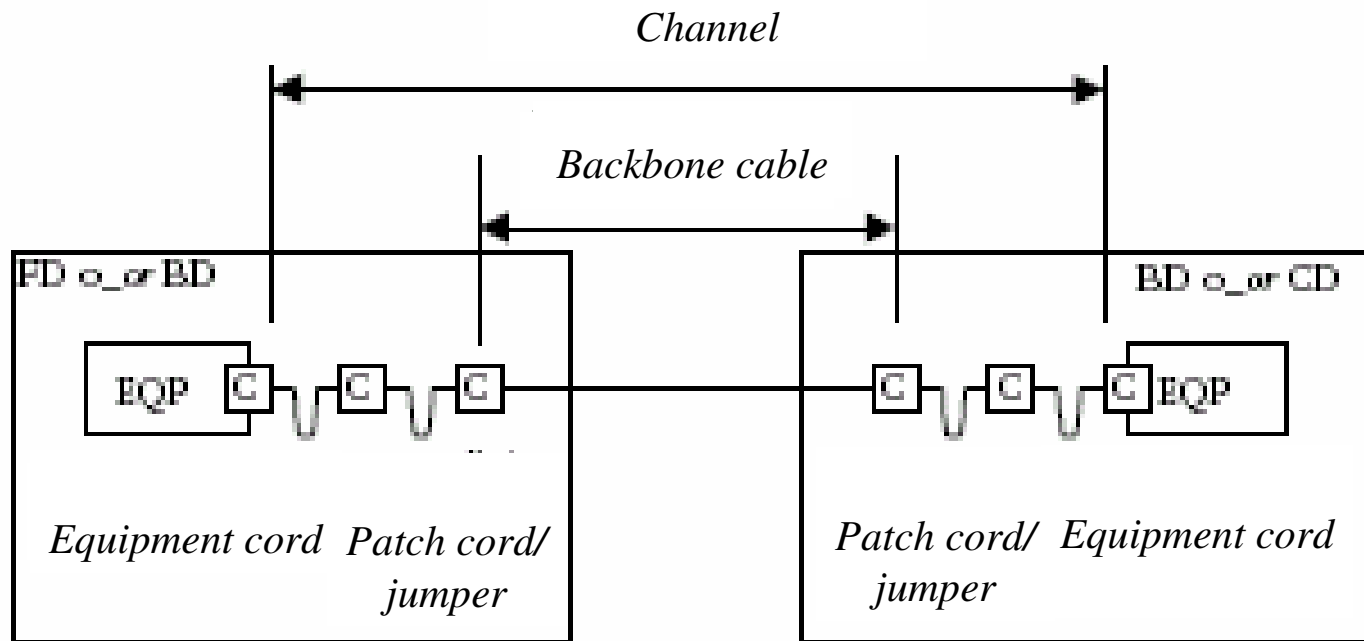

Backbone channel equations

Component Category	Class ^(a)					
	A	B	C	D	E	F
5	2000	$B = 250 - F \times X$	$B = 170 - F \times X$	$B = 105 - F \times X$	—	—
6	2000	$B = 260 - F \times X$	$B = 185 - F \times X$	$B = 111 - F \times X$	$B = 105 - 3^{(b)} - F \times X$	
7	2000	$B = 260 - F \times X$	$B = 190 - F \times X$	$B = 115 - F \times X$	$B = 107 - 3^{(b)} - F \times X$	$B = 105 - 3^{(b)} - F \times X$
<p><i>B</i> Length of the fixed backbone cable (m)</p> <p><i>F</i> Combined length of patch cords, jumpers and equipment cords (m).</p> <p><i>X</i> Ratio of flexible cable attenuation (dB/m) to fixed backbone cable attenuation (dB/m).</p>						
<p>(a) Applications limited by propagation delay or skew may not be supported if channel lengths exceed 100 m.</p> <p>(b) This length reduction is to provide an allocated margin to accommodate insertion loss deviation..</p>						
<p>Where channels contain a different number of connections than in the model shown in Figure 8, the fixed cable length shall be reduced (where more connections exist) or may be increased (where fewer connections exist) by 2 m per connection for Category 5 cabling and 1 m per connection for Category 6 and 7 components. Additionally, the NEXT, Return Loss and ELFEXT performance should be verified.</p>						
<p>For operating temperatures above 20 °C, B should be reduced by 0,2% per °C for screened cables and 0,4 % per °C (20 °C to 40 °C) and 0,6% per °C (> 40 °C to 60 °C) for unscreened cables.</p>						

Optical fibre channel lengths

- When fiber optic is used in the Campus and Building backbone up to work area (horizontal cabling) it is possible to consider a combined campus/building/horizontal channel.
- Combined backbone/horizontal channels:
 - "Patched" combined channel
 - "Spliced" combined channel
 - "Direct" combined channel

"Patched" combined channel

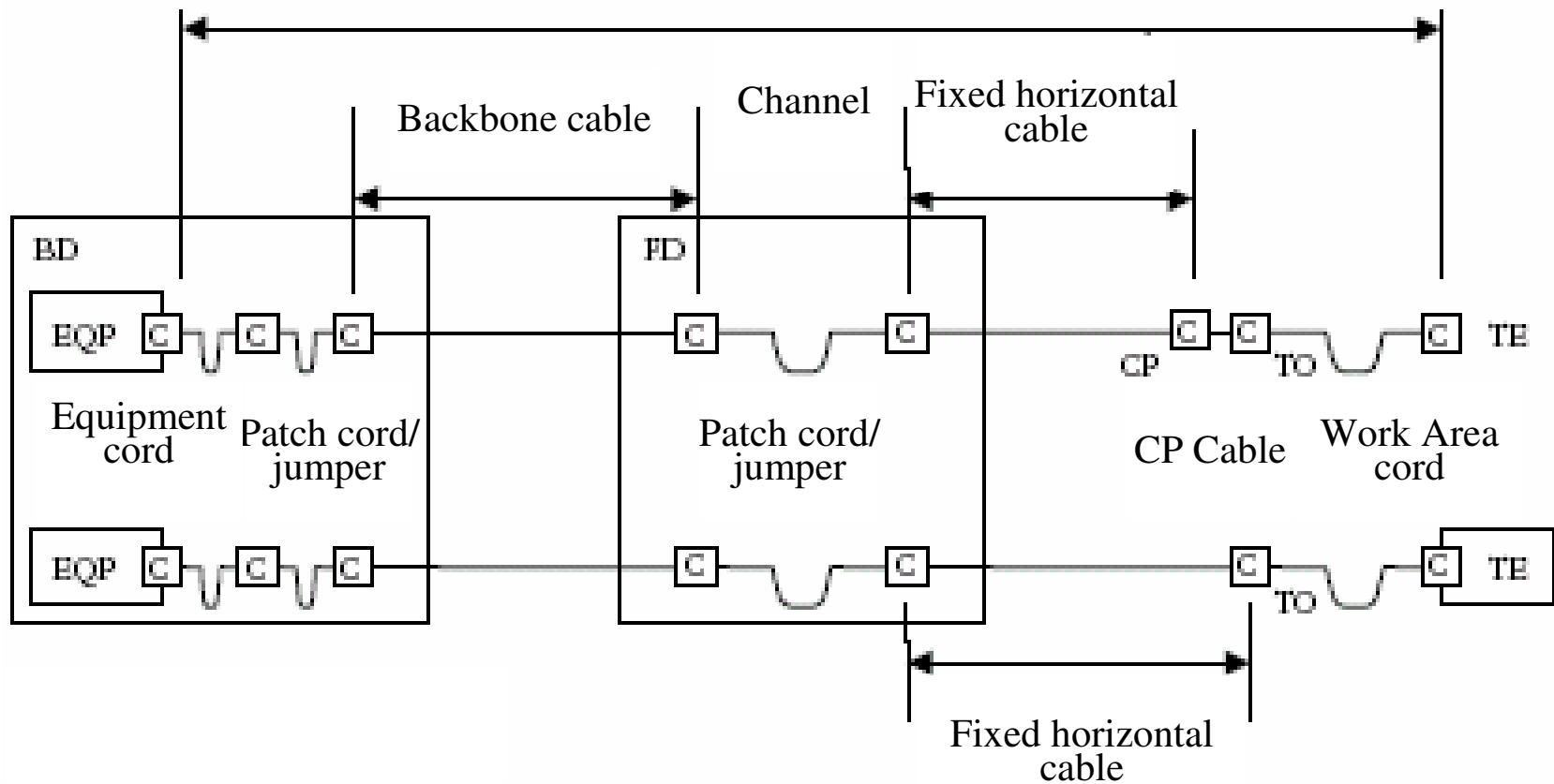

"Spliced" combined channel

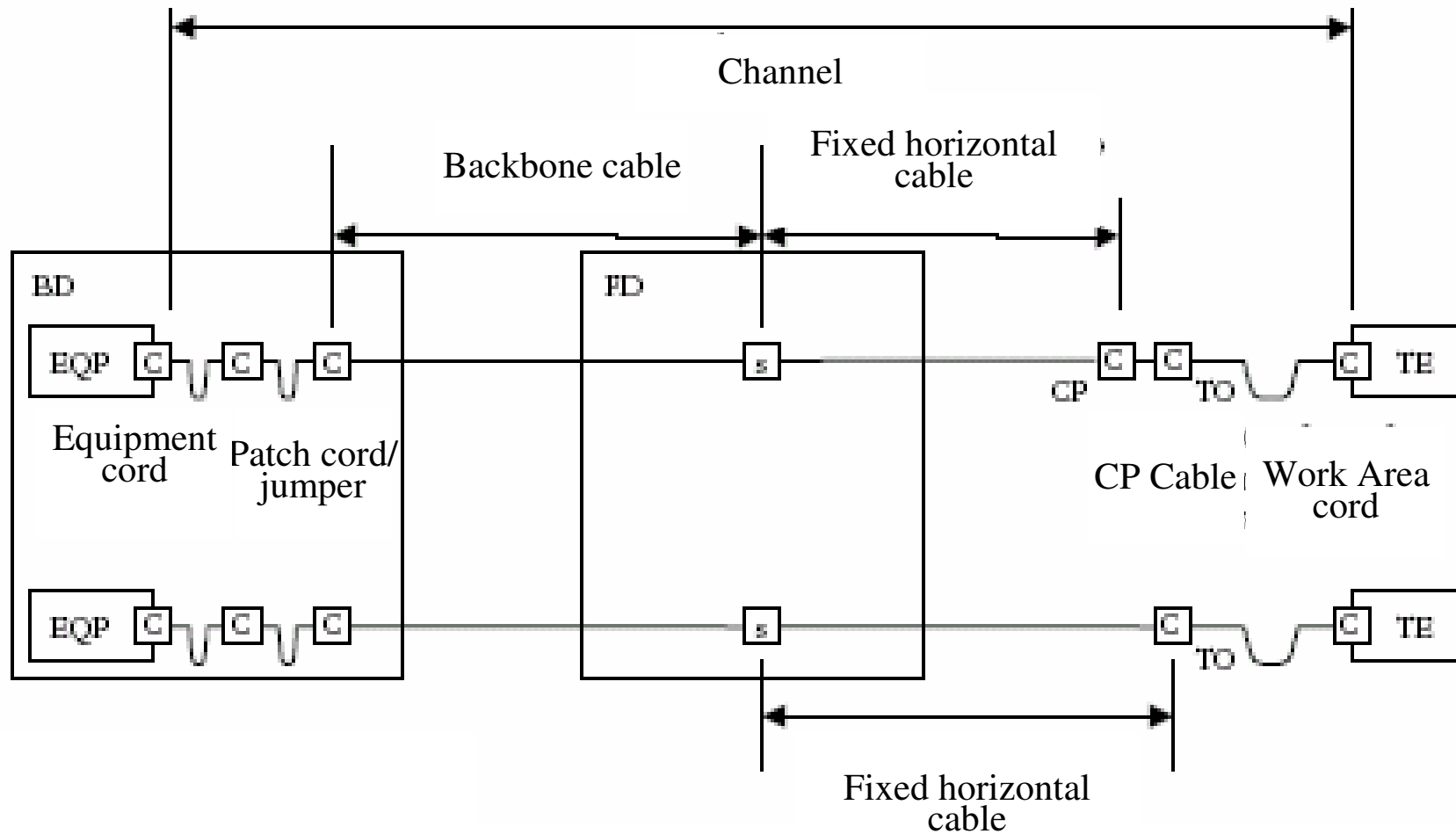

"Direct" combined channel

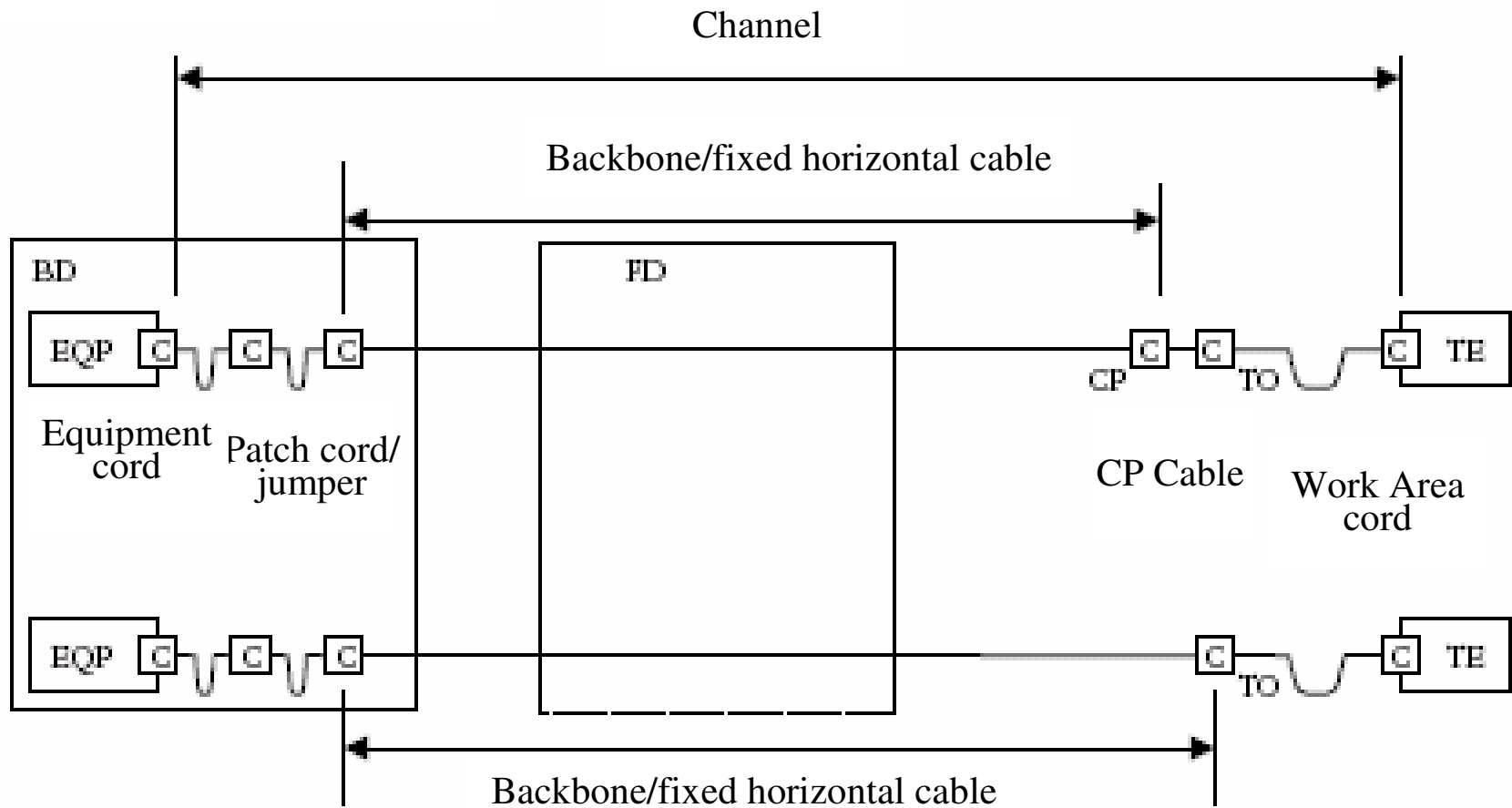

Optical fibre channel parameters

Optical fiber type	Class	Implementation equations ^(a)		Maximum length m
Multimode		850 nm	1300 nm	
Cable Category OM1/OM2/OM3	OF-300	$L = 735 - 145 \times X - 90 \times Y$	$L = 1300 - 330 \times X - 200 \times Y$	300
	OF-500	$L = 935 - 145 \times X - 90 \times Y$	$L = 1500 - 330 \times X - 200 \times Y$	500
	OF-2000	$L = 2435 - 145 \times X - 90 \times Y$	$L = 3000 - 330 \times X - 200 \times Y$	2000
Singlemode		1310 nm	1550 nm	
OS1	OF-300	$L = 1800 - 500 \times X - 300 \times Y$	$L = 1800 - 500 \times X - 300 \times Y$	300
	OF-500	$L = 2000 - 500 \times X - 300 \times Y$	$L = 2000 - 500 \times X - 300 \times Y$	500
	OF-2000	$L = 3500 - 500 \times X - 300 \times Y$	$L = 3500 - 500 \times X - 300 \times Y$	2000
<p><i>L</i> Length of the channel (m) <i>X</i> Total number of mated connections in the channel (m) <i>Y</i> Total number of splices in the channel.</p>				
<p>(a) These equations assume 0,5 dB attenuation per mated connection (as for a two connection system only 0,25 % would exceed that value)</p>				

Optical fibre connecting hardware

- Telecommunications outlet requirements
 - The optical fibre cables in the work area shall be connected to the horizontal cabling with a duplex SC connector (SC-D) which meets the requirements of detail specification IEC 60874-19-1.
- Marking and colour coding
 - The following colour code applies for IEC 60874-19-1 SC Duplex connectors:
 - Multimode: **beige or black**
 - Singlemode (physical contact): **blue**
 - Singlemode (angled physical contact): **green**

Mechanical and optical characteristics of optical fibre connecting hardware

- Optical performance characteristics
 - Connectors maximum attenuation:
 - 0,5 dB for 95% of matings
 - 0,75 dB for 100% of matings
 - Splice maximum attenuation 0,3 dB
 - Minimum return loss:
 - Multimode 20 dB
 - Siglemode 35 dB

ELECTROMAGNETIC CHARACTERISTICS

- Cabling consists of passive components and can therefore only be verified for conformance with EN 55022 and EN 55024 together with attached application-specific equipment.
- Electromagnetic characteristics of a network installation are influenced by parameters, which characterise the balance and/or screening properties of the cabling.