



Wireless LAN: Indoor, Hot Spot & Outdoor design

Pietro Nicoletti
piero[at]studioreti.it



Copyright note

This set of transparencies, hereinafter referred to as slides, is protected by copyright laws and provisions of International Treaties. The title and copyright regarding the slides (including, but not limited to, each and every image, photography, animation, video, audio, music and text) are property of the authors specified on page 1.

The slides may be reproduced and used freely by research institutes, schools and Universities for non-profit, institutional purposes. In such cases, no authorization is requested.

Any total or partial use or reproduction (including, but not limited to, reproduction on magnetic media, computer networks, and printed reproduction) is forbidden, unless explicitly authorized by the authors by means of written license.

Information included in these slides is deemed as accurate at the date of publication. Such information is supplied for merely educational purposes and may not be used in designing systems, products, networks, etc. In any case, these slides are subject to changes without any previous notice. The authors do not assume any responsibility for the contents of these slides (including, but not limited to, accuracy, completeness, enforceability, updated-ness of information hereinafter provided).

In any case, accordance with information hereinafter included must not be declared.

In any case, this copyright notice must never be removed and must be reported even in partial uses.



Wireless LAN implementations

- Indoor Wireless LAN:
 - Cover an area inside the building

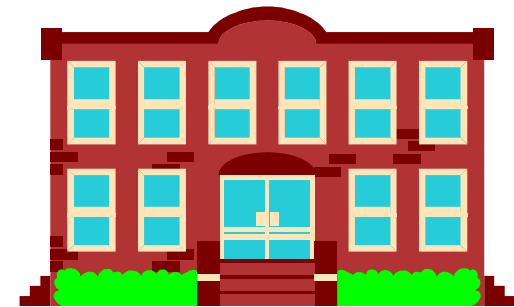

- Outdoor Wireless LAN:
 - Connect Building LANs across wireless medium

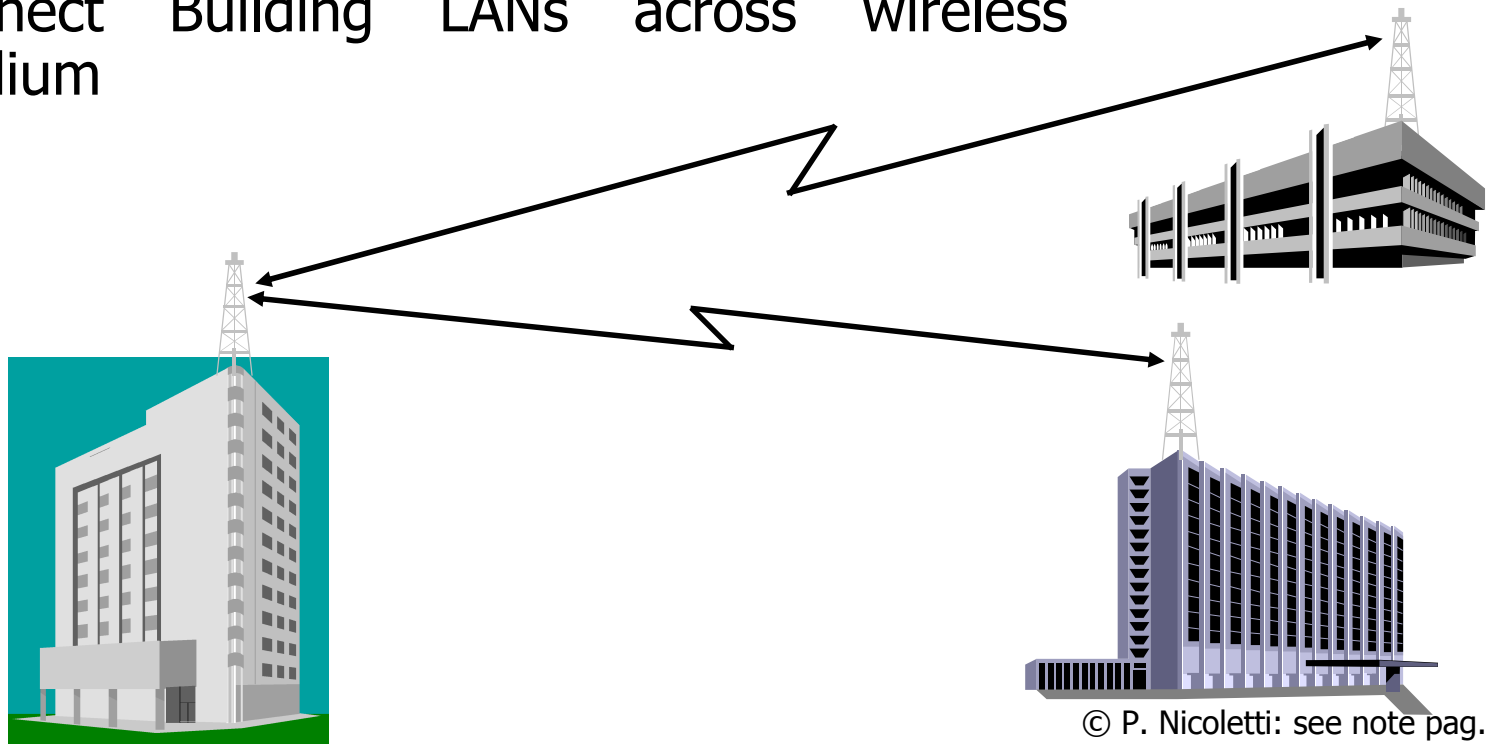



Wireless LAN implementations

■ HOT SPOT

- Cover a public limited internal or external area where the people can access to Internet services via Wireless LAN

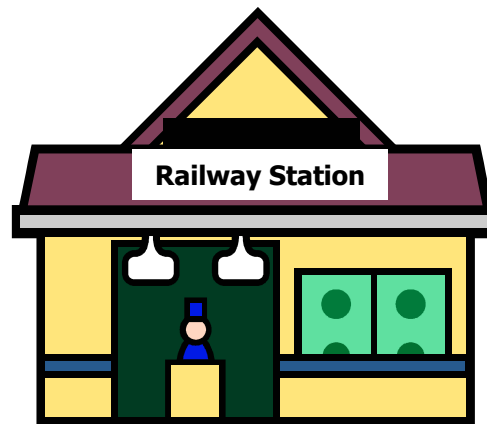



Wireless Indoor networks: features and problems

- They cover a limited area like:
 - meeting room
 - flat or office home
 - area with architectural constraints
 - office area as complement to the wired network
 - store
- Design problems:
 - cell coverage and performances
 - security and privacy
 - users' access
 - DSSS Access Point interference



Wireless-LAN IN-DOOR 802.11b: approximate radio covering ray in Europe

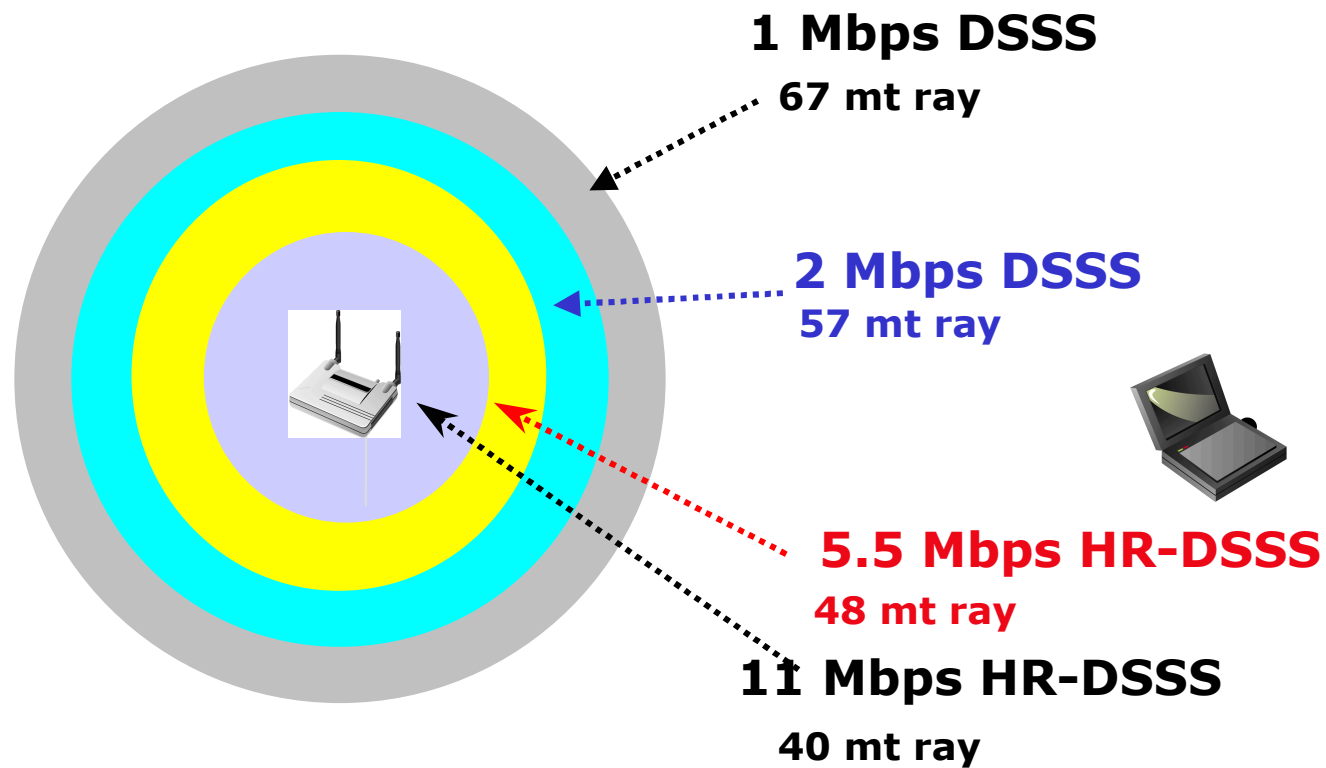



Wireless-LAN: Automatic Rate Fallback

- Lowest Data rate are characterized by a more robust communication with longer distance coverage with respect to higher data rate
- Station try to work at the maximum speed
- The station in the inner cell area most internal operate at the maximum speed, while that in outer cell area operate at the minimum speed
- The ARF algorithm (Automatic Rate Fallback) allows the station to change automatically date rate as it goes away from the inner cell area
- Mechanism based on the count of lost ACK



IN-DOOR Wireless-LAN: design steps

- The design can be divided into 3 steps:
 - examination of the area to be served and cells planning
 - site survey
 - cell planning reexamination
- At the end of installation could be necessary update the project documentation adding the last modifications



IN-DOOR Wireless-LAN : cell planning and channels assignments

- Having the building plan it is possible to start planning the area covering with several cells, of which a specific channel will be assigned
- Cell overlap
 - fully overlapped to increase the available bandwidth in a determinate area
 - partially overlapped
- Cell overlap typology:
 - horizontal
 - vertical



IN-DOOR Wireless-LAN : Criteria of cell design and their density

- The design of cell covering and of cell population density can be based on:
 - Maximum wireless performances raise in the area to be covered
 - high AP number
 - low area of competence of a cell
 - design which must consider the possible interferences between the cells
 - Big area with the smallest possible AP number
 - low AP number
 - high area competence of a single cell
 - design which must avoid not covered zones
 - performances which change according to the zones



IN-DOOR Wireless-LAN receiver sensitivity: some examples

- Receiver sensitivity must be at least of -76 dBm
 - Average product sensitivities: -84 dBm at 11 Mb/s, -87 dBm at 5,5 Mb/s, -90 dBm at 2 Mb/s, -93 dBm at 1 Mb/s
 - Some Cisco product sensitivities: -85 dBm at 11 Mb/s, -89 dBm at 5,5 Mb/s, -91 dBm at 2 Mb/s, -94 dBm at 1 Mb/s
 - Some Alvarion product sensitivities: -85 dBm at 11 Mb/s, -88 dBm at 5,5 Mb/s, -90 dBm at 2 Mb/s, -93 dBm at 1 Mb/s
 - Some 3COM AP sensitivities: -80 dBm at 11 Mb/s, -84 dBm at 5,5 Mb/s, -85 dBm at 2 Mb/s, -88 dBm at 1 Mb/s
 - Some 3COM NIC sensitivities: -86 dBm at 11 Mb/s, -88 dBm at 5,5 Mb/s, -91 dBm at 2 Mb/s, -93 dBm at 1 Mb/s



IN-DOOR Wireless-LAN: TX-Power

- For the maximum TX-Power the standard refer to the national regulations
 - For the maximum TX-Power the standard refer to the national regulations
 - 32 mW TX-Power is adopted by all manufactures
 - 100 mW (EIRP) TX-Power is adopted by the most manufacturers and is the maximum usable level in Europe
 - Cisco product granularity = 5, 20, 30, 50, 100 mW (7, 13, 15, 17, 20 dBm)
 - Some 3COM cards limit TX-Power at 17 dBm (50 mW)
 - TX-Power of 250 mW is adopted by some Alvarion products and is usable in USA
 - alvarion granularity = -4, -2, 4, 6, 12, 14, 20, 24 dBm



2.4 GHz Transmit Power Level

- USA TX power limit 1000 mW
- Europe TX power limit 100 mW (EIRP)

Maximum output power	Geographic location	Compliance document
1000 mW	USA	FCC 15.247
100 mW (EIRP)	Europe	ETS 300-328
10 mW/MHz	Japan	MPT ordinance for Regulating Radio Equipment, Article 49-20



IN-DOOR Wireless-LAN: reliable ranges according to Path Loss using 100 mW TX-Power

- The receiver sensitivity changes according to data rate
- The maximum distances change according to the environment and data rate
 - The maximum distances shown are referred to an acceptable receiver quality (1 brick wall of 10 cm in the closed offices)

Data Rate	1 Mb/s	2 Mb/s	5,5 Mb/s	11 Mb/s
Receiver sensitivity for BER 10^{-5}	-93 dBm	-90 dBm	-87 dBm	-84 dBm
Range covered 99% point TX Power 20 dBm (100 mW)				
Open plan building	270 mt	198 mt	144 mt	105 mt
Semiopen office	74 mt	59 mt	48 mt	39 mt
Closed office	25 mt	22 mt	19 mt	16 mt



IN-DOOR Wireless-LAN: full horizontal overlap of 3 cells using not-overlapped channels

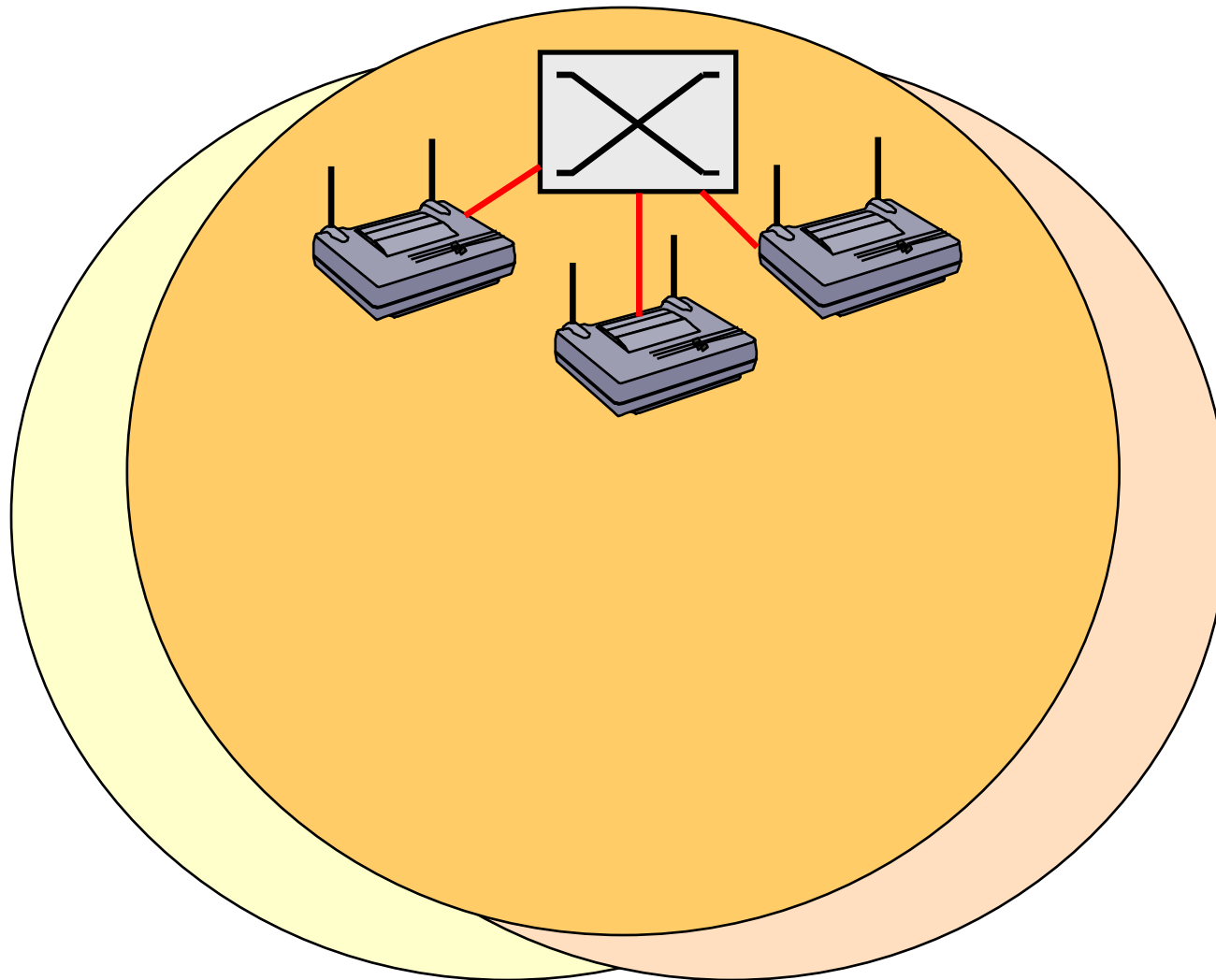



USA: DSSS not overlapped channels

- 3 not overlapped channels may be used on the same cell/area
 - 1, 6, 11
 - 25 MHz spacing

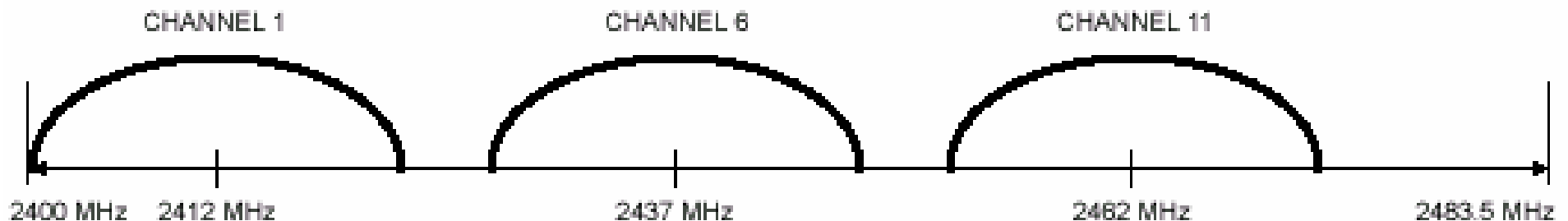



Europe: DSSS not overlapped channels

- 3 not overlapped channels may be used on the same cell/area with 25 or more MHz spacing
 - 1, 7, 13
 - Other possible combinations with 25 MHz spacing
 - 1, 6, 11
 - 2, 7, 12
 - 3, 8, 13

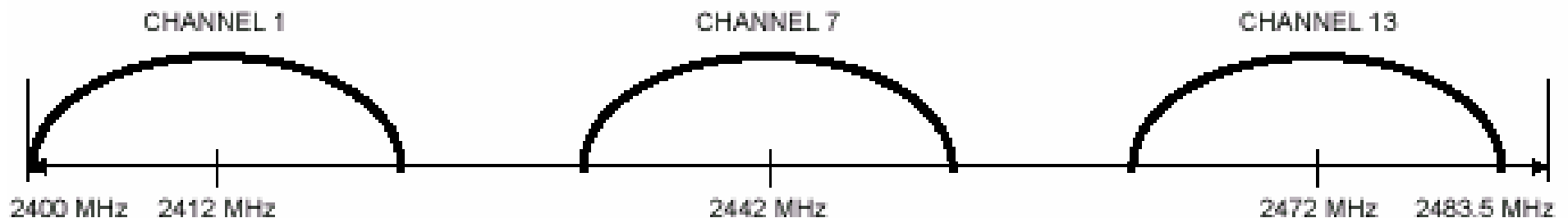



IN-DOOR Wireless-LAN: multi-cell area design

- Establish the axis along which it is necessary to install AP and define the centers cell
- Establish the density cells and their positioning along the defined axis
- Choose an alternative antenna to the one integrated in Access Point in case is not necessary an omni-directional coverage
- Establish the channels to be used in the various cells avoiding the interferences
- Define physical Access Point installation type (wall, roof etc.)



IN-DOOR Wireless-LAN : cells dimensioning on medium open space area

- Area composed by 4 cells in which 2 of these use the same channel
 - use of not-overlapped channels and reuse of one channel

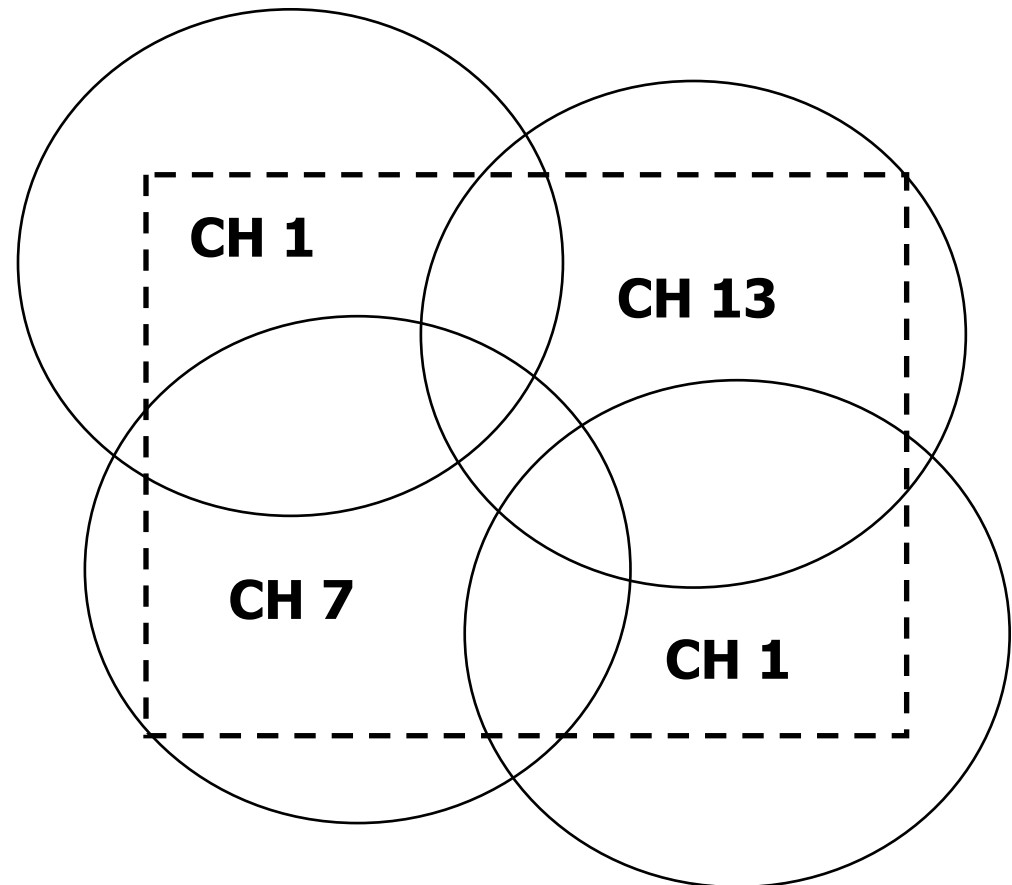



IN-DOOR Wireless-LAN : cells dimensioning on medium open space area

- Asymmetrical type coverage of the area
- Distance between the reused channels
 - low-density model:
 - $d = 100$ m, $d2 = 50$ mt
 - medium-density model:
 - $d1 = 60$ m, $d2 = 30$ mt
 - high-density model:
 - $d1 = 40$ m, $d2 = 20$ mt

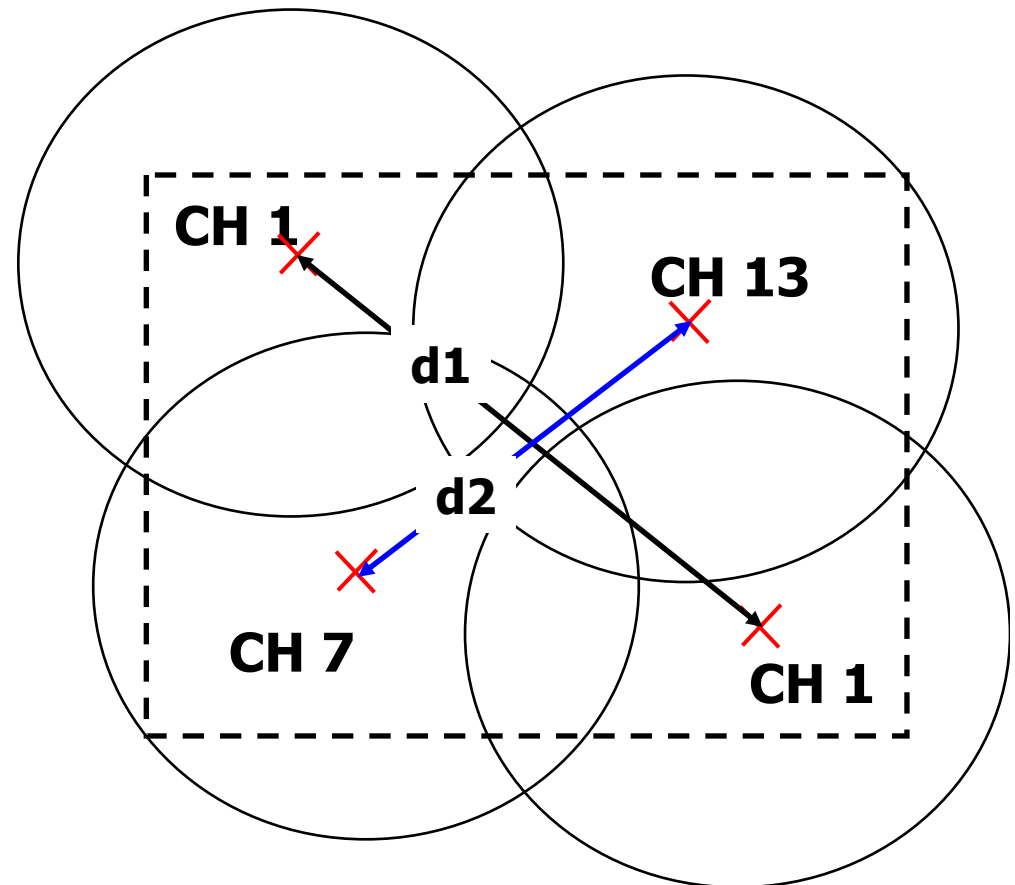



IN-DOOR Wireless-LAN: High-density area Cisco coverage example

- High-density model
 - SNR = 1 or little more at the center of area between the reused channels
- Symmetric type coverage of the area

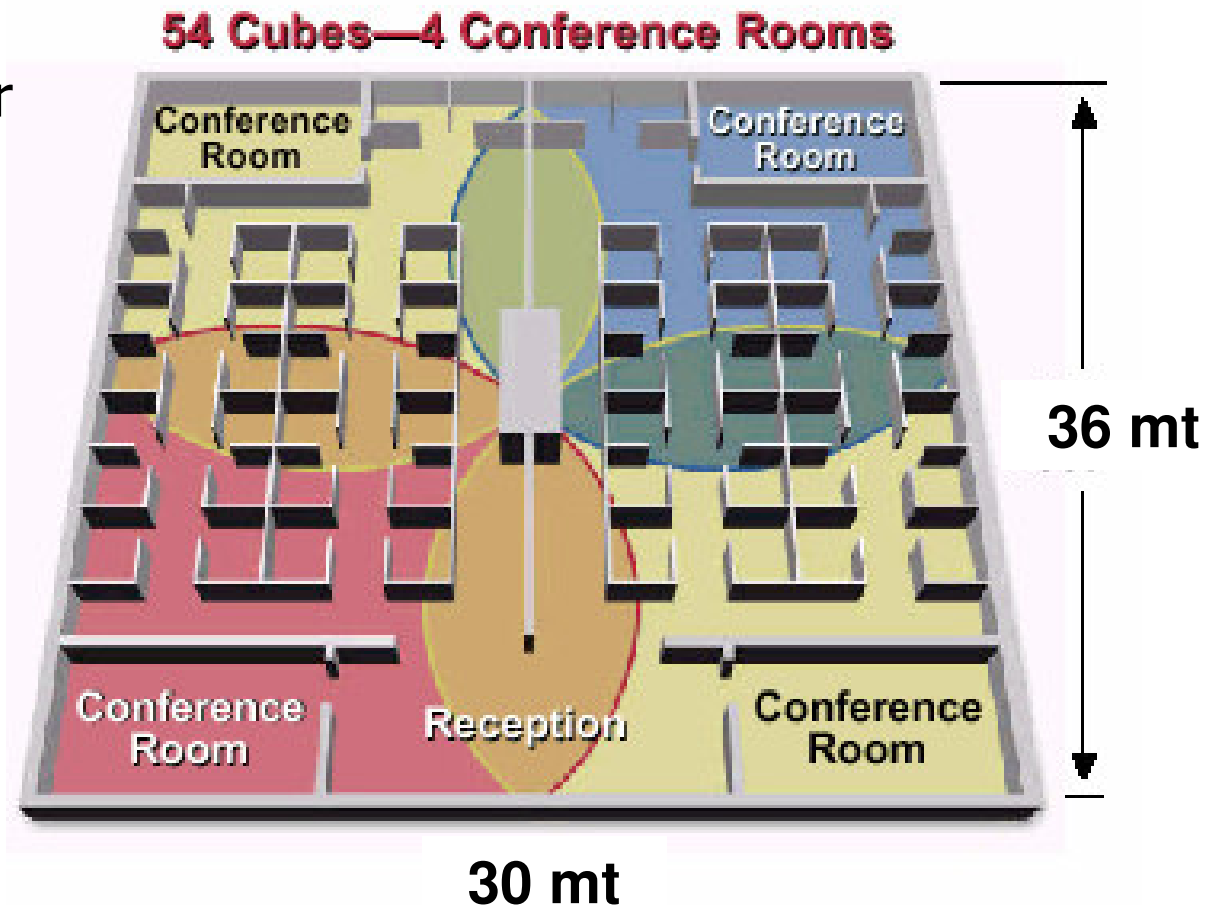



Cisco coverage area example: cell ray calculation

- Axis definition
 - diagonals of the area to be covered
 - a diagonal is the hypotenuse triangle formed by two adjacent sides
 - Hypotenuse
 - Circles ray

$$\text{Hypotenuse} = \sqrt{36^2 + 30^2} = 46,861$$

$$\begin{aligned} \text{Circles ray} &= \text{hypotenuse} / 4 \\ &= 46,861 / 4 = 11,715 \end{aligned}$$

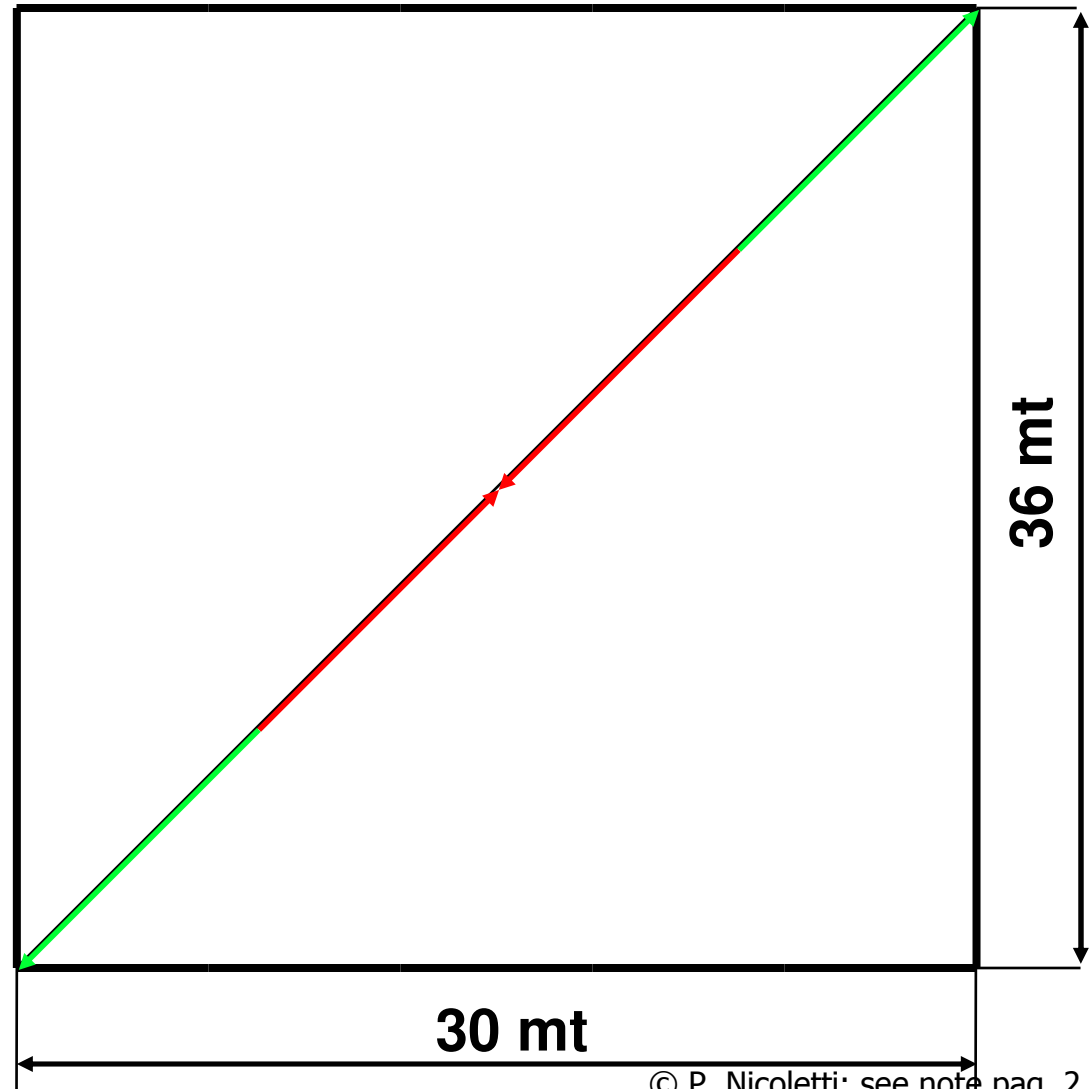



Cisco coverage area example: dimensions and position cells, channel selection

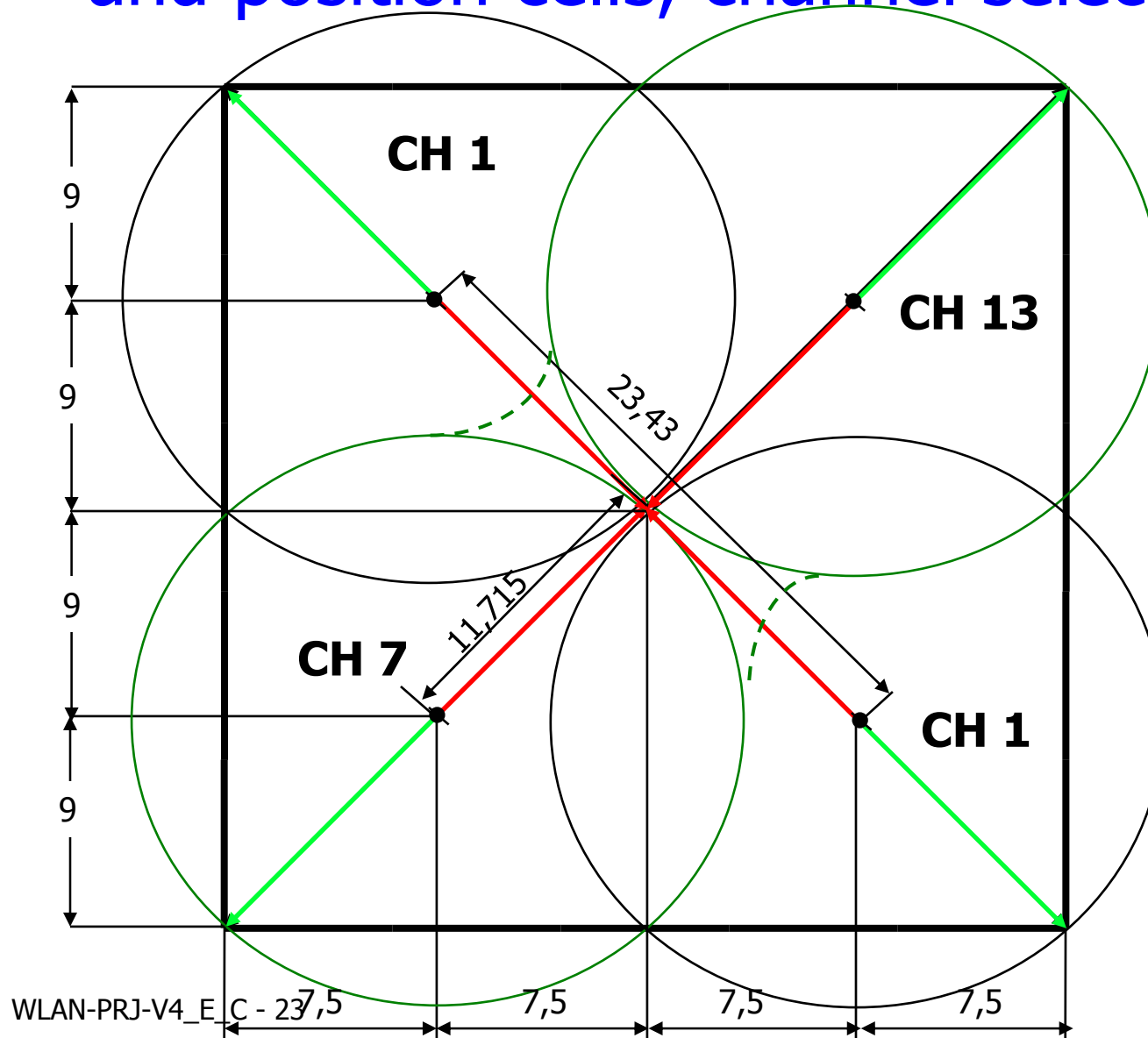

- Symmetric type coverage of the area:
 - cell centers equidistant with respect to the ends of the axis
- Reuse Channel at 23,43 mt
 - channel 1 reused



Alternative to the Cisco example: Reuse Channel at about 30,8 mt

- Lengths and distances

- $I = 46,86 \text{ mt}$, $i1$ & $i2 = 8 \text{ mt}$, $d = 30,86 \text{ mt}$

- Sine calculation of β

$$\sin \beta = c / i$$

$$\sin \beta = 36/46,86$$

$$\sin \beta = 0,768$$

- Cathetus calculation

$$c1 = i1 * \sin \beta$$

$$c1 = 8 * 0,768 = 6,144$$

$$b1 = \sqrt{8^2 - 6,144^2}$$

$$b1 = 5,133$$

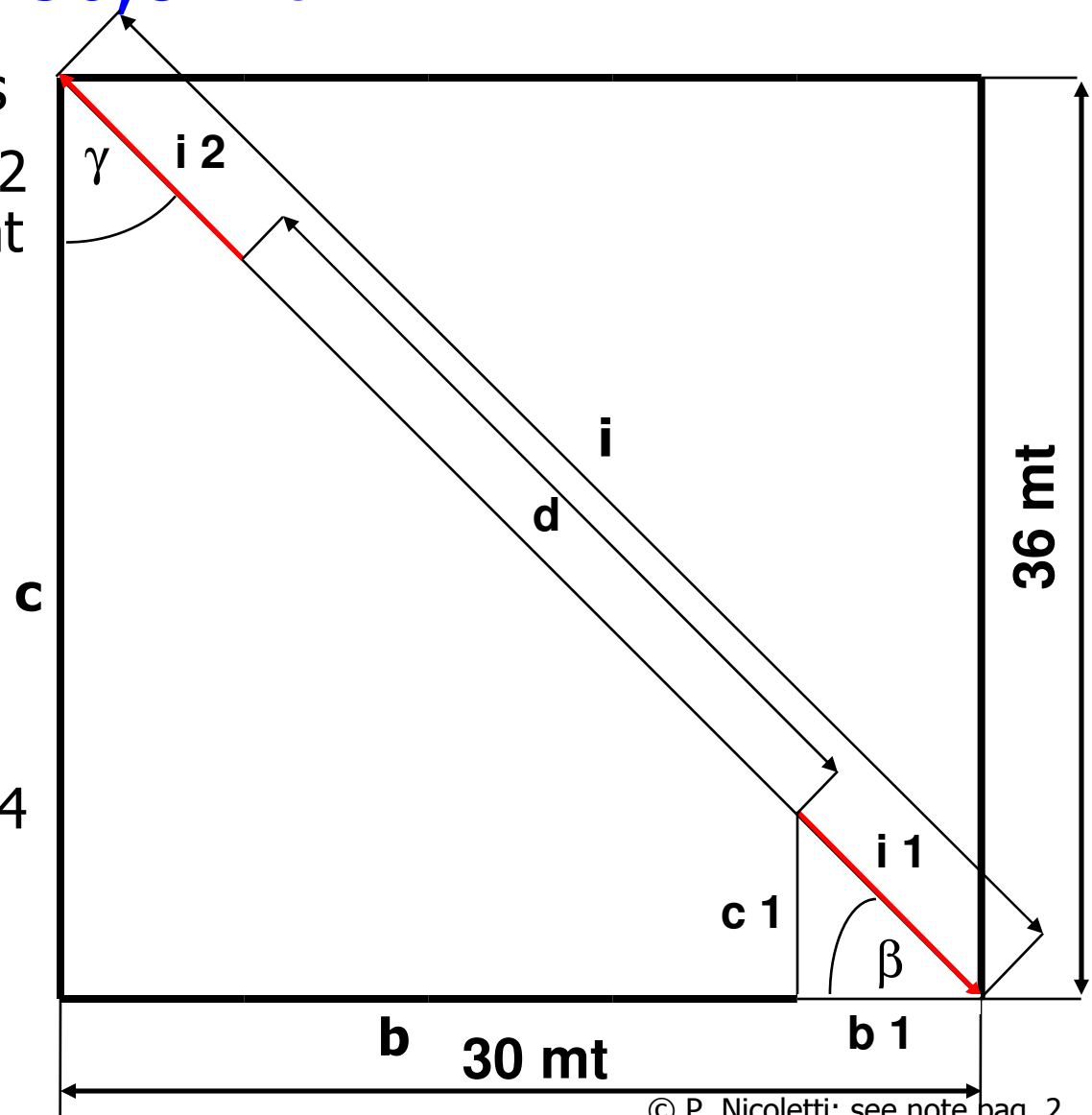



Alternative to the Cisco example: Reuse Channel at about 30,8 mt

- Asymmetrical type coverage of the area

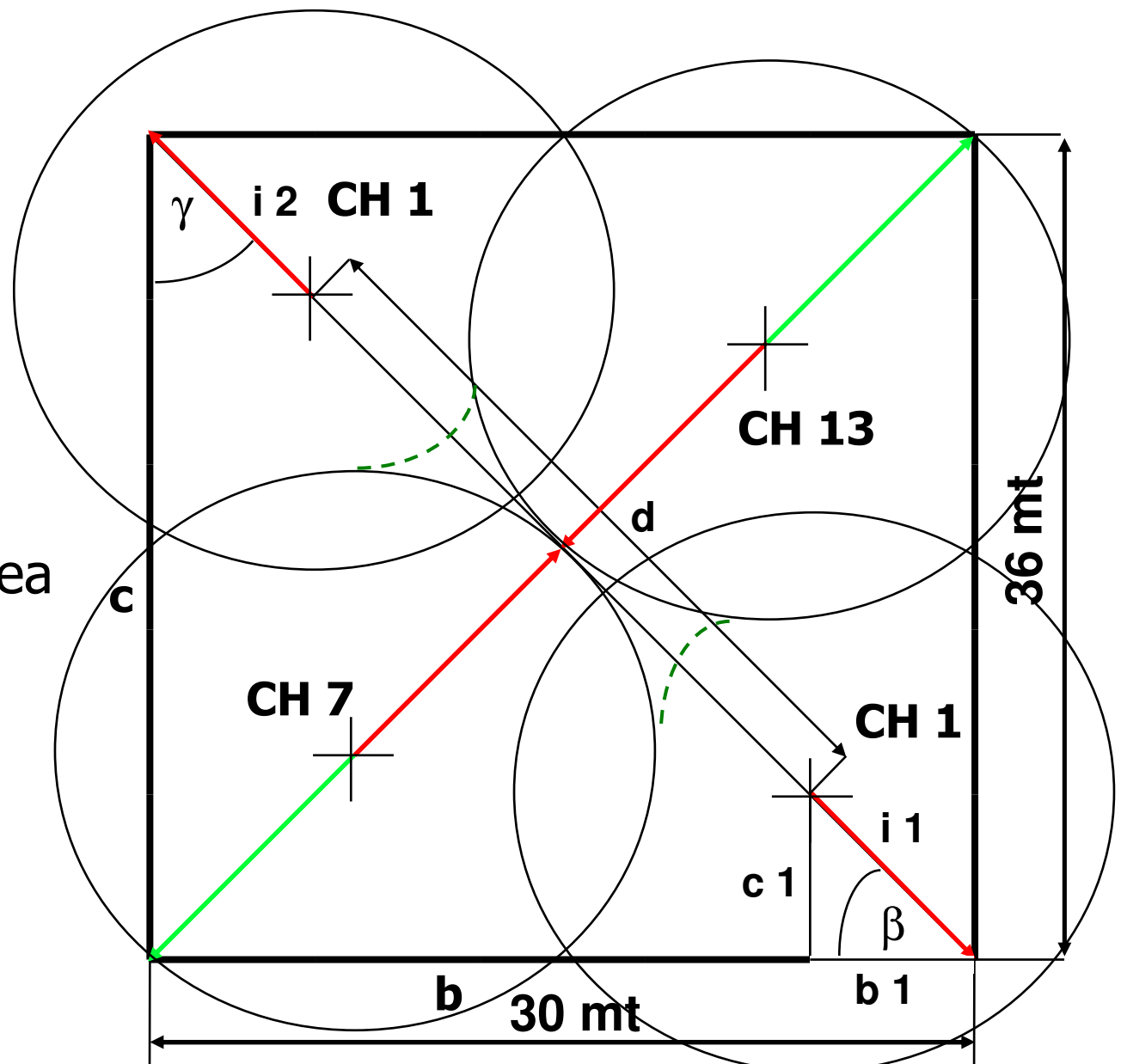



2nd alternative to the Cisco example: 3 cells coverage with 3 not-overlapped channels

- Small/medium dimension areas possible solution
- Choice of the 3 cell centers
 - they must be as much as possible barycentric

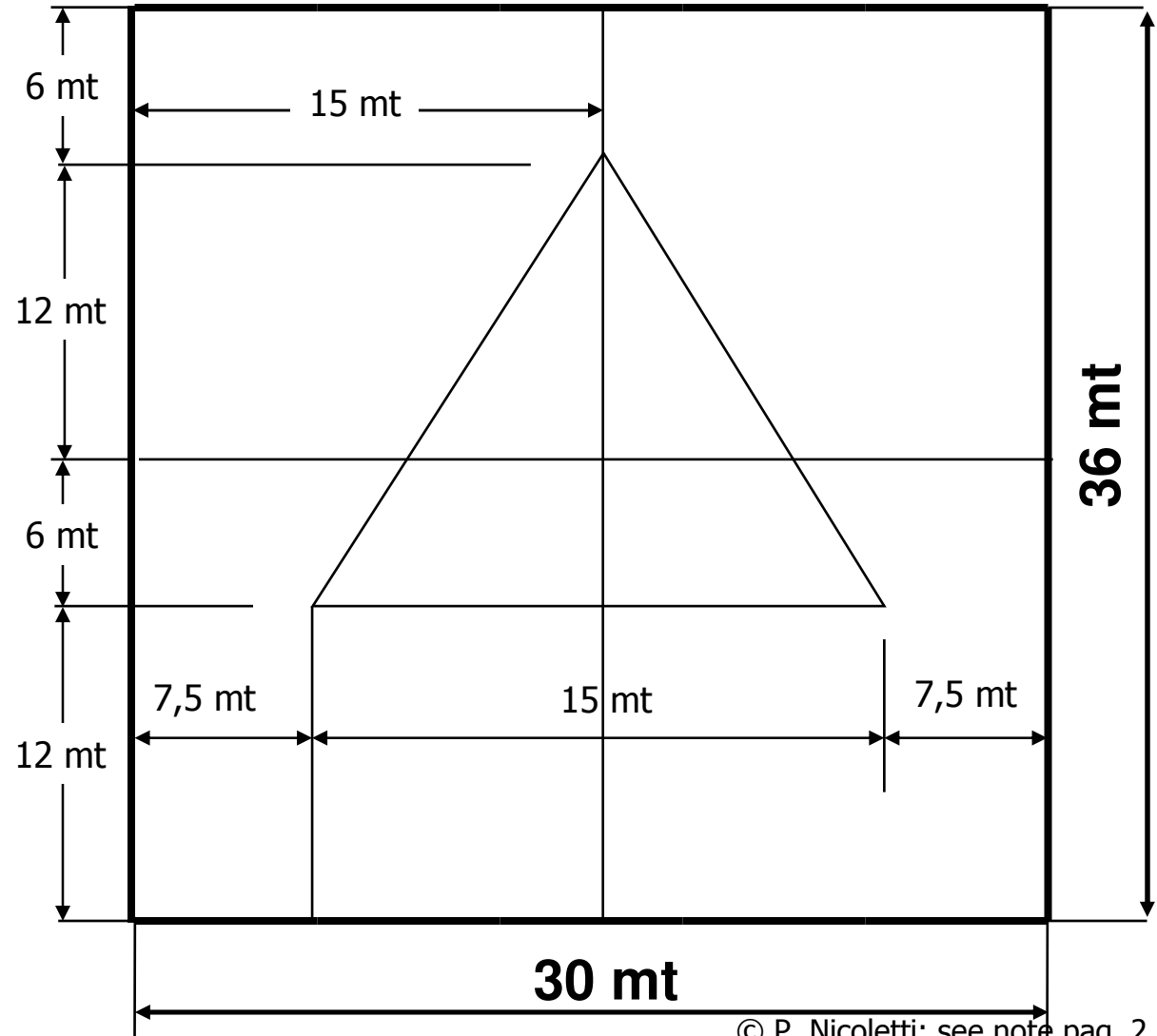

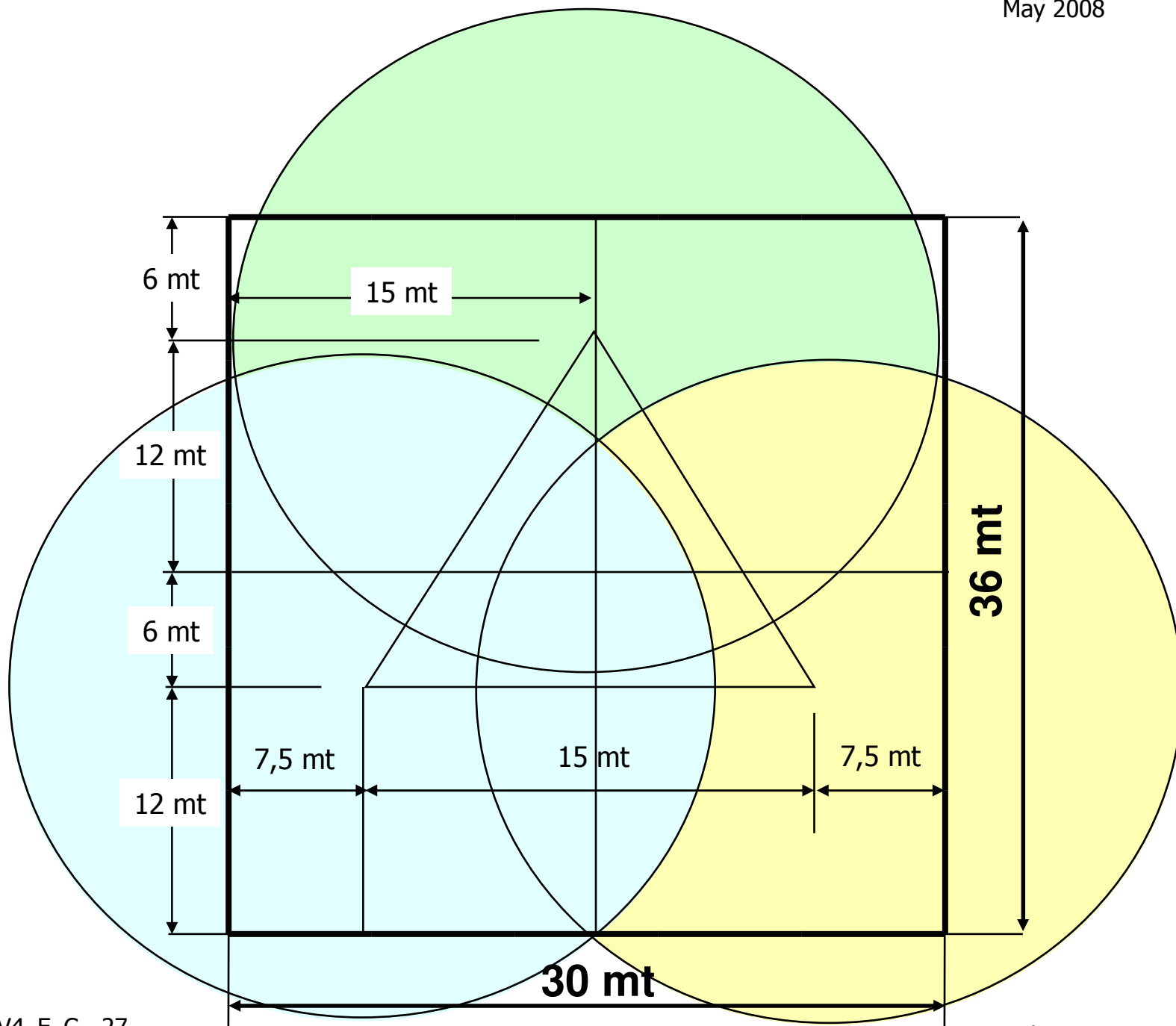



Overlapping channels

- Not overlapped channels
 - Minimum 25 MHz spacing from central frequency
 - May operate in the same cell/area without interference
- Slightly overlapping channels
 - Operate in adjacent cell/areas slightly overlapped;
 - Minimum 15 MHz spacing from central frequency
 - It is necessary to ensure an attenuation of the signal interference from a neighbor cell that want to use the same channel
 - minimum 6 dB over interference signal at 2 Mb/s
 - minimum 12 dB over interference signal at 11 Mb/s



3th alternative to the Cisco example: use of 4 slightly overlapping channels

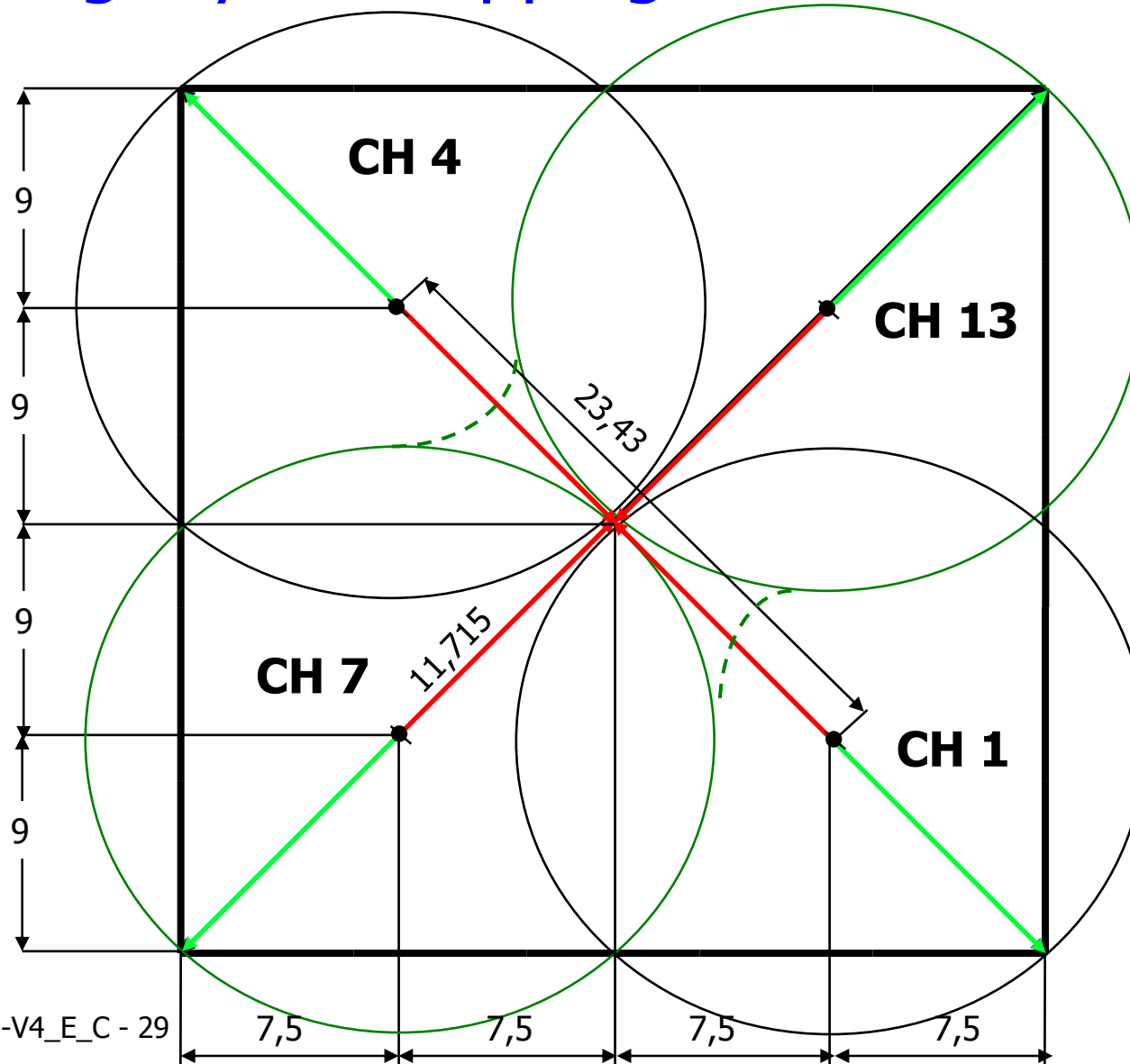



Medium high density area using high density cells with Reuse Channel

- 1st step: Cells coverage planning
- 2nd step: Use a channel with 25 (preferable) or 15 MHz spacing between the adjacent cells using the same channel

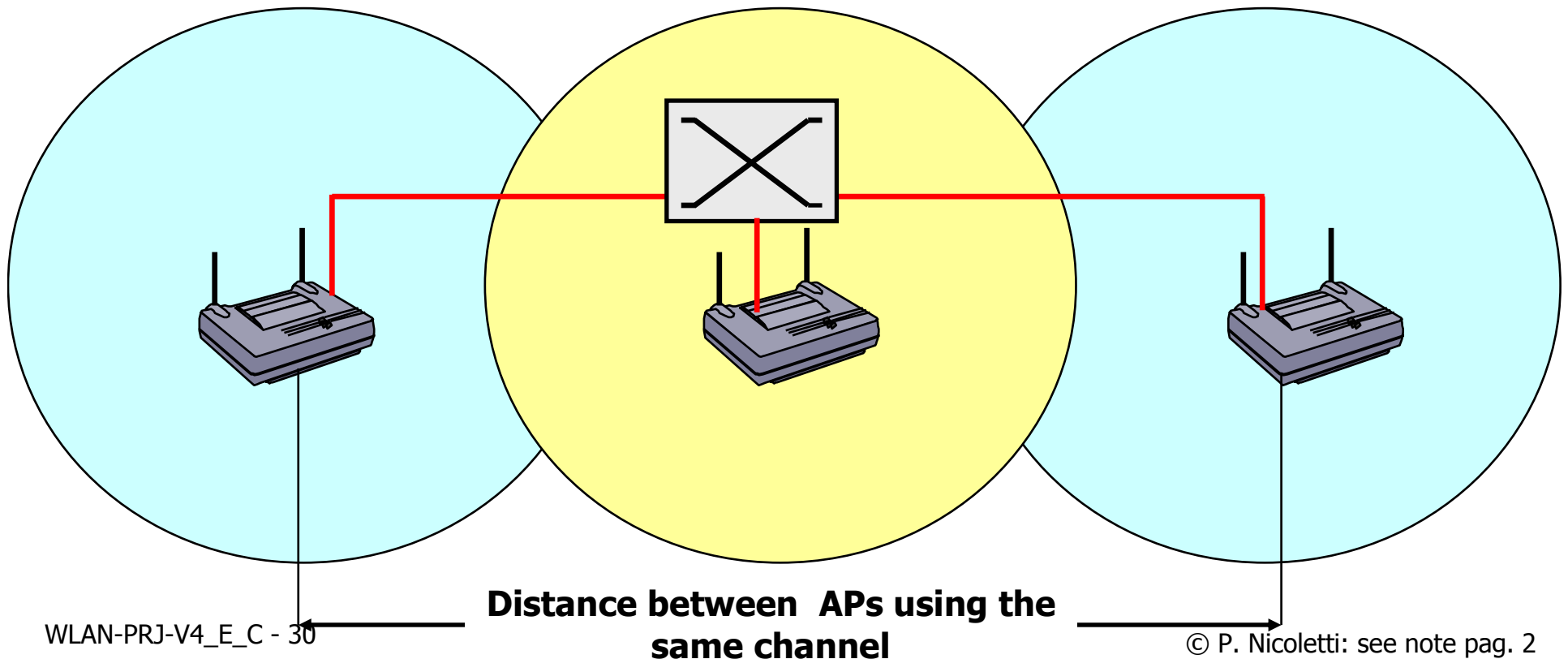



Outdoor area: receiver near AP (-45 dBm)

The screenshot shows a Windows desktop with a 'Site Survey - 350 Series - Passive Mode - [open]' window. The window displays the following information:

Signal Strength	Noise Level
> -45 dBm	-85 dBm
Link Speed: 11 Mbps	Signal to Noise Ratio: 55 dB
Associated Access Point: No Name Specified	Access Point IP Address: 0.0.0.0
Channel (Frequency): 13 (2472 MHz)	

At the bottom of the window, there are buttons for 'Restart Card', 'Setup', 'Start', 'OK', 'Cancel', and 'Help'.



Outdoor area: receiver at 10 mt from AP (-48 dBm)

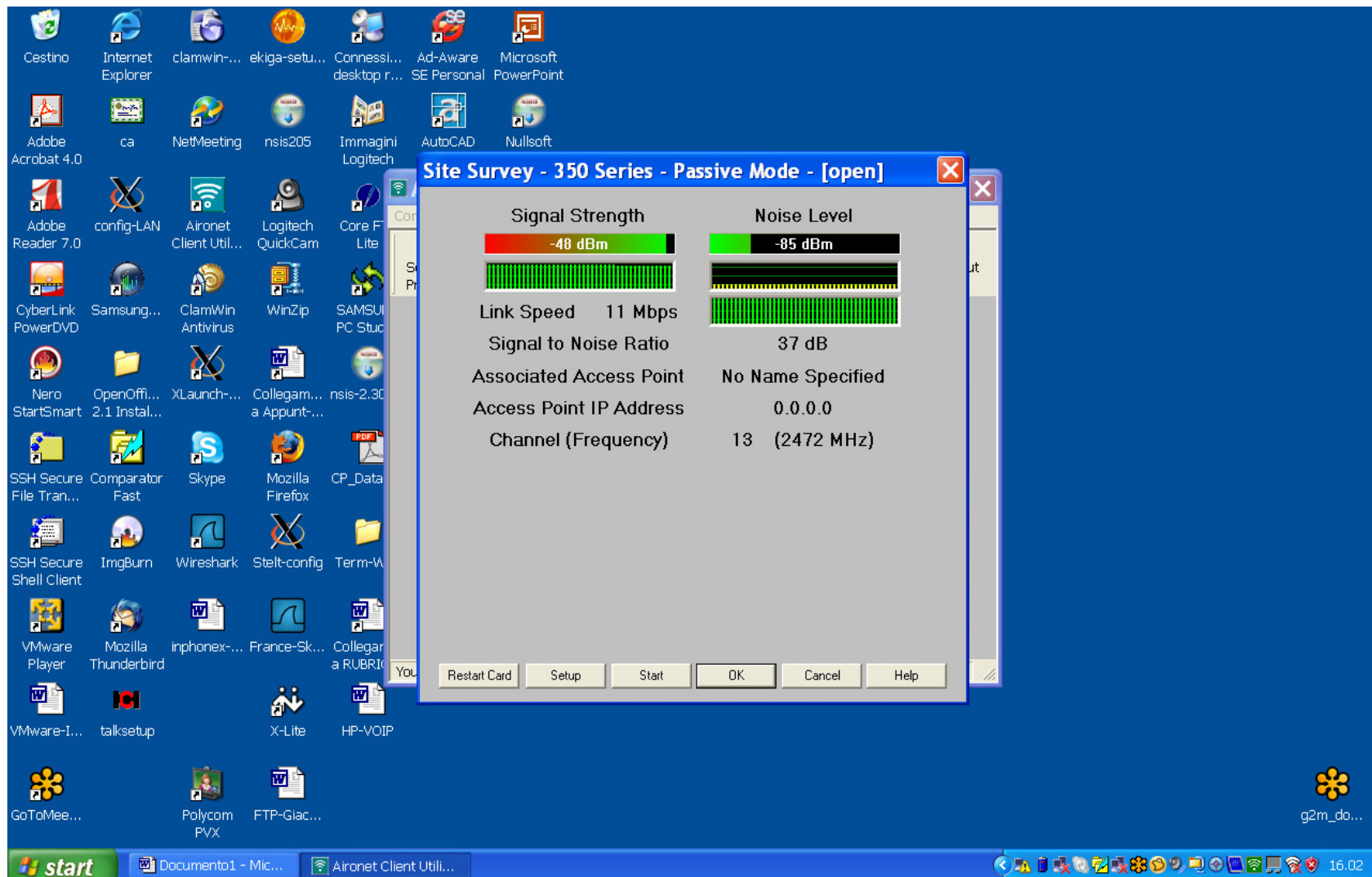



Outdoor area: receiver at 15 mt from AP (-50 dBm)

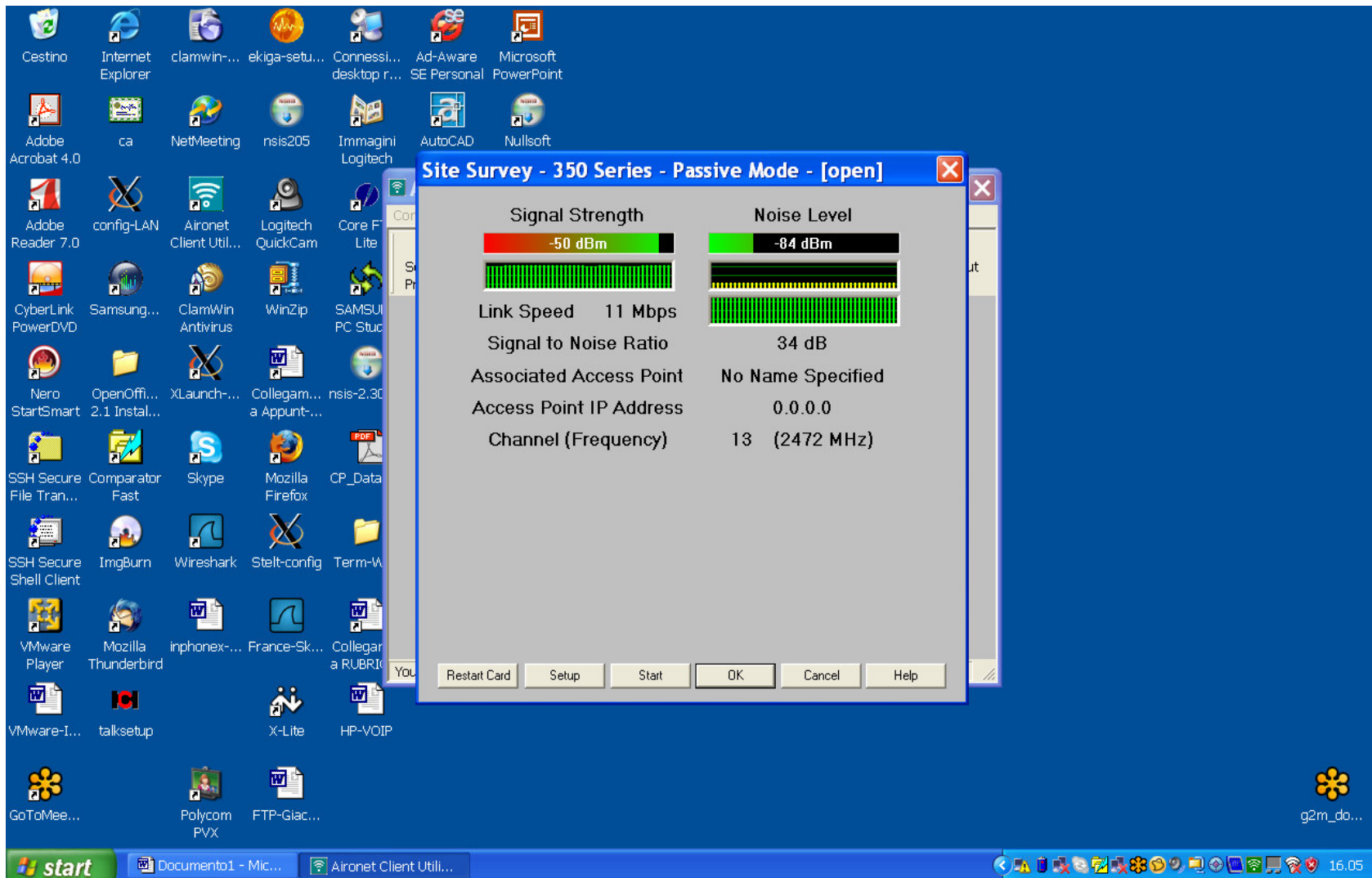



802.11 DSSS: transmitter output theoretical spectrum

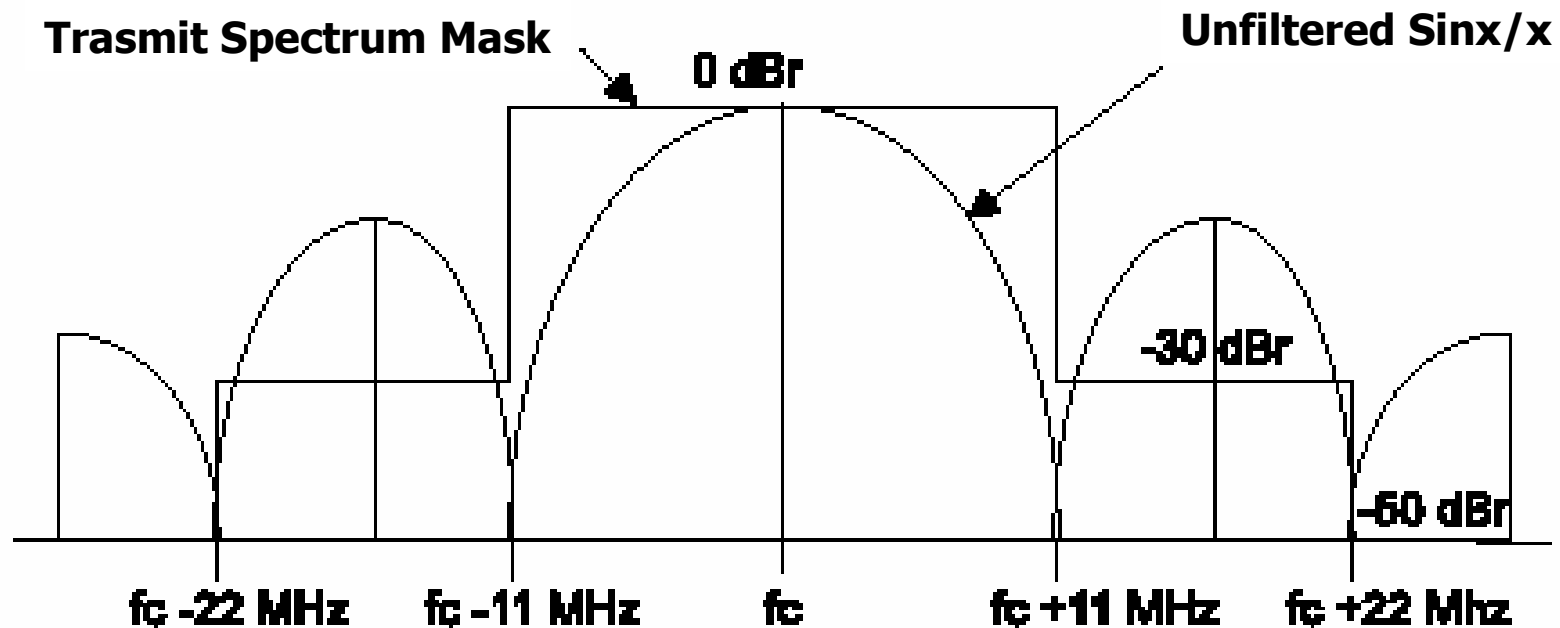



802.11 DSSS: transmitter output real spectrum

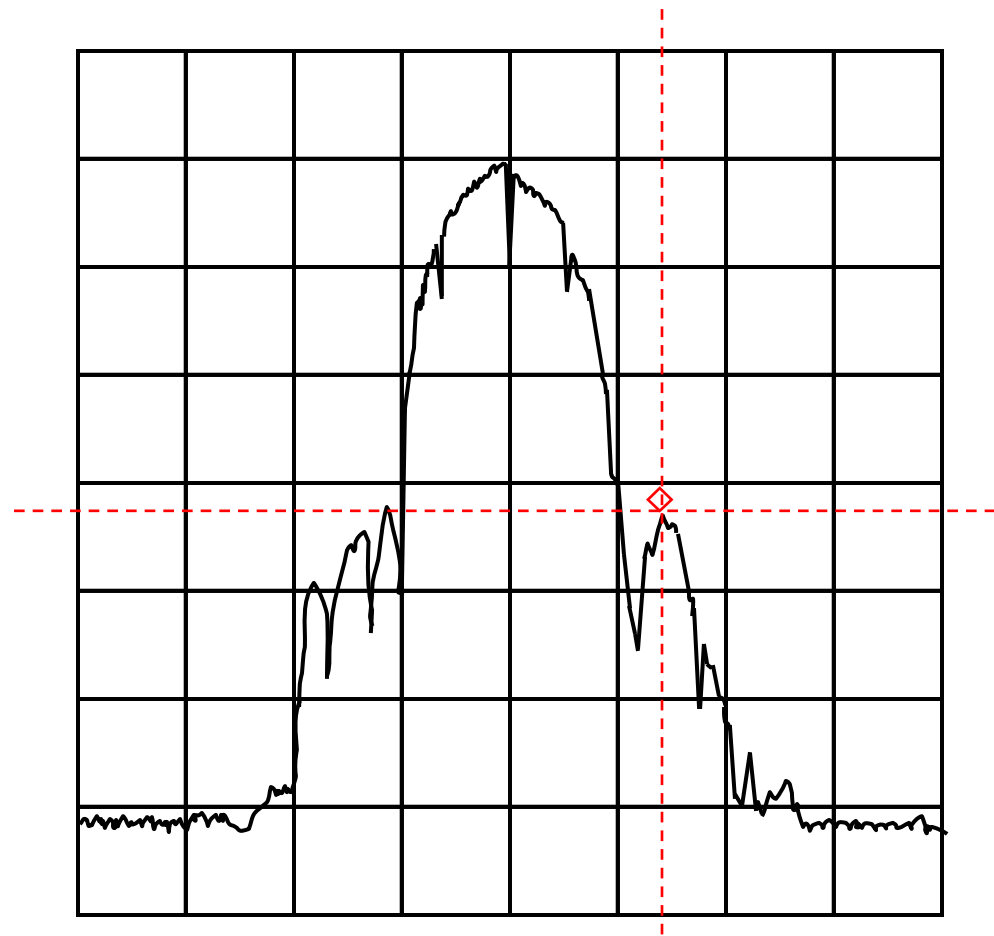

◇ Marker a $\Delta 14,5$ MHz -32,74 dB



Europe: 802.11 slightly overlapping channels

- Cells planning considering 5 channels with 15 MHz spacing

■ 1, 4, 7, 10, 13

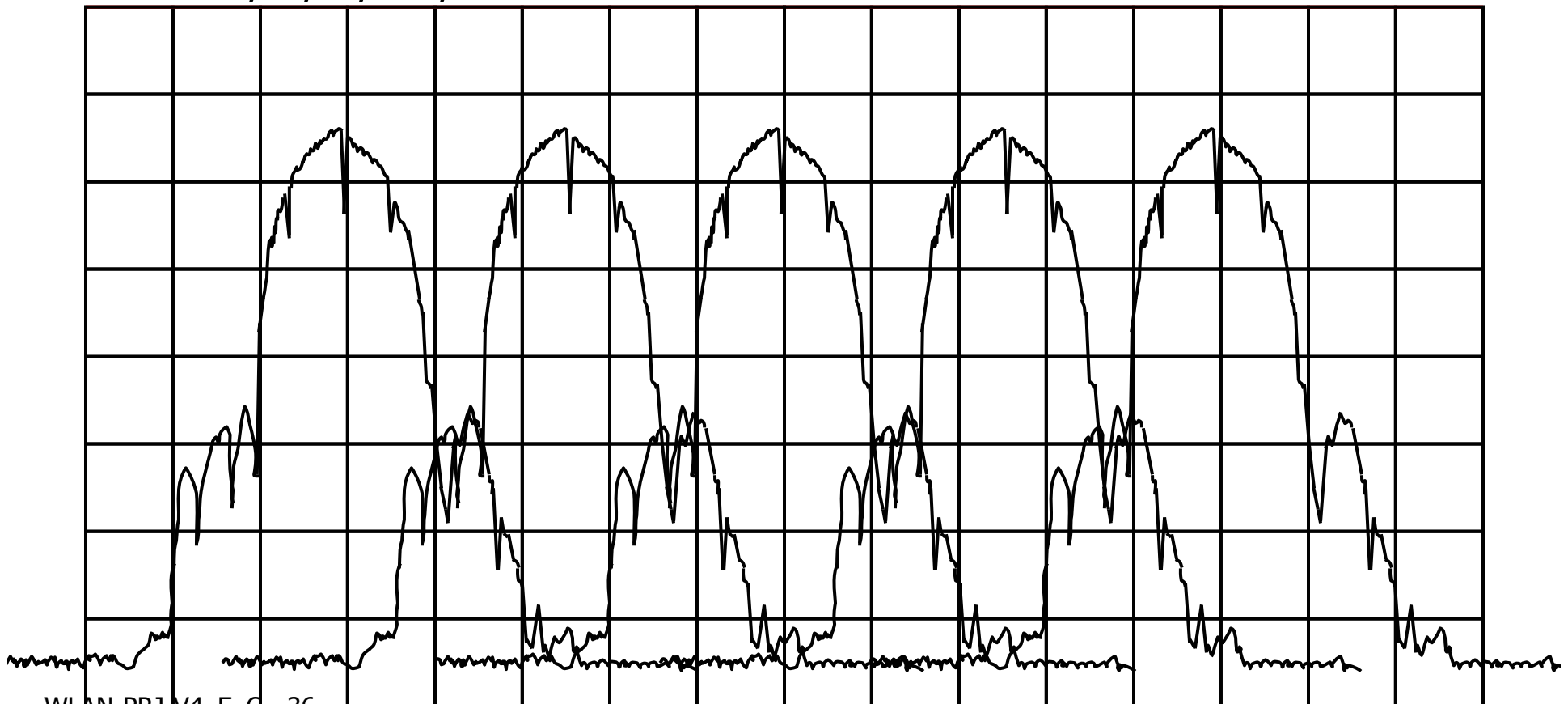



High density area with channel reuse (model 1)

- Critical solution in open plan building
 - Possible interference between AP using the same channel because of low distance and low signal attenuation
 - If STA move away from AP1, the SNR at 9,6 mt implies cell search followed by handover

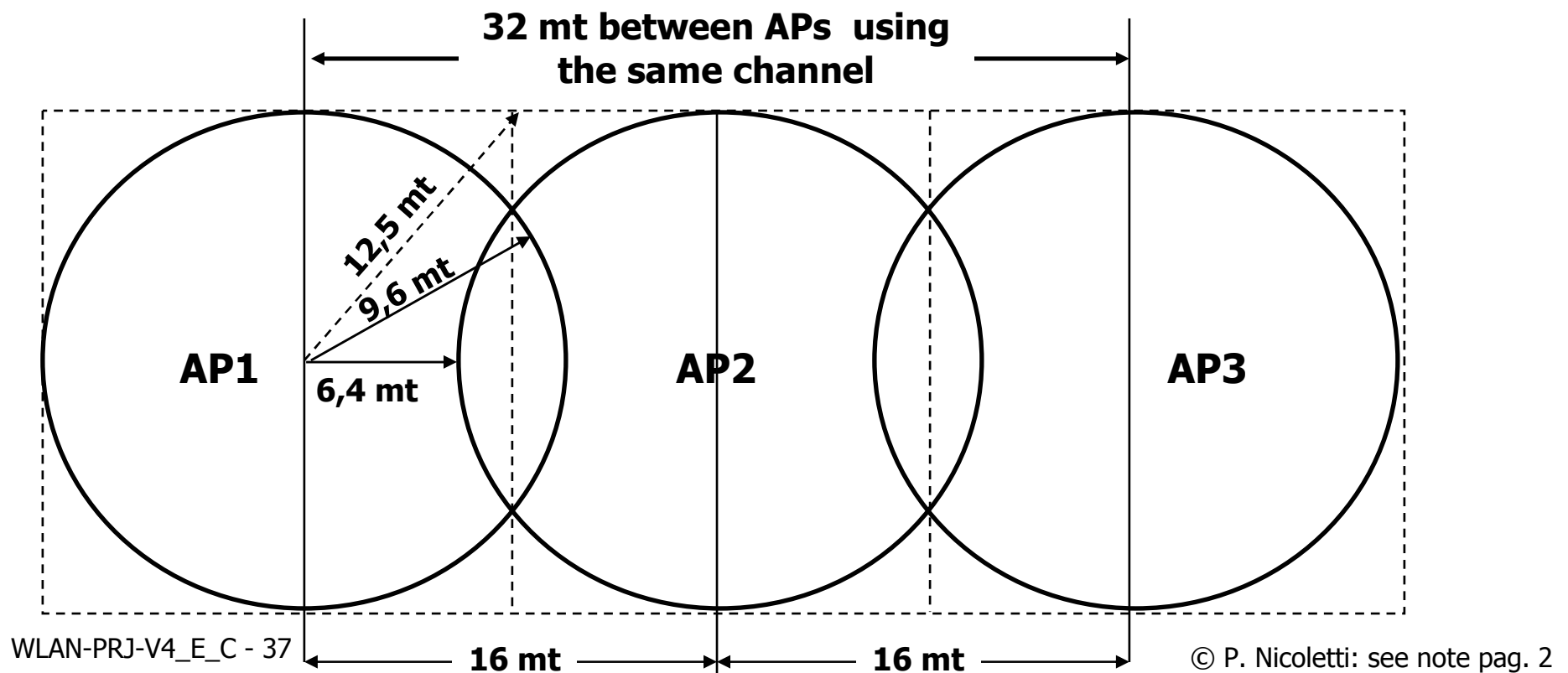



High density area with channel reuse (model 2)

- Critical solution in open plan building
 - Possible interference between AP using the same channel because of low distance and low signal attenuation
 - If STA move away from AP1, the SNR at 12 mt implies cell search followed by handover

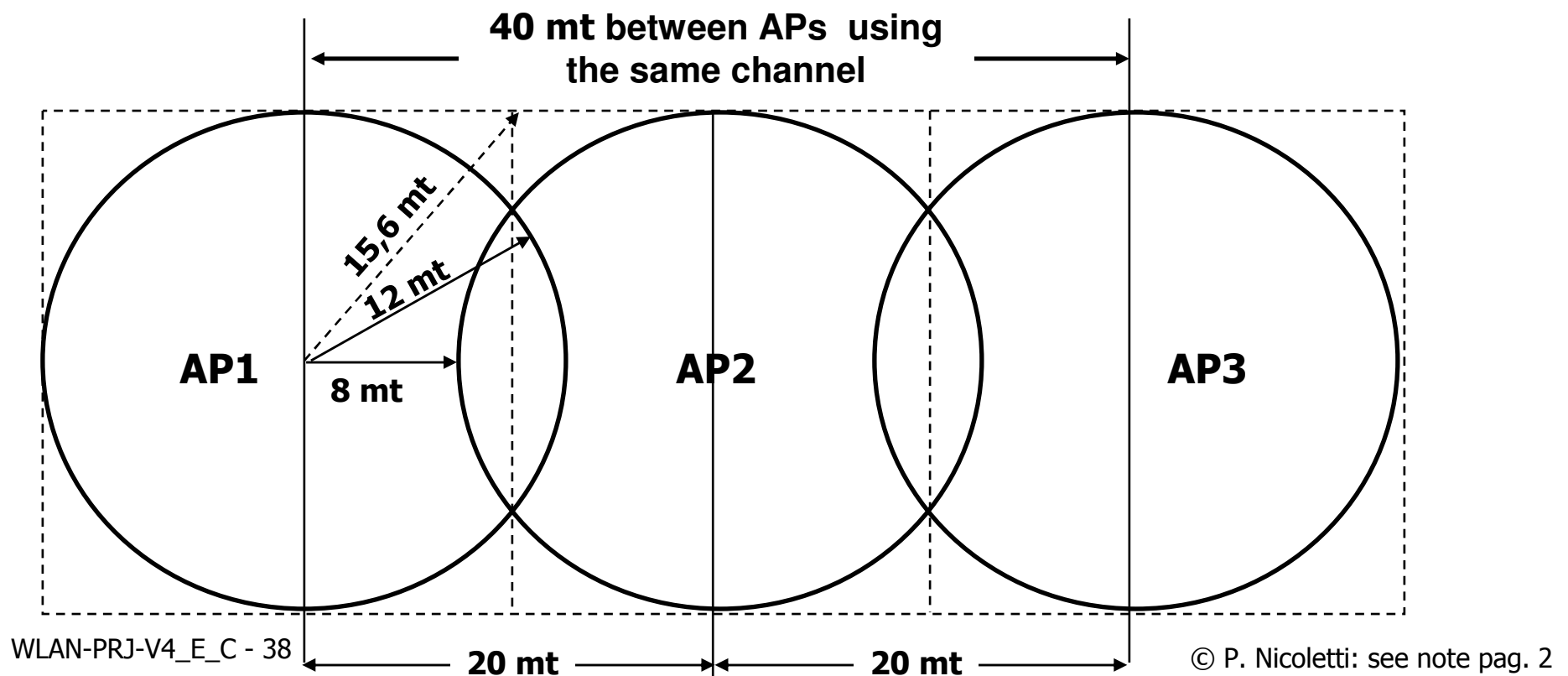



High density area with channel reuse (model 3)

- Acceptable solution in open plan building
 - If STA move away from AP1, the SNR at 18 mt implies cell search followed by handover

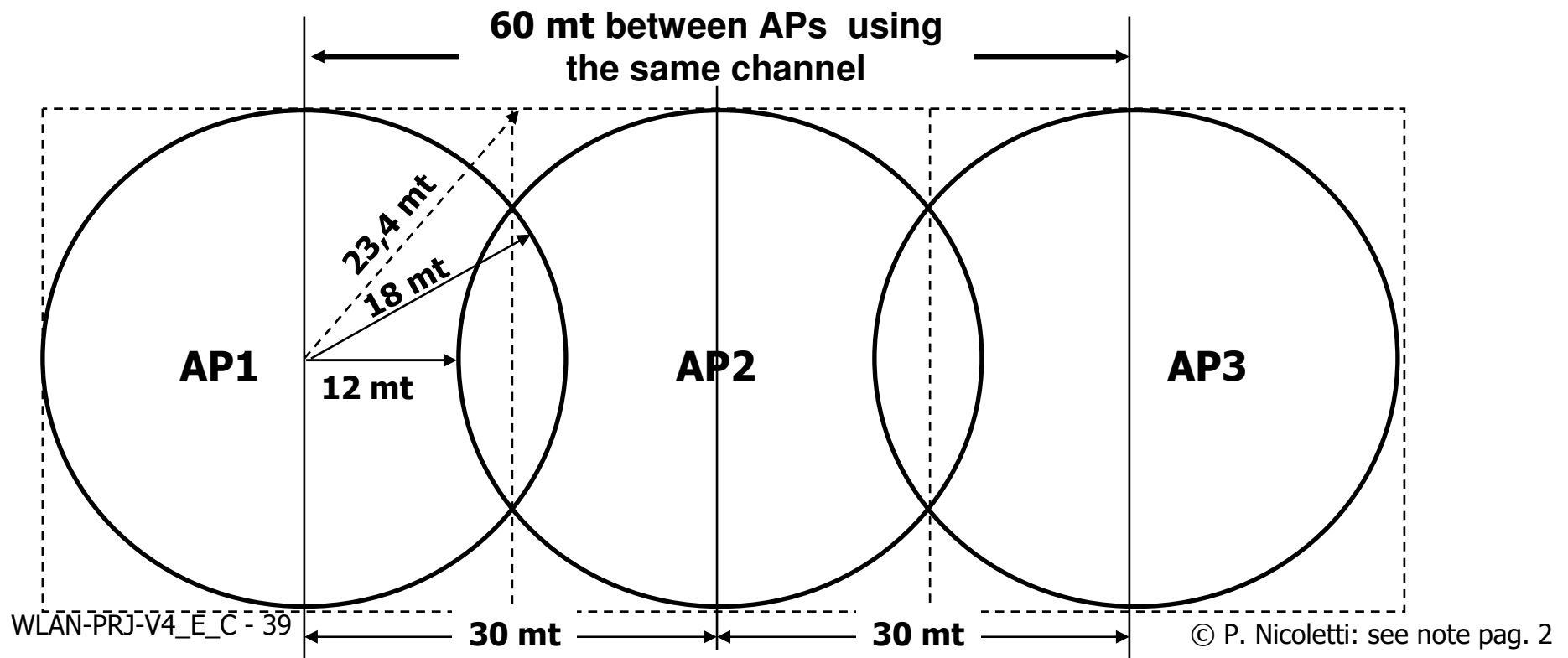



High density area with channel reuse (model 4)

- Good solution in open plan building
 - If STA move away from AP1, the SNR at 24 mt implies cell search followed by handover

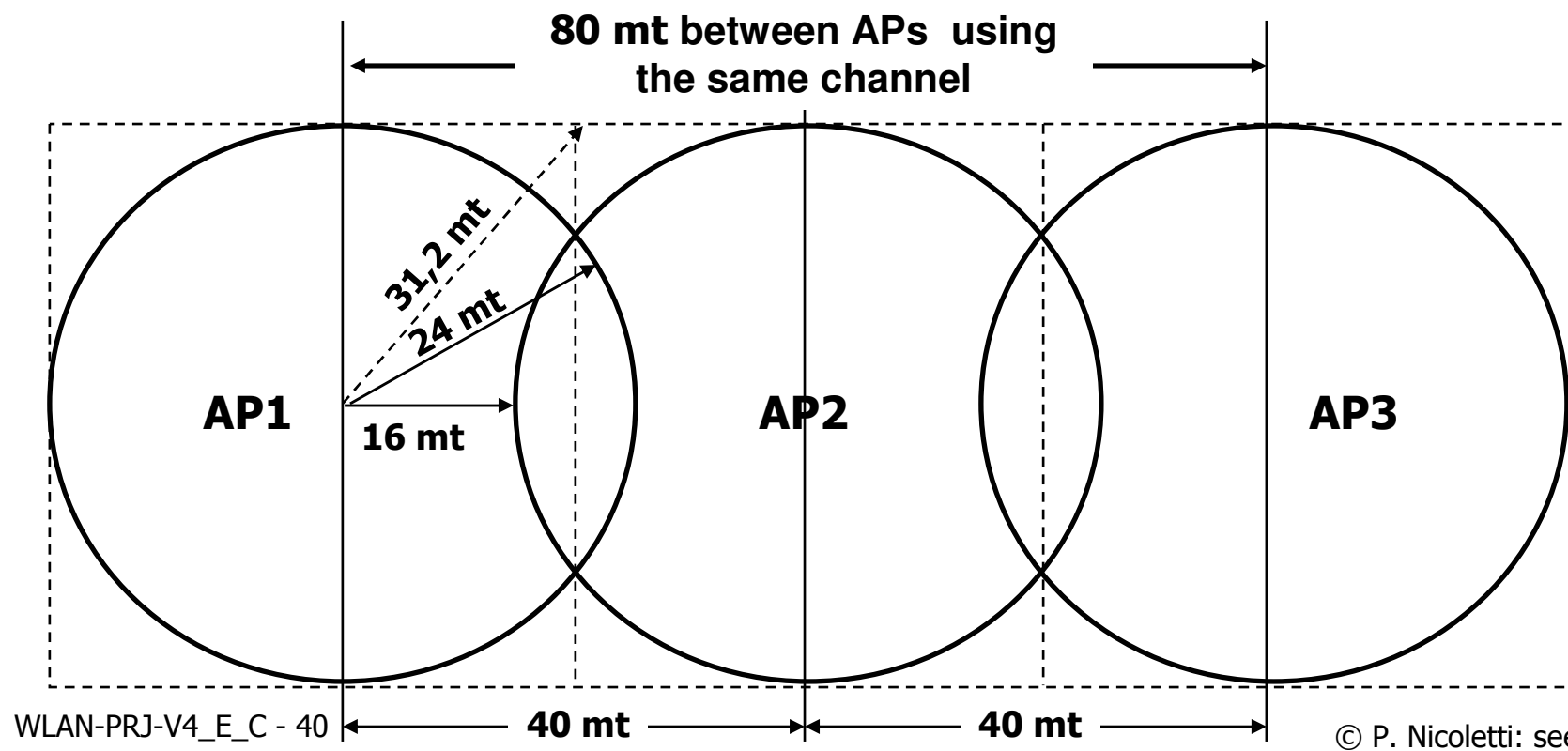



High density area with channel reuse (model 5)

- Good solution for outdoor environments and open plan building
 - If STA move away from AP1, the SNR at 36 mt implies cell search followed by handover

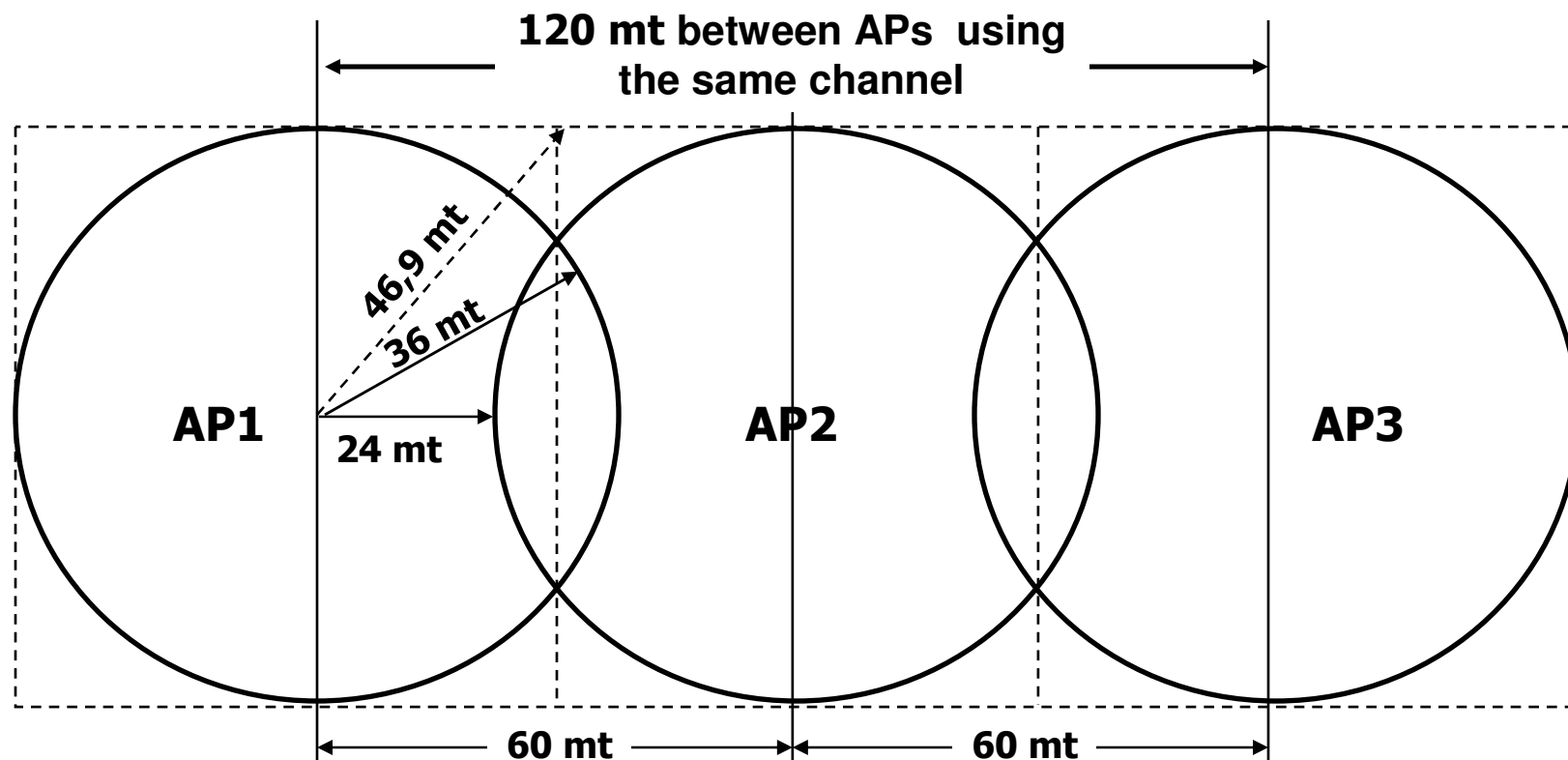



IN-DOOR Wireless-LAN: High density Multi-Cellular infrastructure with Channel Reuse

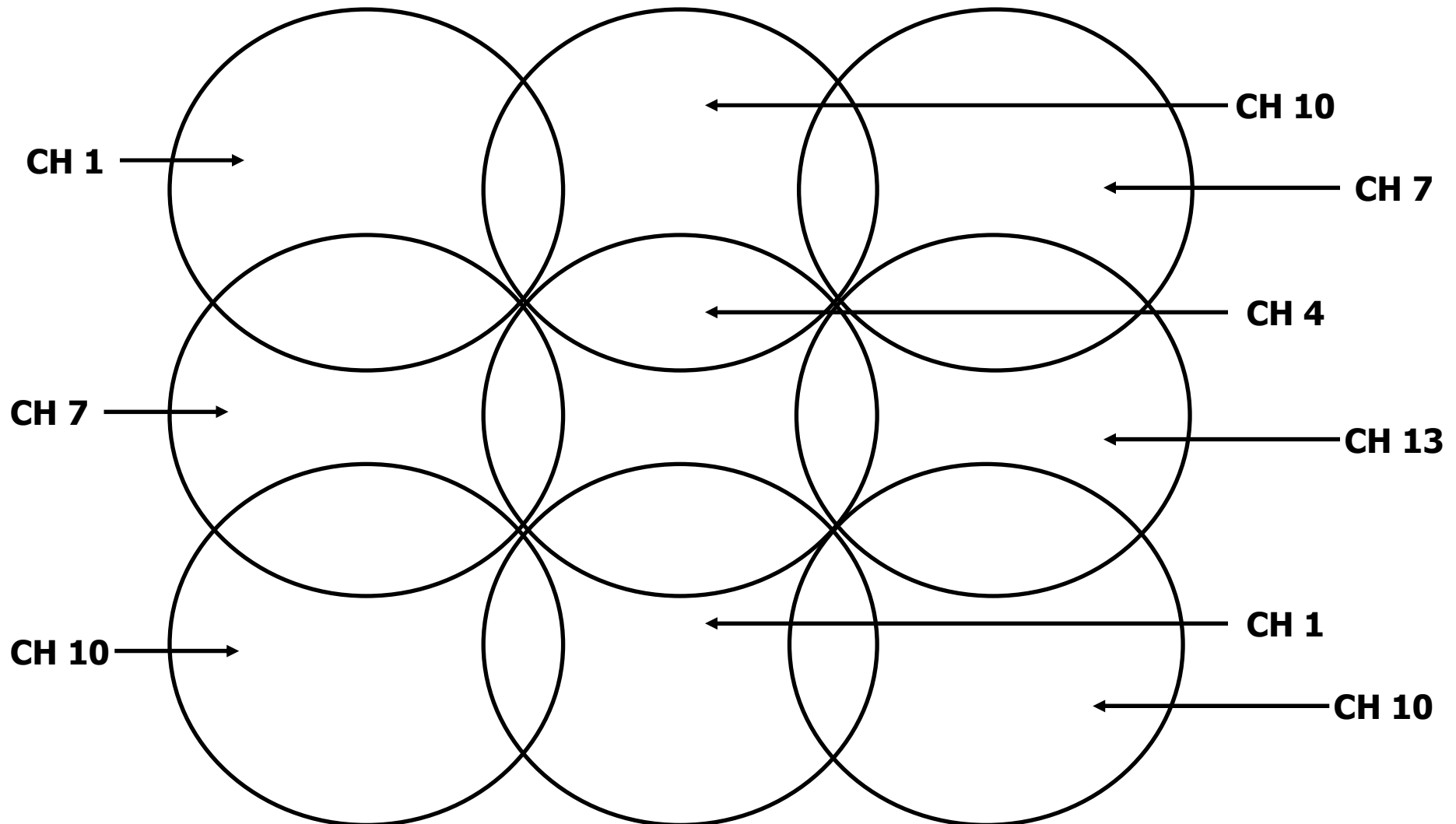



IN-DOOR Wireless-LAN : vertical overlap

- If the floor is small is possible install just 1 AP per floor using non overlapped channel between adjacent floors
- Typical attenuation between floor
 - 22 dB between two adjacent floors
 - 30 dB tra two floor separated by an other floor (example p1 & p3)
 - In this case the attenuation of 30 dB permit to reuse channel



IN-DOOR Wireless-LAN : vertical overlap on small building example

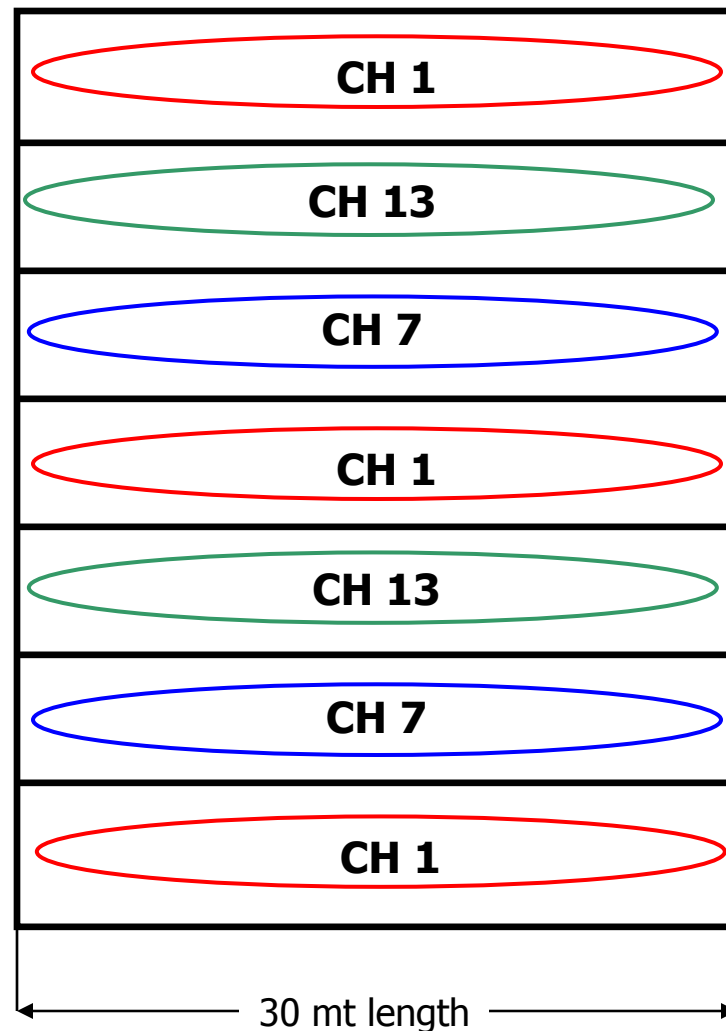



IN-DOOR Wireless-LAN: Idealized coverage model on axis x and y of adjacent floors

- In a building, for effect of the attenuation of about 22 dB between two adjacent floors, the cell coverage is ideally comparable to a series of concentric circular crowns

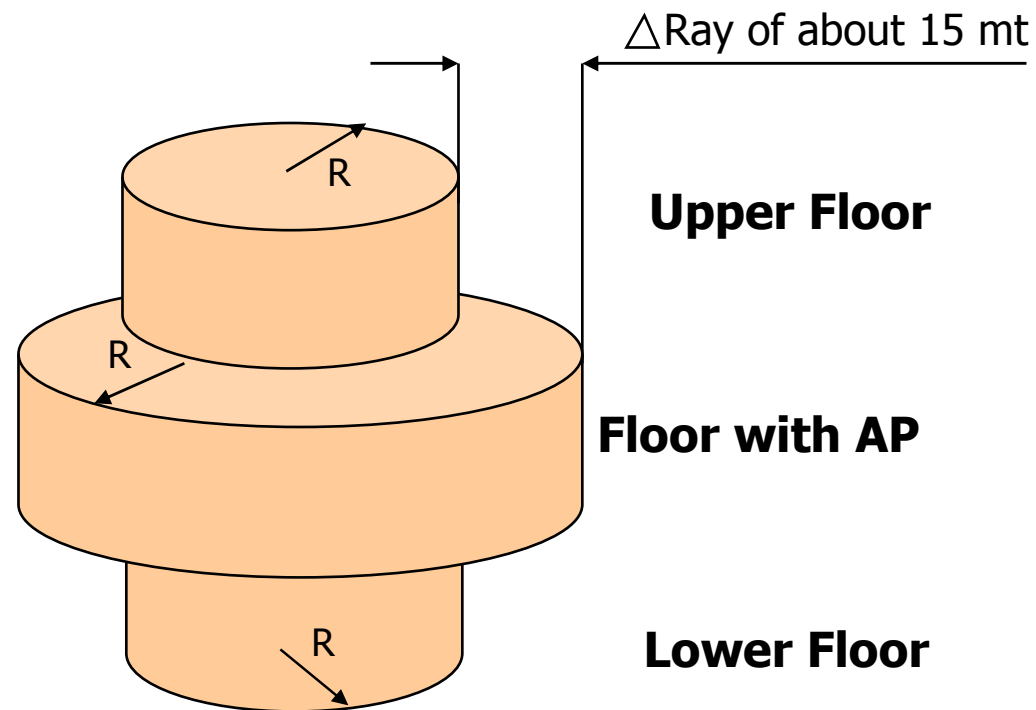

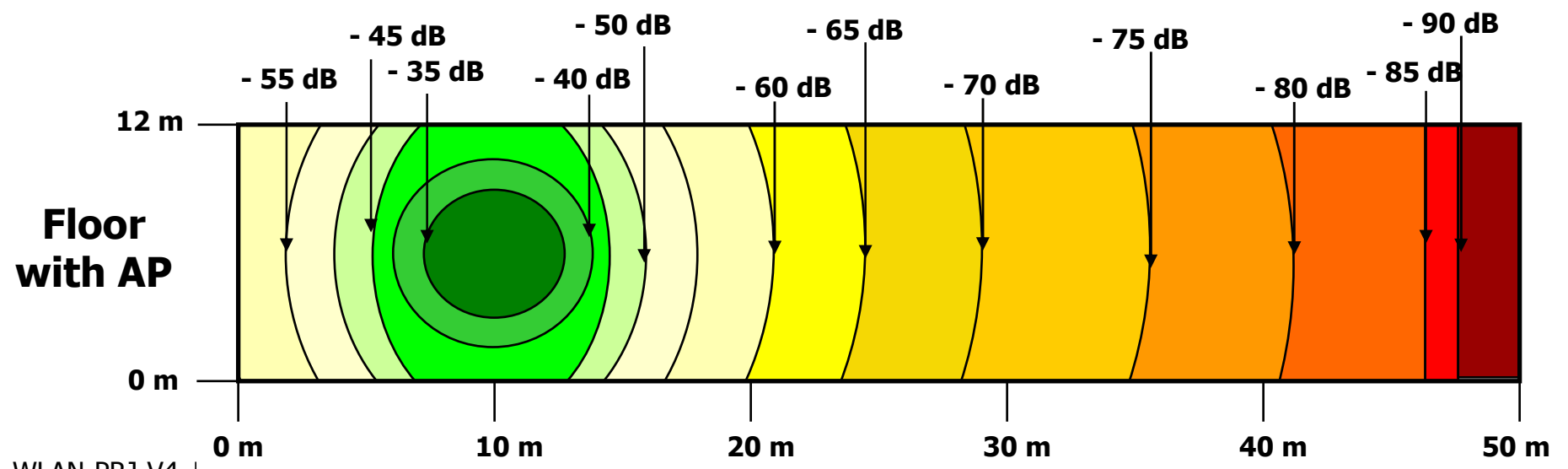
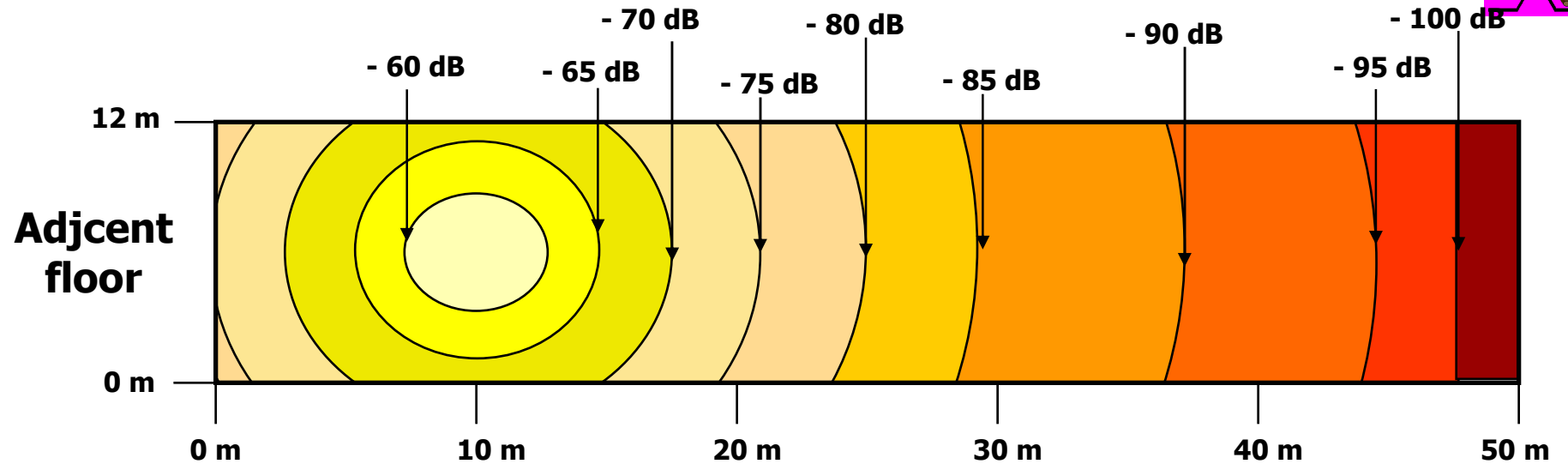



IN-DOOR Wireless-LAN : vertical overlapping cells in a big building

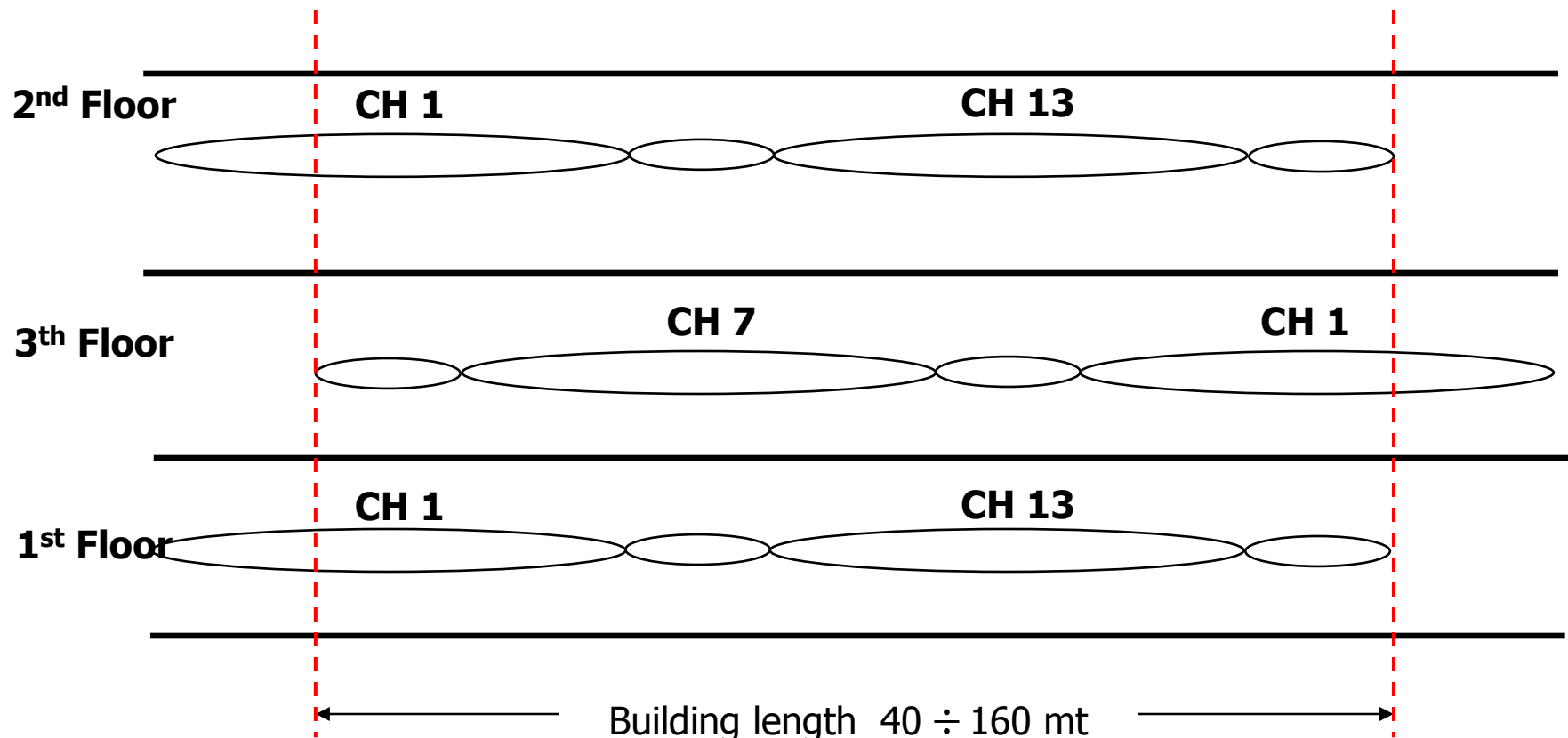



IN-DOOR Wireless-LAN: The choice of antenna type

- Omni Directional antenna
 - low gain, covering at 360 degrees on the horizontal plan and degrees reduced on the vertical plan
 - range gain between 0 and 6 dB
- Patch antenna
 - medium gain, covering angle reduced on the two horizontal and vertical plans



Omni Directional antenna Cisco AIR-ANT1728: ceiling mounting

Dimension and mounting specifications

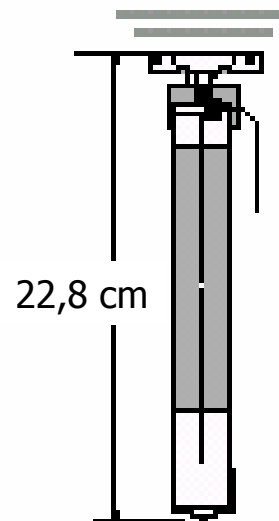

Vertical Radiation Pattern

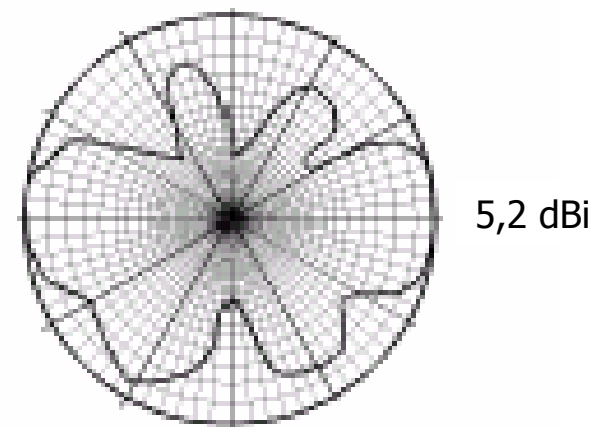



Omni Directional antenna Cisco AIR-ANT1728: Technical Data

Frequency Range	2.4-2.83GHz
VSWR	Less than 2:1, 1.5:1 Nominal
Gain	5.2dBi
Polarization	Vertical
Azimuth 3dB BW	Omni directional 360 degrees
Elevations Plan (3dB BW)	50 degrees
Antenna Connector	RP-TNC
Dimensions (H x W)	9 x 1.25 in.
Mounting	Drop ceiling cross member—indoor only



Omni Directional antenna HUBER+SUNER: ceiling mounting Technical Data

SPA 2400/360/4/20/V

Technical Data

Electrical Properties	
Frequency range	2400 - 2500 MHz
Impedance	50 Ω
VSWR	1.5
Polarization	linear, vertical
Gain	4.0 dBi
3 dB beamwidth horizontal	360°
3 dB beamwidth vertical	25°
Downtilt	20°
Max. power	75 W (CW) at 25°C

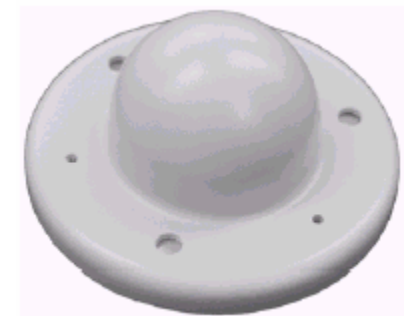



Omni Directional antenna HUBER+SÜNER: ceiling mounting specifications

- Mounting and security instructions
 - dimensions (mm)

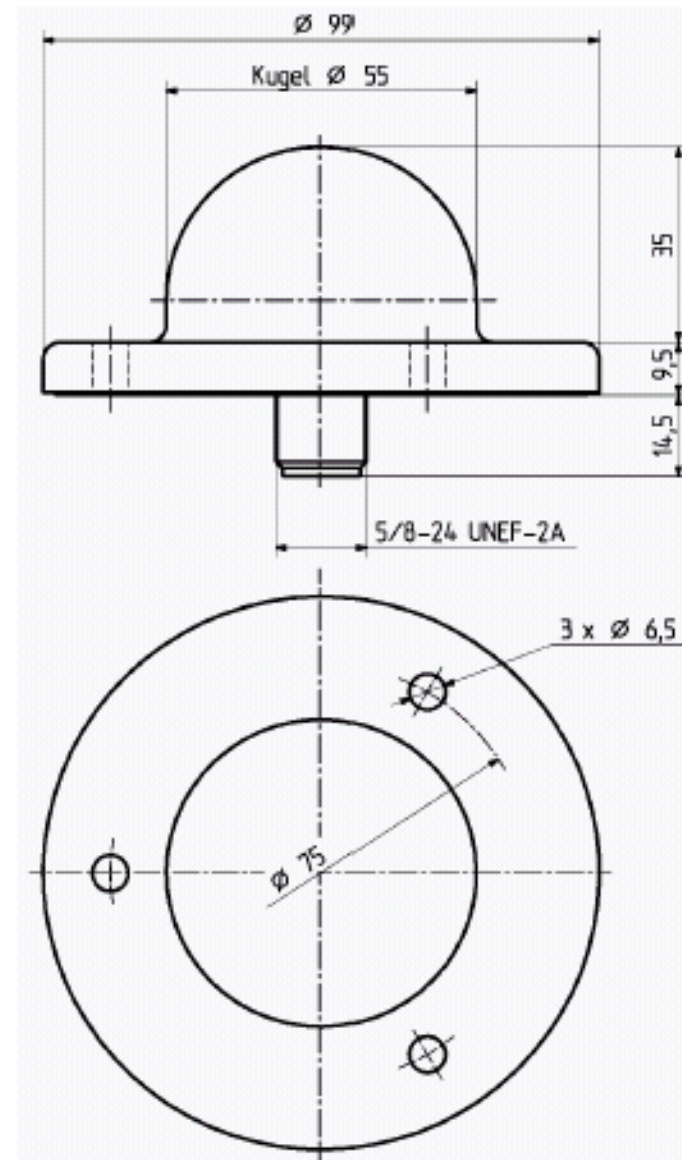



Antenna Omni-direzionale HUBER+SUNER: Radiation Pattern

Radiation Pattern

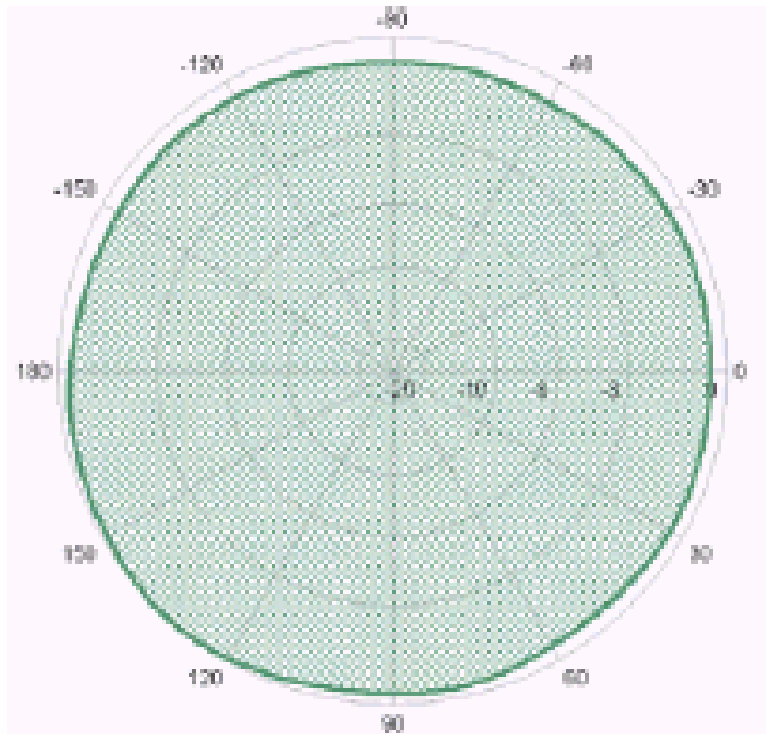

horizontal

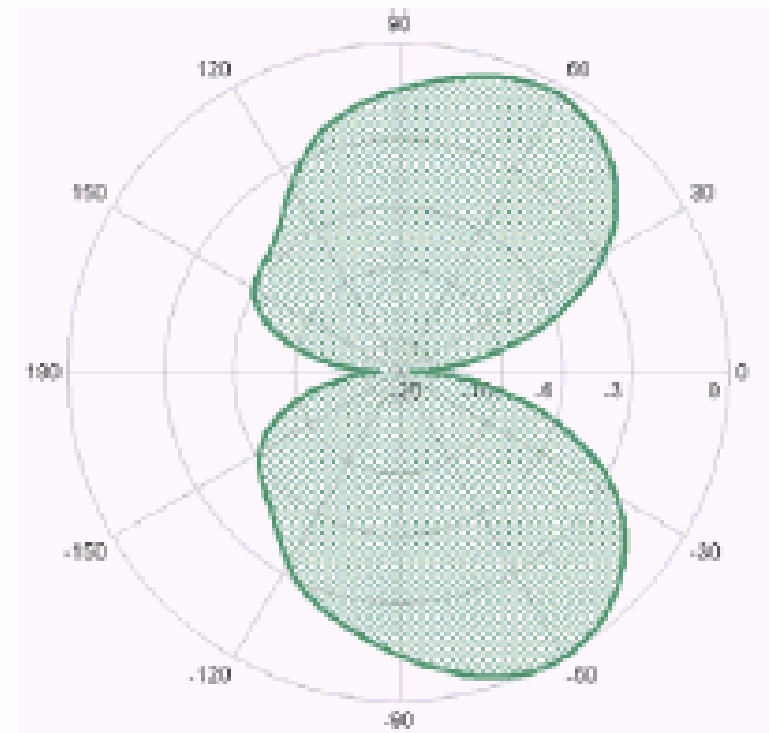

vertical



Dipole Cisco AIR-ANT4941: Technical Data

Dimensions and Mounting Specifications

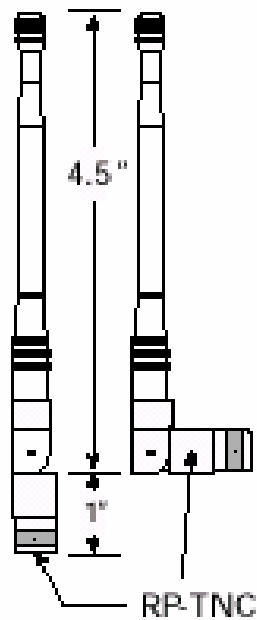

Vertical Radiation

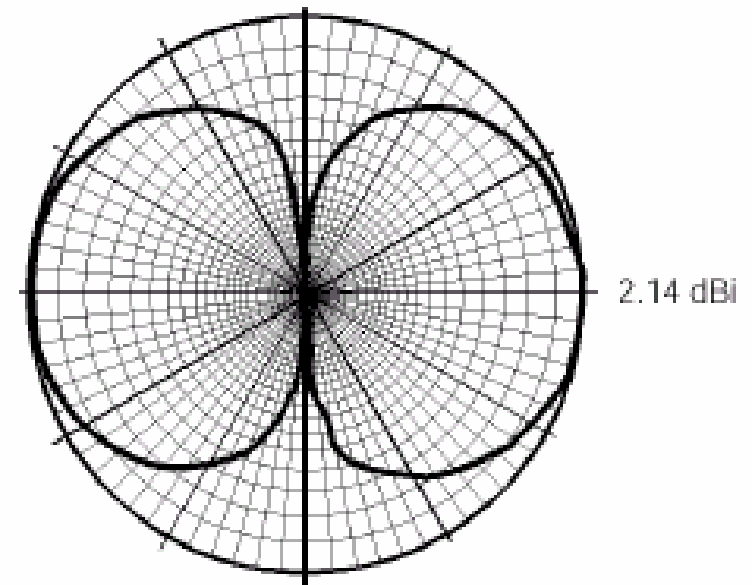



Dipole Cisco AIR-ANT4941: Technical Data

Frequency Range	2.4-2.484GHz
VSWR	Less than 2:1
Power	5 watts
Gain	2 dBi
Polarization	Linear
Azimuth 3dB BW	Omni directional
Elevations 3dB BW	70 degrees
Antenna Connector	RP-TNC
Dimensions (H x W x D)	See Drawing
Mounting	Wall mount



Planar antenna HUBER+SUNER: Dipole Cisco AIR-ANT4941: Technical Data

SPA 2400/75/9/0/V

Technical Data

Electrical Properties

Frequency range	2300 - 2500 MHz
Impedance	50 Ω
VSWR	1.5
Polarization	linear, vertical
Gain	8.5 dBi
3 dB beamwidth horizontal	75°
3 dB beamwidth vertical	60°
Downtilt	0°
Front to back ratio	20 dB
Max. power	75 W (CW) at 25°C





Planar antenna HUBER+SUNER: Radiation Pattern

Radiation Pattern

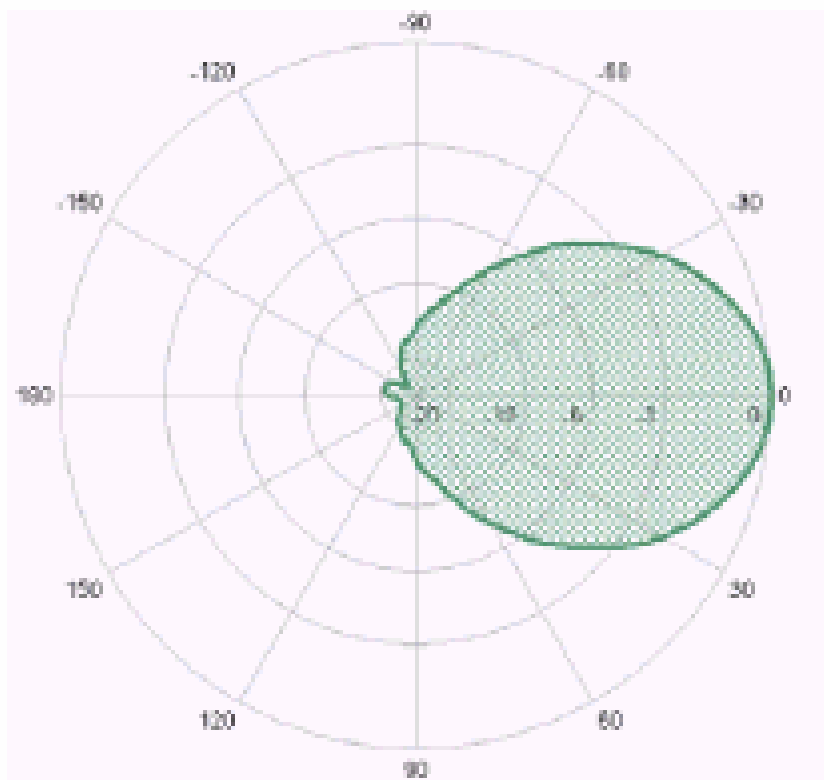

horizontal

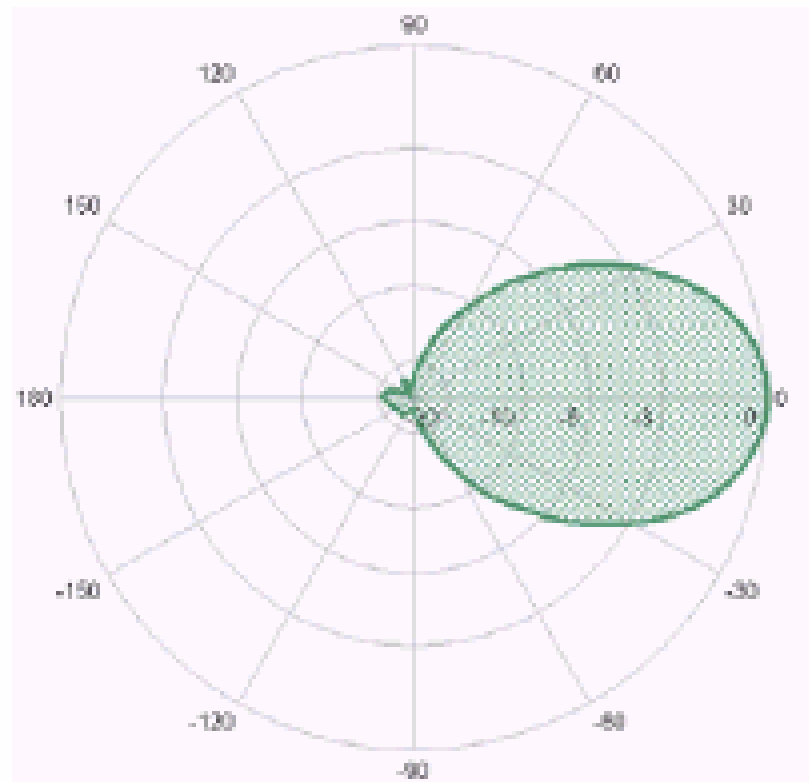

vertical



Planar antenna HUBER+SÜNER: mounting specifications

- Mounting and security instructions
 - dimensions (mm)

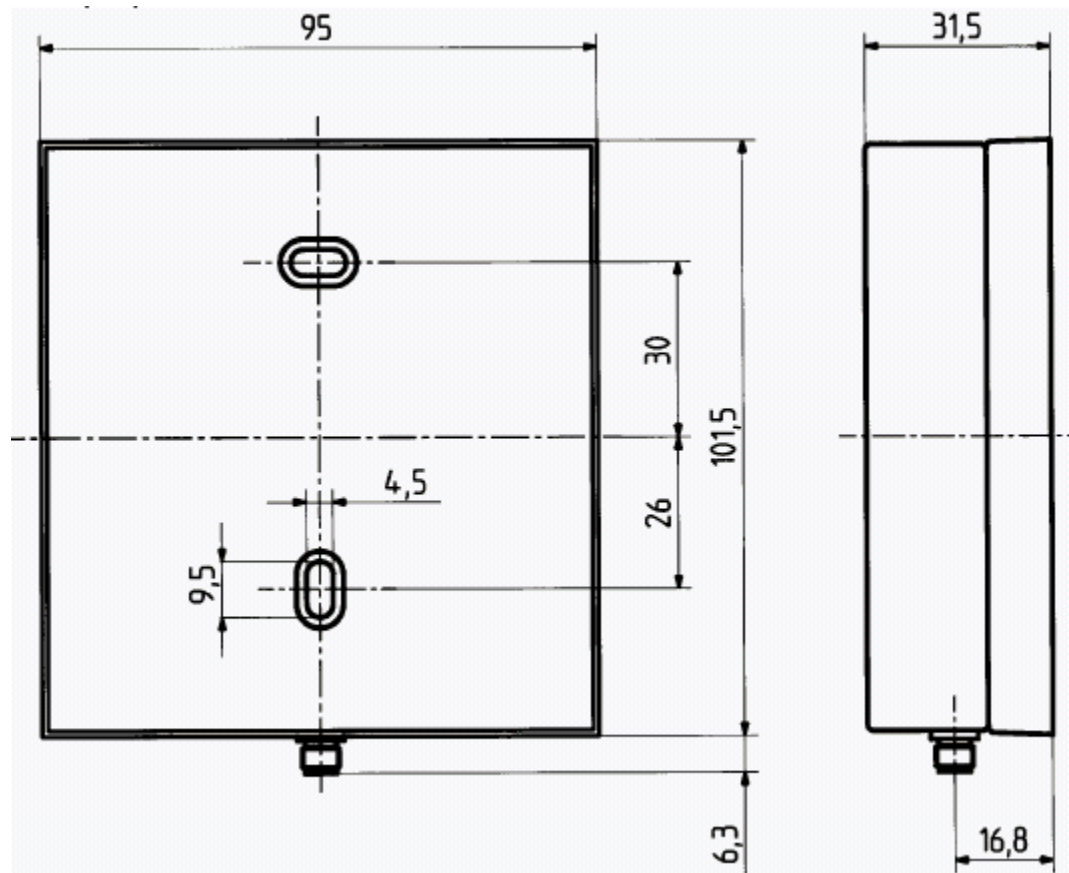



Patch antenna Cisco AIR-ANT1729: Technical Data

Dimensions and Mounting Specifications

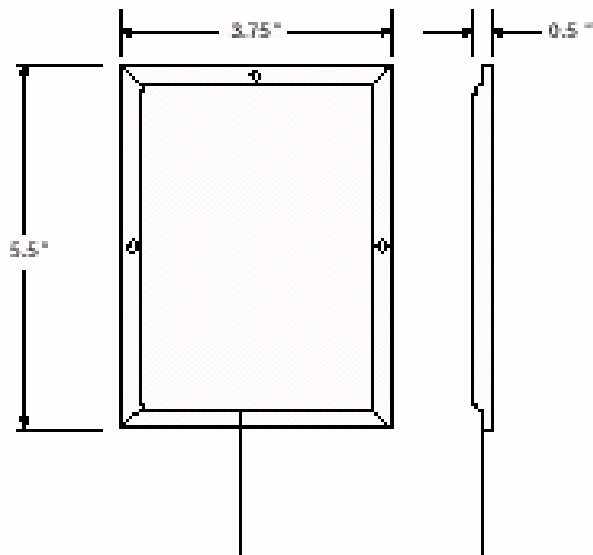

Vertical Radiation

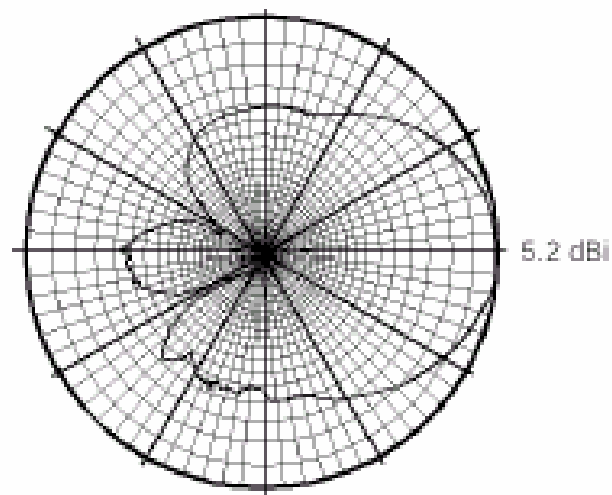

Horizontal Radiation

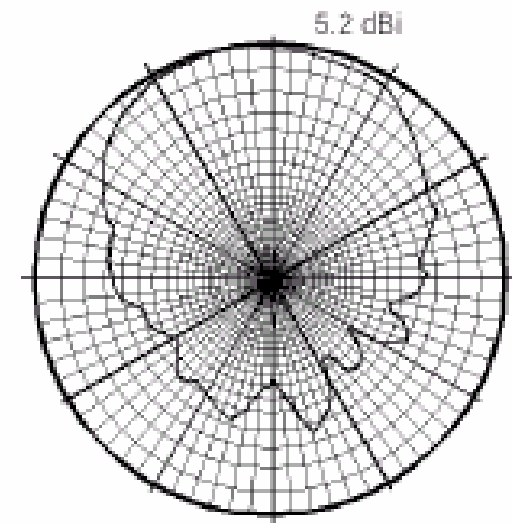



Patch antenna Cisco AIR-ANT1729: Technical Data

Frequency Range	2.4-2.5GHz
VSWR	Less than 2:1
Gain	6dBi
Polarization	Linear
Azimuth 3dB BW	65 degrees
Elevations Plan (3dB BW)	70 degrees
Antenna Connector	RPTNC
Dimensions (H x W x D)	See Drawing
Mounting	Wall mount



Diversity Dipole antenna Cisco AIR-ANT3351

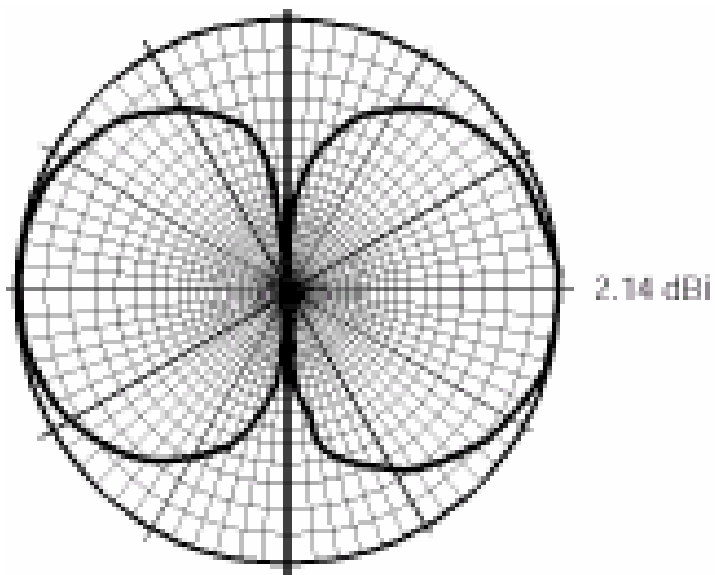

Vertical radiation pattern





Diversity Dipole antenna Cisco AIR-ANT3351: Technical Data

Frequency Range	2.4-2.483GHz
VSWR	Less than 2:1
Gain	2.14 dBi
Polarization	Linear
Azimuth 3dB BW	Omni directional
Elevations 3dB BW	80 degrees
Antenna Connector	MMCX (2)
Dimensions (H x W x D)	6.5 x 7.0 x 2.12 in.



Cable antenna choosing criteria

■ Cable choosing criteria

■ Attenuation

- as higher as much as the distance is high between AP and antenna

■ Diameter and minimum bending ray

- the cable depends on the installation place and on the narrowest passages on which should be installed
- a cable with high minimum bending ray requires several care during installation

■ Costs



IN-DOOR Wireless-LAN: AP physical installation

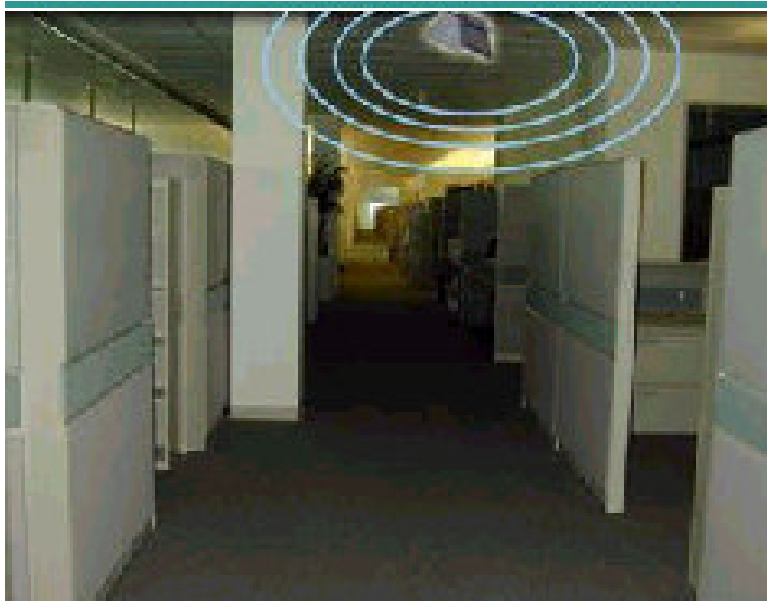

AP Ceiling installation



AP Wall installation



Hot Spot Wireless-LAN

- The cell design, of their installation and channels assignment, follows rules very like those of the Indoor networks
- Access Point allows the access to the wireless network within his covering ray
- The problems of privacy and security:
 - The Hot Spot are typically used to provide the access to Internet
 - Allowing the access to the users qualified through software or appliance which realize functions of Hot Gateway Spot or Captive Portal
 - The user accesses through Web page via HTTPS, is traced and his activity is present in the log file
 - The privacy is not warranted



Hot Spot Gateway

- Hot Spot Gateway (named also Captive Portal):
 - Software or Appliance allows the access to the network through a HTTPS page of presentation which requires Username and password
 - He intercepts the DHCP or ARP requests and sends one splash-page via HTTPS
 - Have at least 2 net interfaces:
 - 2 Ethernet
 - 1 Wireless + 1 Ethernet
 - Has an internal Firewall that by default deny any user access
 - He has control mechanisms to prevent intrusion of not authorized users



Wireless authentication & security: 1

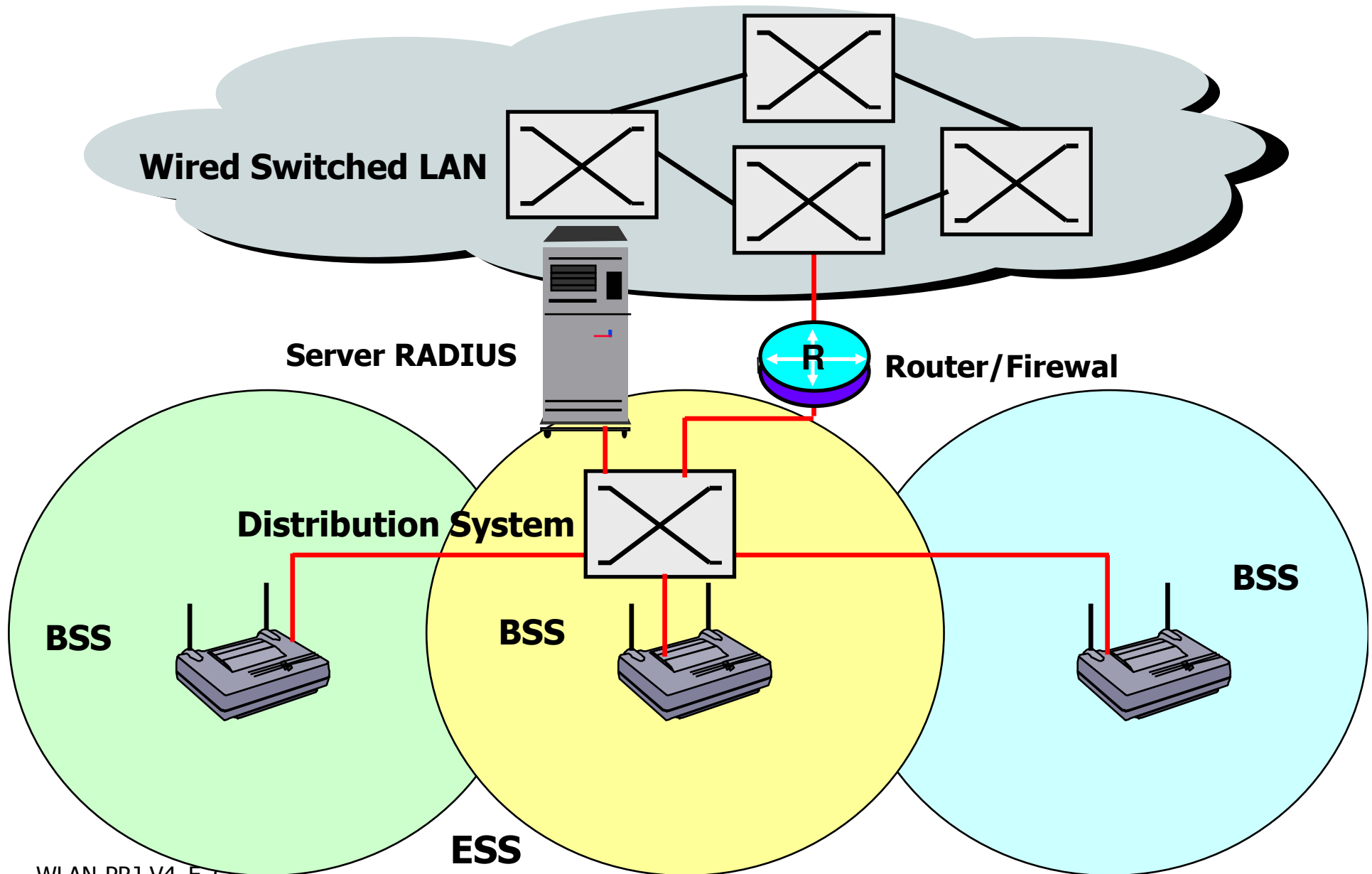



Wireless authentication & security: 2

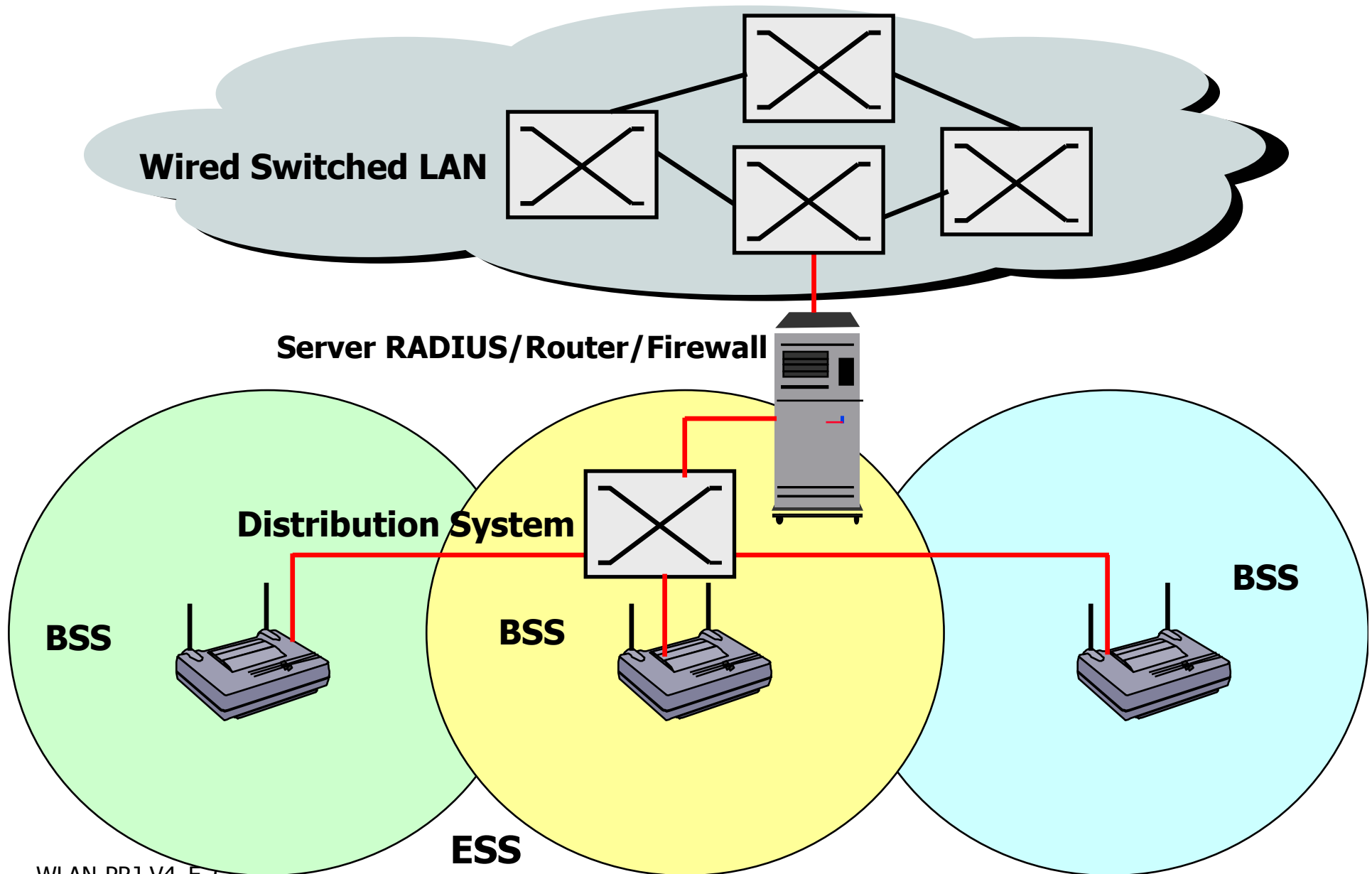



Wireless authentication & security: 3

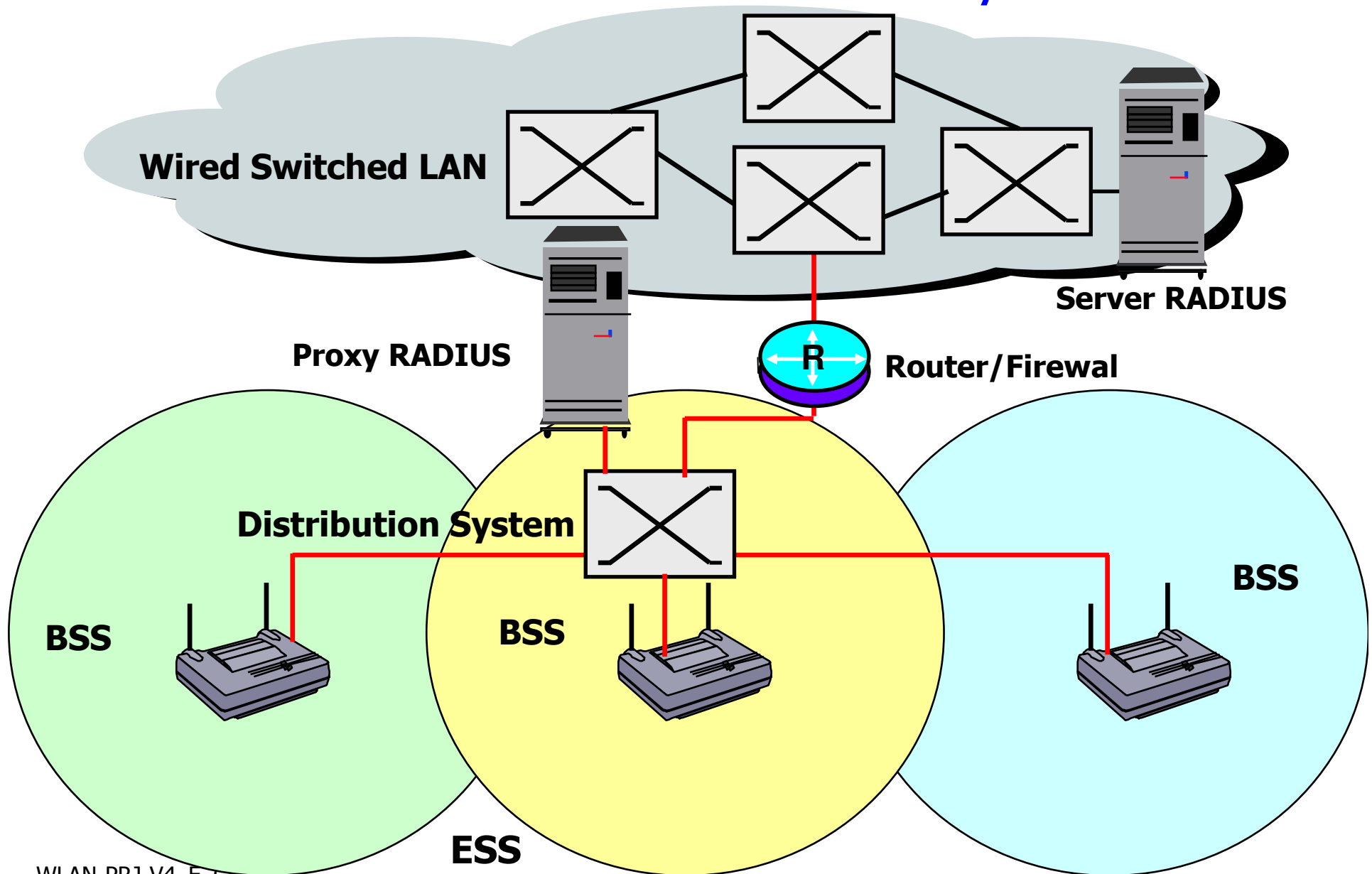



Wireless authentication & security: 4

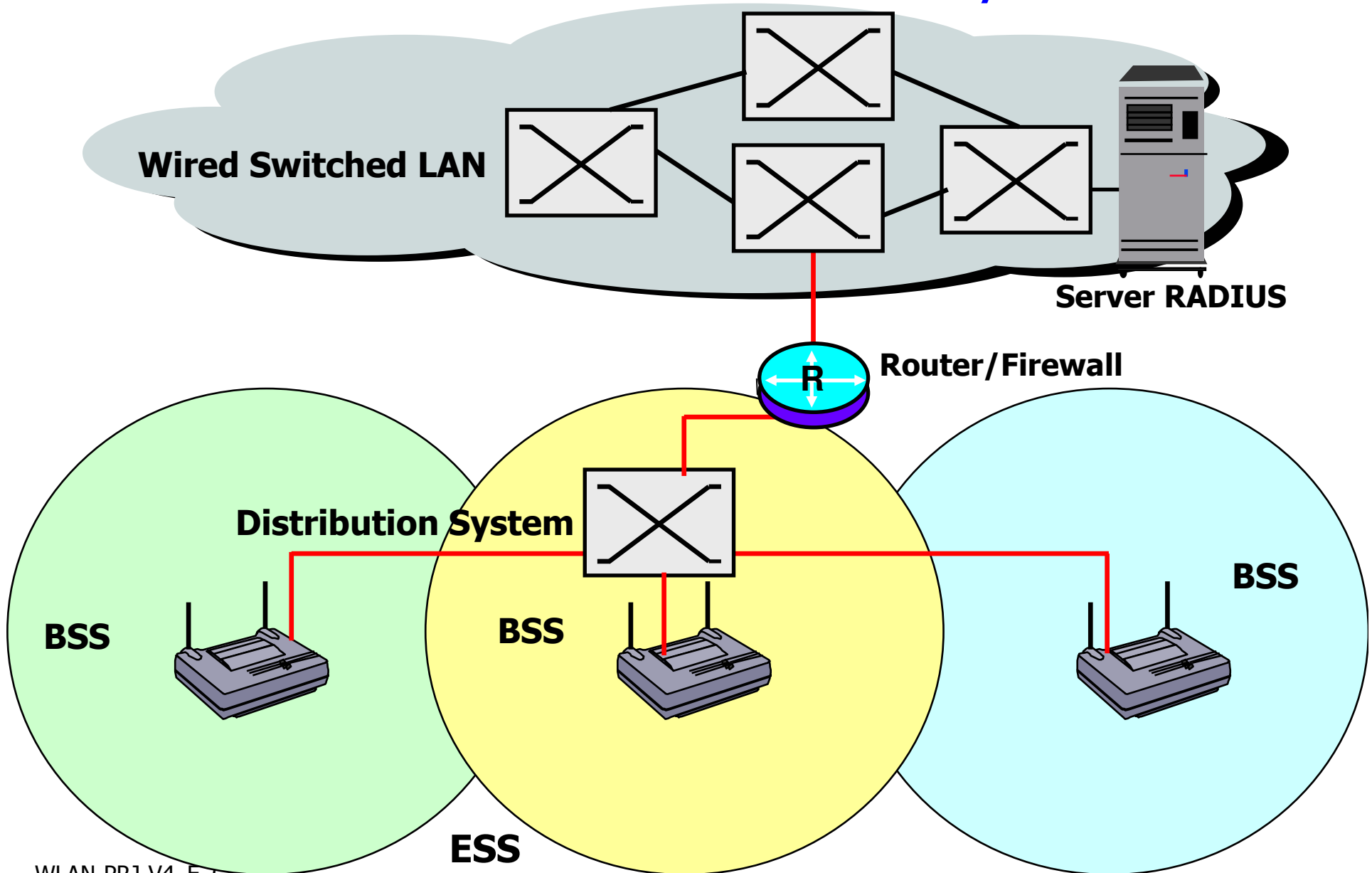



OUT-DOOR Wireless LAN

- Typically use for the connection of buildings which are in Line of Sight (optical visibility)
- Realization of broadband network in rural areas with low investment return
 - costs at least 10 times lower respect the wired networks
- Use of Wireless bridge



Point-to-Point bridge

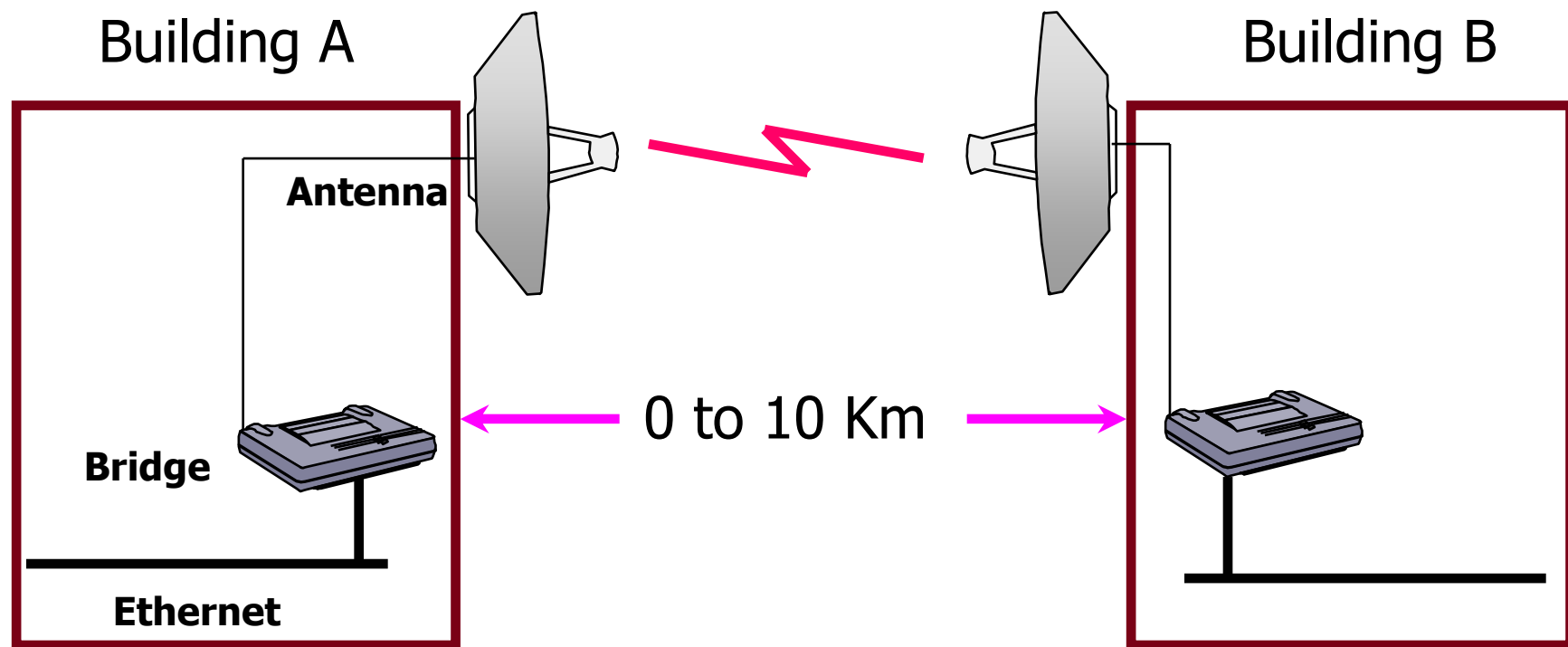



Point-to-Multipoint bridge configuration

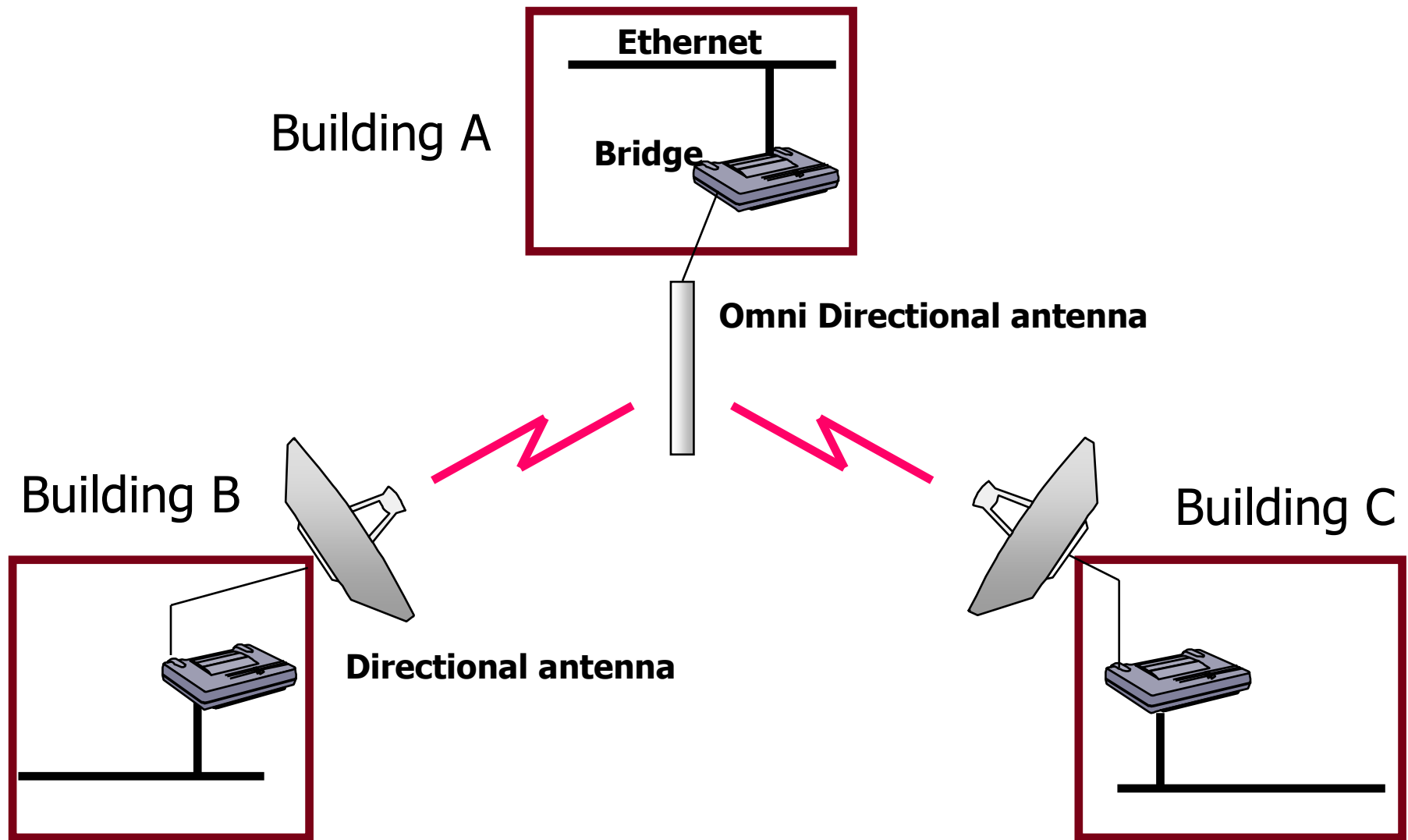



Bridge used AP also as AP

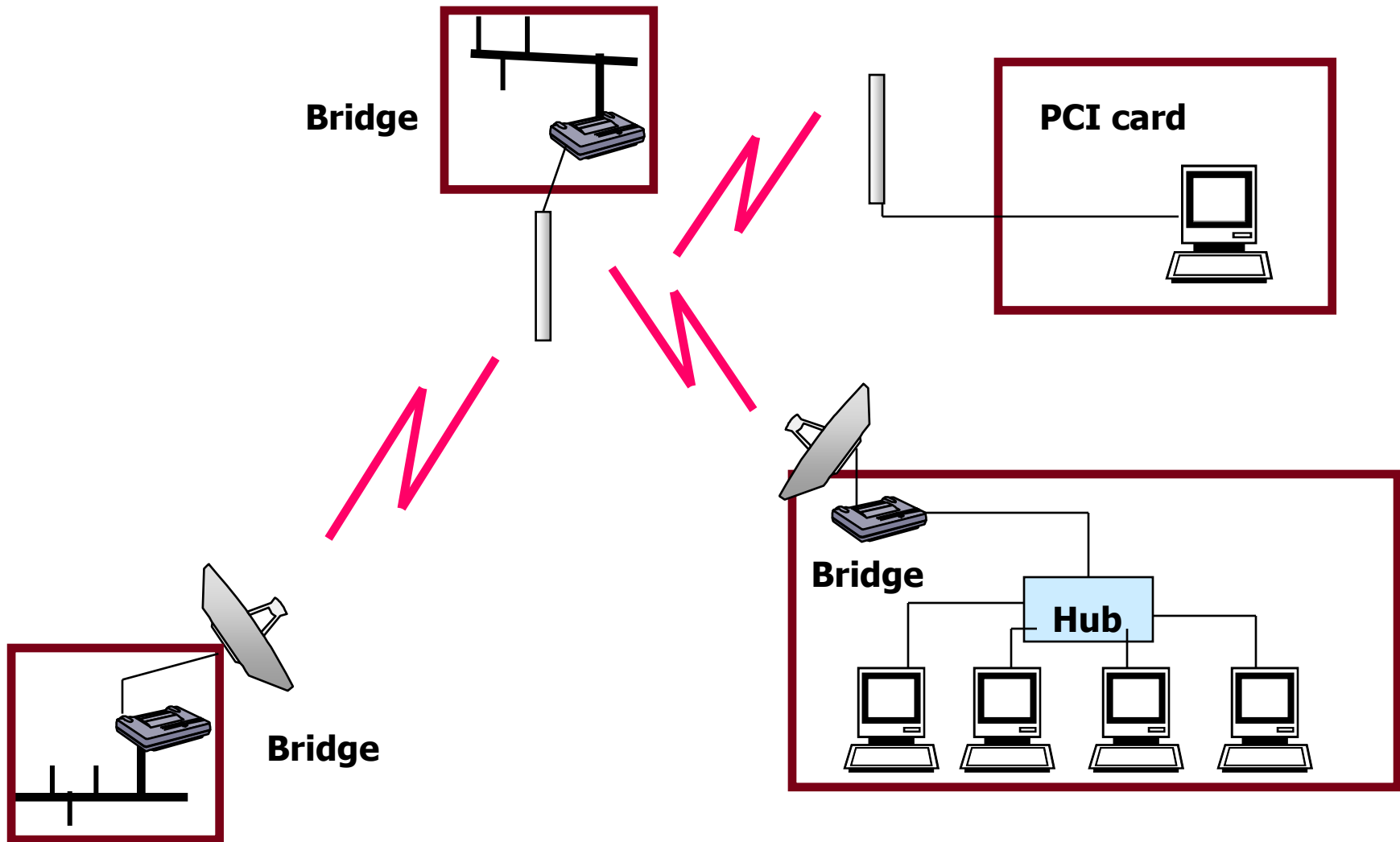



Bridge used as Repeater in the WM

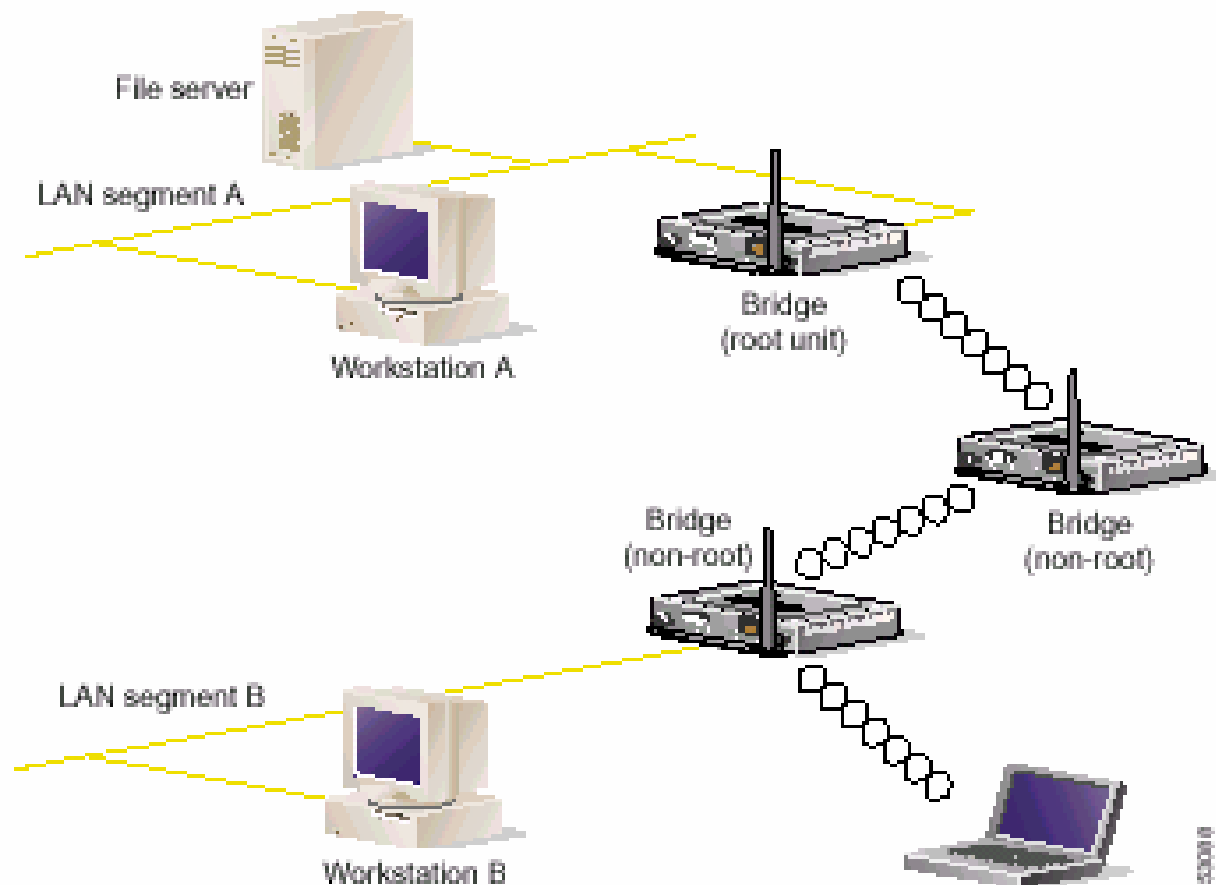



Bridge configuration example with BR350 Cisco

BR350-103 Express Setup

Cisco 350 Series Bridge 11B07.02 BETA

[Home](#) [Map](#) [Help](#)

Uptime: 02:19:59

System Name:	<input type="text" value="BR350-103"/>
MAC Address:	00:40:96:31:63:2a
Configuration Server Protocol:	<input type="text" value="None"/>
Default IP Address:	<input type="text" value="10.0.0.103"/>
Default IP Subnet Mask:	<input type="text" value="255.255.255.0"/>
Default Gateway:	<input type="text" value="10.0.0.1"/>
Radio Service Set ID (SSID):	<input type="text" value="stevierayvaughn"/>
Role in Radio Network:	<input type="text" value="Root Bridge"/>
Optimize Radio Network For:	<input type="text" value="Custom"/>
Ensure Compatibility With:	<input type="text" value="802.11"/>
SNMP Admin. Community:	<input type="text"/>



Use of Wireless Bridge in OUT-DOOR networks

- A bridge must be configured as root or master
 - he assumes also the AP function for the other bridges
- The other bridges must be configured as non-root
 - they do a function such to that of the stations for the association



OUT-DOOR Wireless-LAN: The choice of antenna type

- Omni Directional antenna
 - low gain, covering at 360 degrees on the horizontal plan and 50 degrees in vertical plan
- Yagi and Patch antenna
 - medium gain, covering angle reduced on the two horizontal and vertical plans
- Directional or parabolic antenna
 - high gain, very narrow angle
 - difficult to be aligned
 - it allows to cover very long distances
 - the narrow angle improve interferences immunity



Directional antenna

- Directional antennas come in many different styles and shapes. An antenna does not offer any added power to the signal, and instead simply redirects the energy it received from the transmitter.
 - By redirecting this energy, it has the effect of providing more energy in one direction, and less energy in all other directions.
 - As the gain of a directional antenna increases, the angle of radiation usually decreases, providing a greater coverage distance, but with a reduced coverage angle.

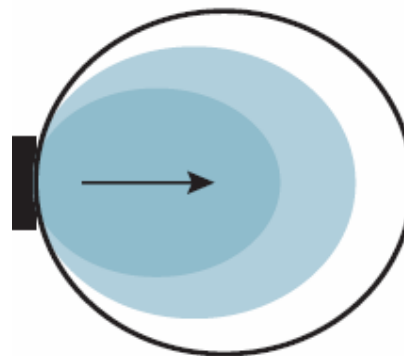



Antenna polarization

■ Horizontal

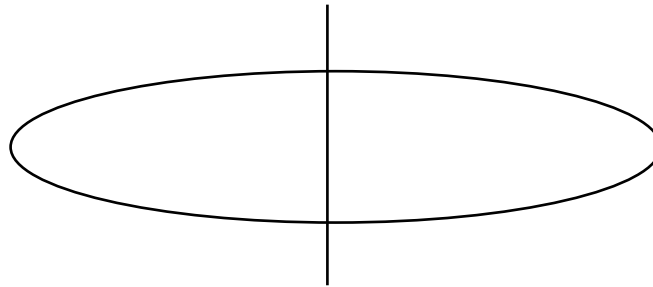

■ Vertical

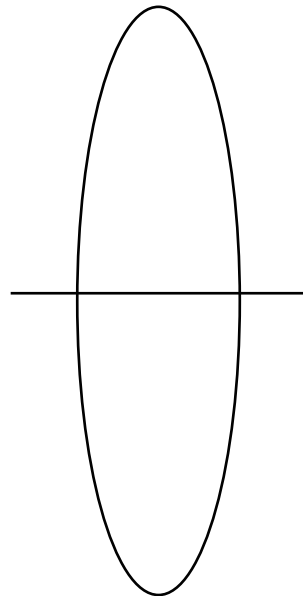



Cisco Omni Directional Antenna

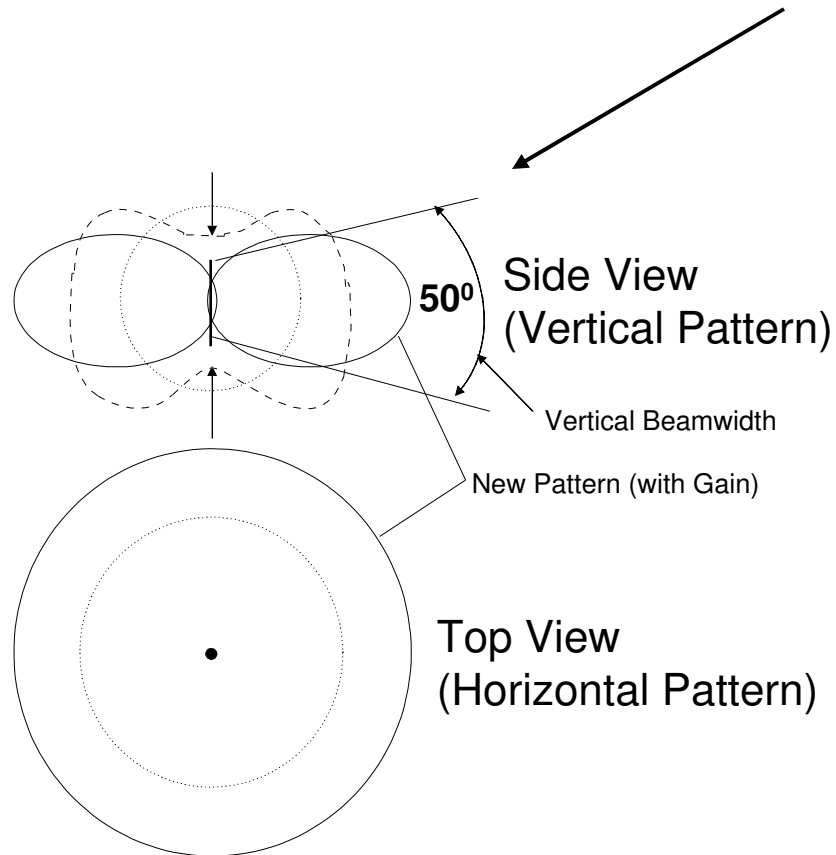



Antenna Sector Omnia Alvarion

- Group of 3 antennas with wide angle (120°) has a combined effect which reproduces omni directionality





Antenna Sector Omnia Alvarion: Technical Data

Specifications	
Purpose	For use with 3 - BreezeACCESS II AU (Access Units)
Frequency Range	2.4 – 2.5 GHz
VSWR	1.5:1
Gain	14 dBi per sector
Power	50 Watts
H-Plane Beamwidth	3 – 120° sectors (360°)
E-Plane Beamwidth	16°
Input Impedance	50 ohms
Nominal Isolation	-68 dB
Single Sector Front to Back	-50 dB
Polarization	Vertical
Lightning protection	DC grounded
Termination	18 in. LMR-195 N-type male connector
Mechanical	
Dimensions	19.75" x 4.7" x 3"
Radome	ASA-ABS, UV resistant
Maximum Wind Speed	125 MPH
Wind Load	Lateral Trust: 138 lbs @125 MPH
Weight	9 lbs
Mounting	Pipe Mount 1.25" to 3.125" OD Center Pipe Mount (1.25" OD Pipe Included)
Mechanical Tilt	-5° UP to +10° down per sector



Antenna Sector Omnia Alvarion: Technical Data

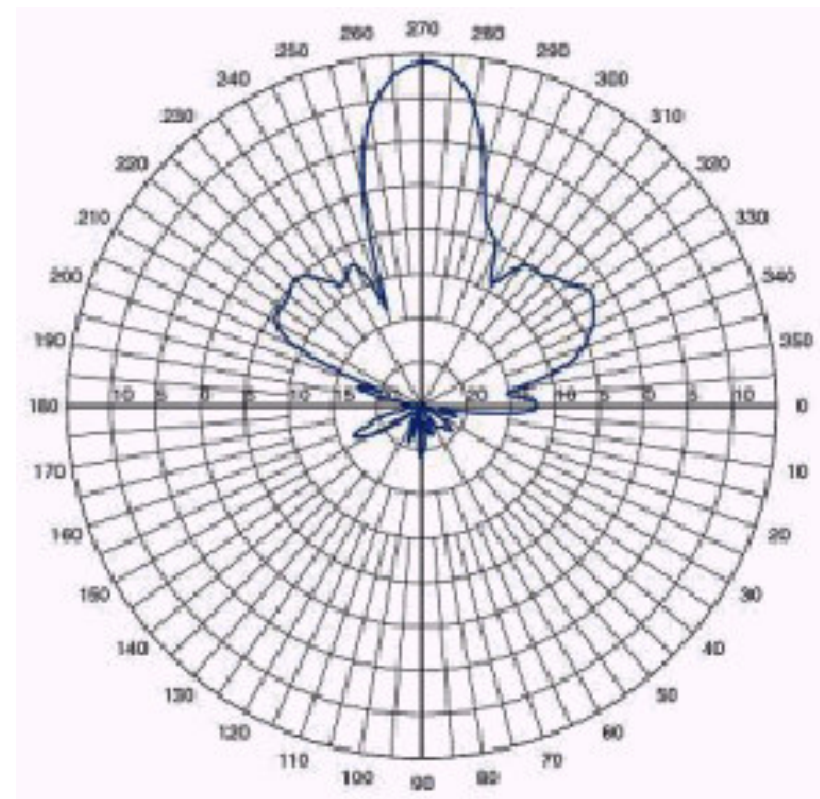
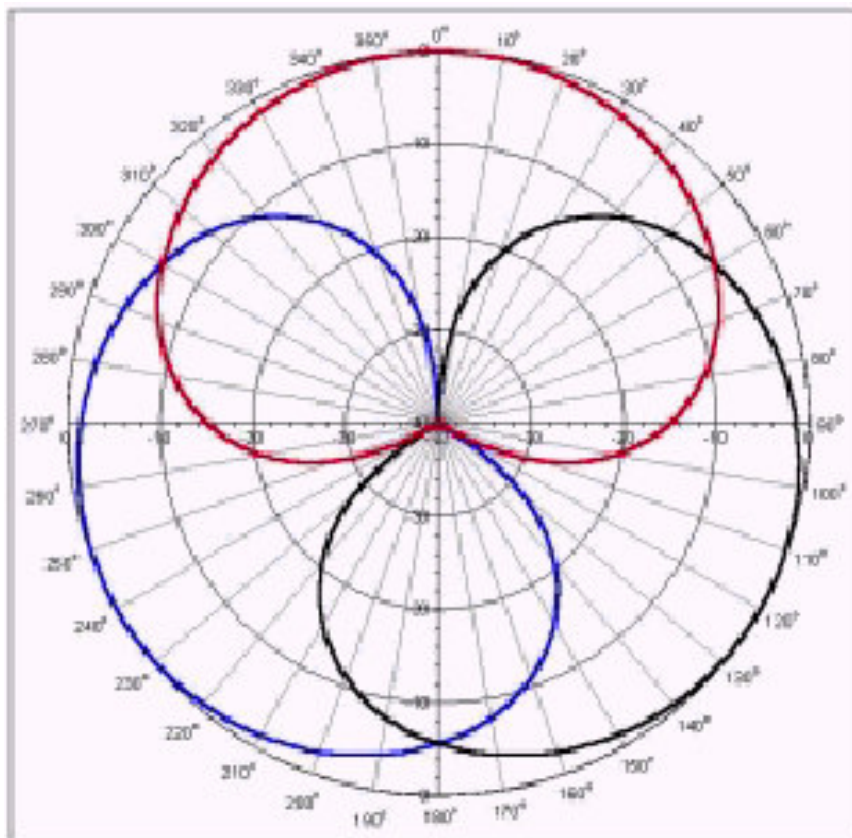



Cisco Yagi Antenna

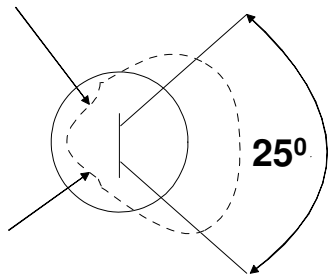

Side View
(Vertical Pattern)

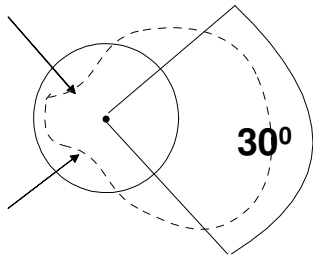

Top View
(Horizontal Pattern)

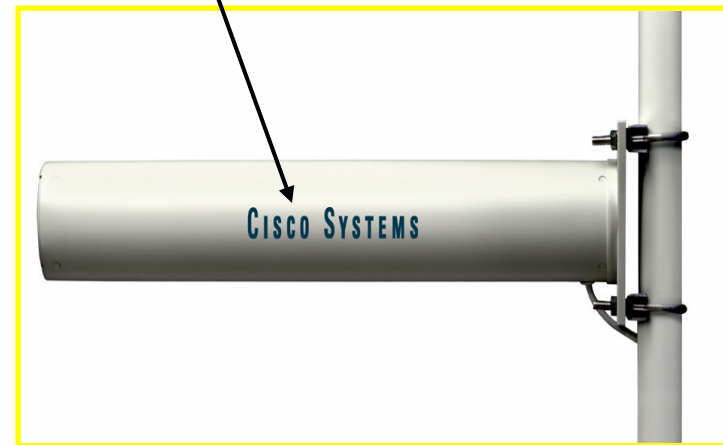

Antenna gain 13,5 dBi



Cisco Directional Antenna

12,4° angle on horizontal and vertical plan

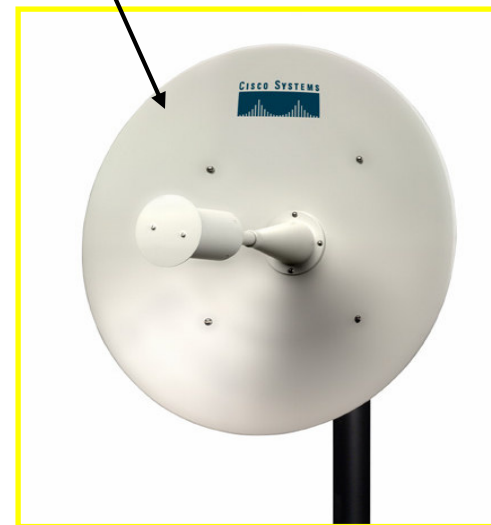
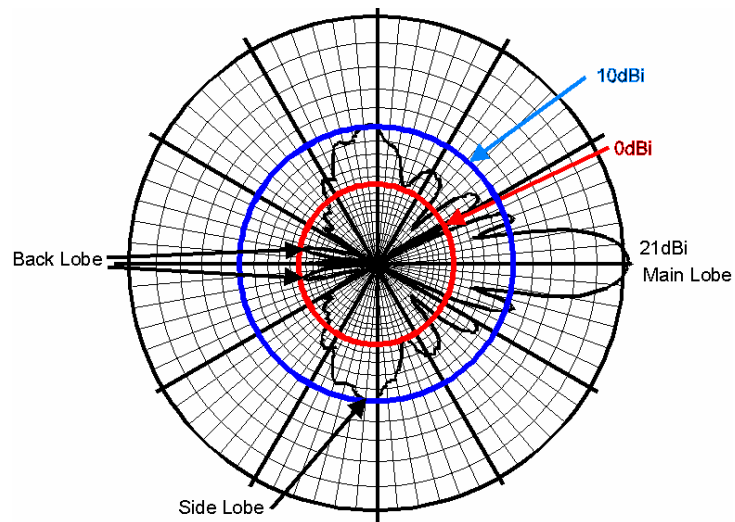



Alvarion Directional Grid Antenna

- Main features:
 - High gain (24 dB)
 - Grid makes suitable for installations in outside windy zones and subject to snowfalls





Alvarion Directional Grid Antenna: Technical Data

Specifications	
	For use with BreezeNET and BreezeACCESS products.
Frequency Range	2400MHz - 2500MHz
VSWR	1.6:1
Gain	24 dBi
Input Power	50 Watts
Beam width H-Plane	6°
E-Plane	10°
F/B Ratio	>30 dB
Cross Pole	>24 dB
Impedance	50 ohms
Polarization	Dual
Termination	With 2ft (0.6m) cable N Type Male connector
Mechanical	
Dimensions	24 x 39 x 15 in.
Weight	5.4 lbs
Maximum Wind Speed	140 mph
Wind Load	@75 mph 63 lbs @140 mph 200 lbs
Reflector Material	Cast Magnesium Alloy
Reflector Type	Parabolic Grid
Elevation Adjustment	60° in 10° increments
Mounting Hardware	Stainless Steel
Mounting	Adjustable Mount Mast Bracket 1 – 2 in. O.D. Pipe



Alvarion Directional Grid Antenna: Technical Data

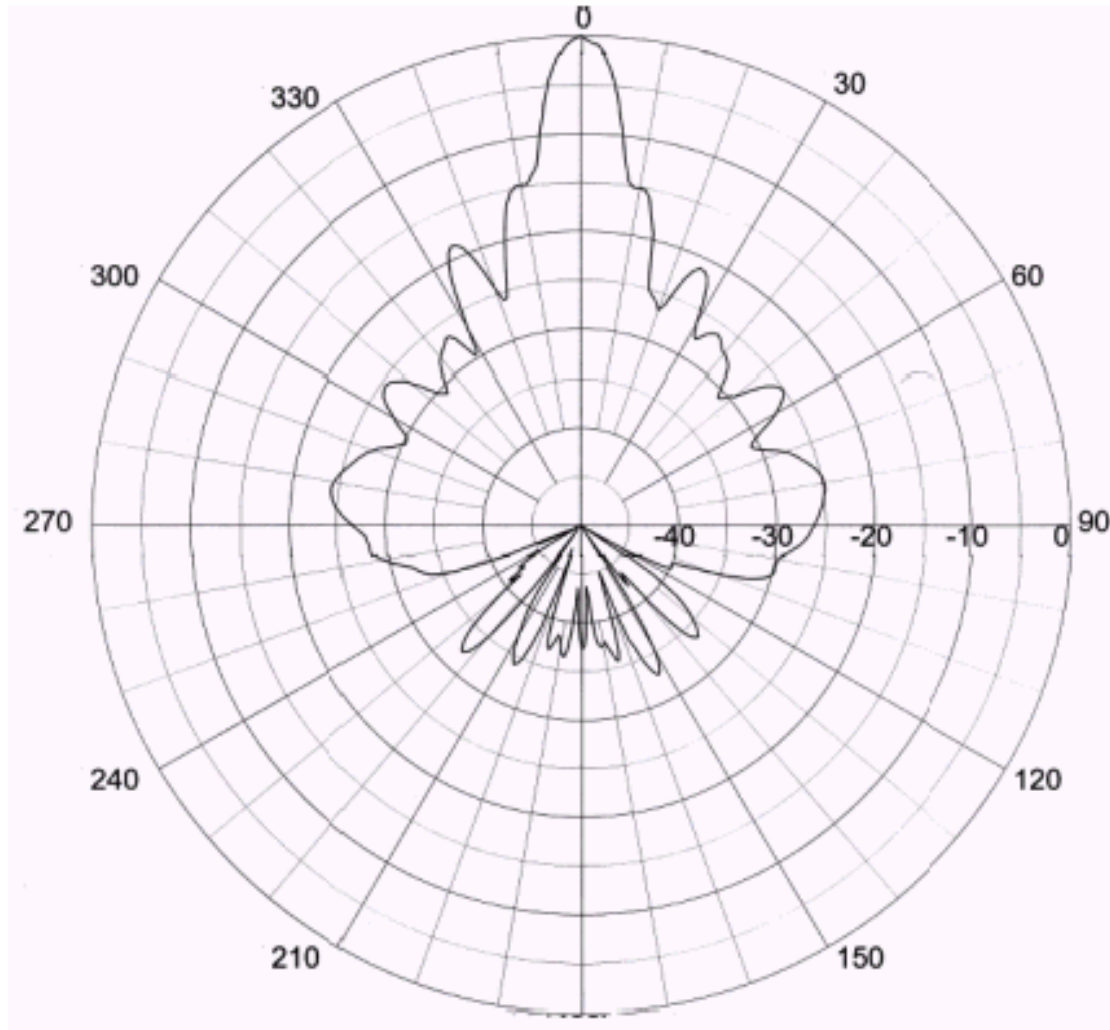



Fresnel Zone

- Fresnel zone is an elliptical area immediately surrounding the visual path. It varies depending on the length of the signal path and the frequency of the signal.
 - The Fresnel zone can be calculated, and it must be taken into account when designing a wireless link.

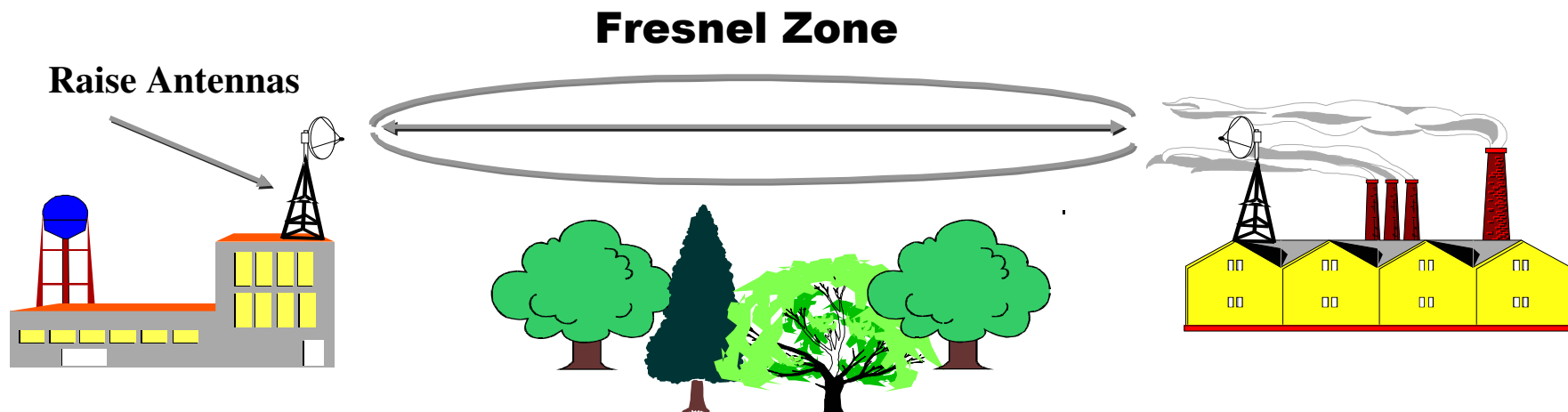



5 GHz in USA and Europe

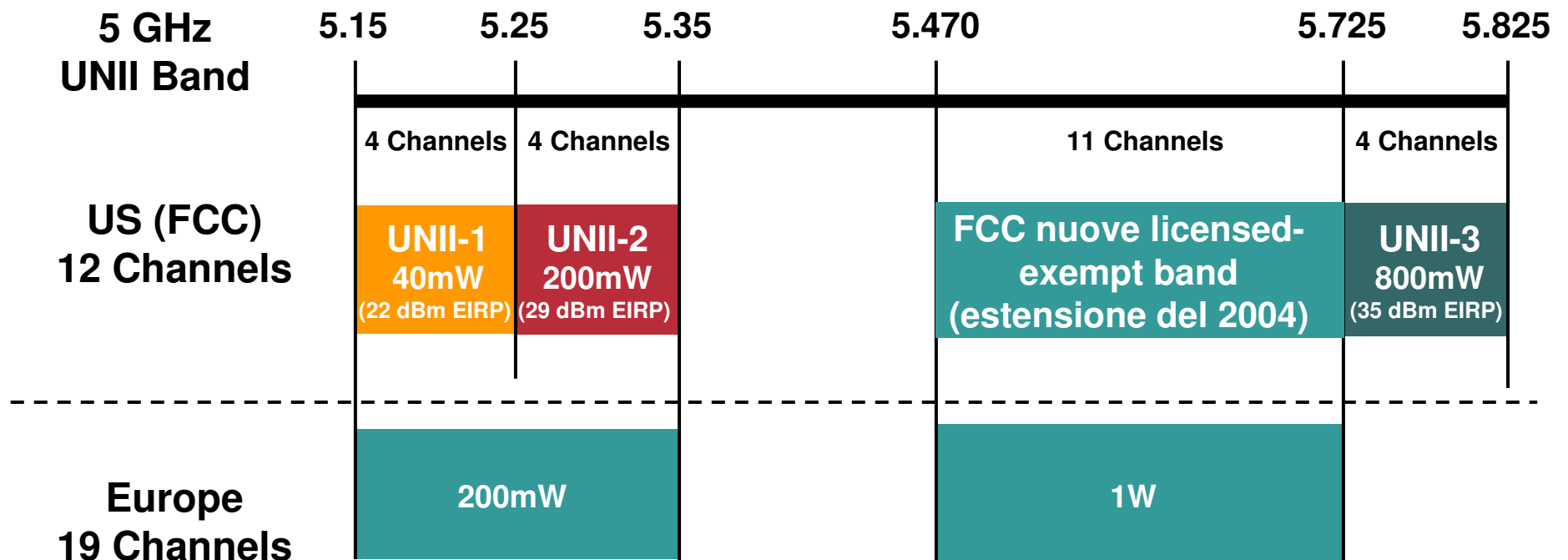



Usable 5 GHz channels in Europe

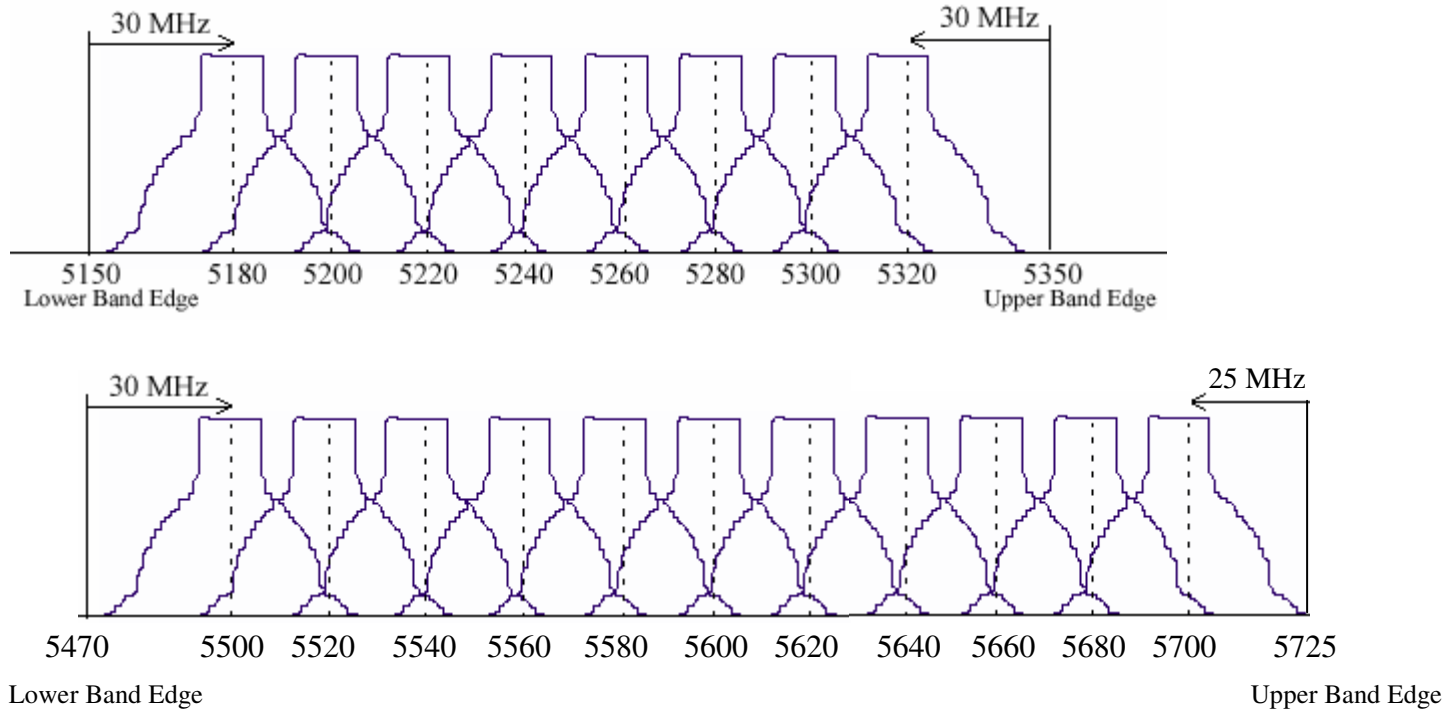



5 GHz channels

Table 94—Valid operating channel numbers by regulatory domain and band

Regulatory domain	Band (GHz)	Operating channel numbers	Channel center frequencies (MHz)
United States <u>CEPT</u>	U-NII lower band (5.15–5.25)	36 40 44 48	5180 5200 5220 5240
United States <u>CEPT</u>	U-NII middle band (5.25–5.35)	52 56 60 64	5260 5280 5300 5320
CEPT	(5.47–5.725)	100 104 108 112 116 120 124 128 132 136 140	5500 5520 5540 5560 5580 5600 5620 5640 5660 5680 5700



Point of retransmission

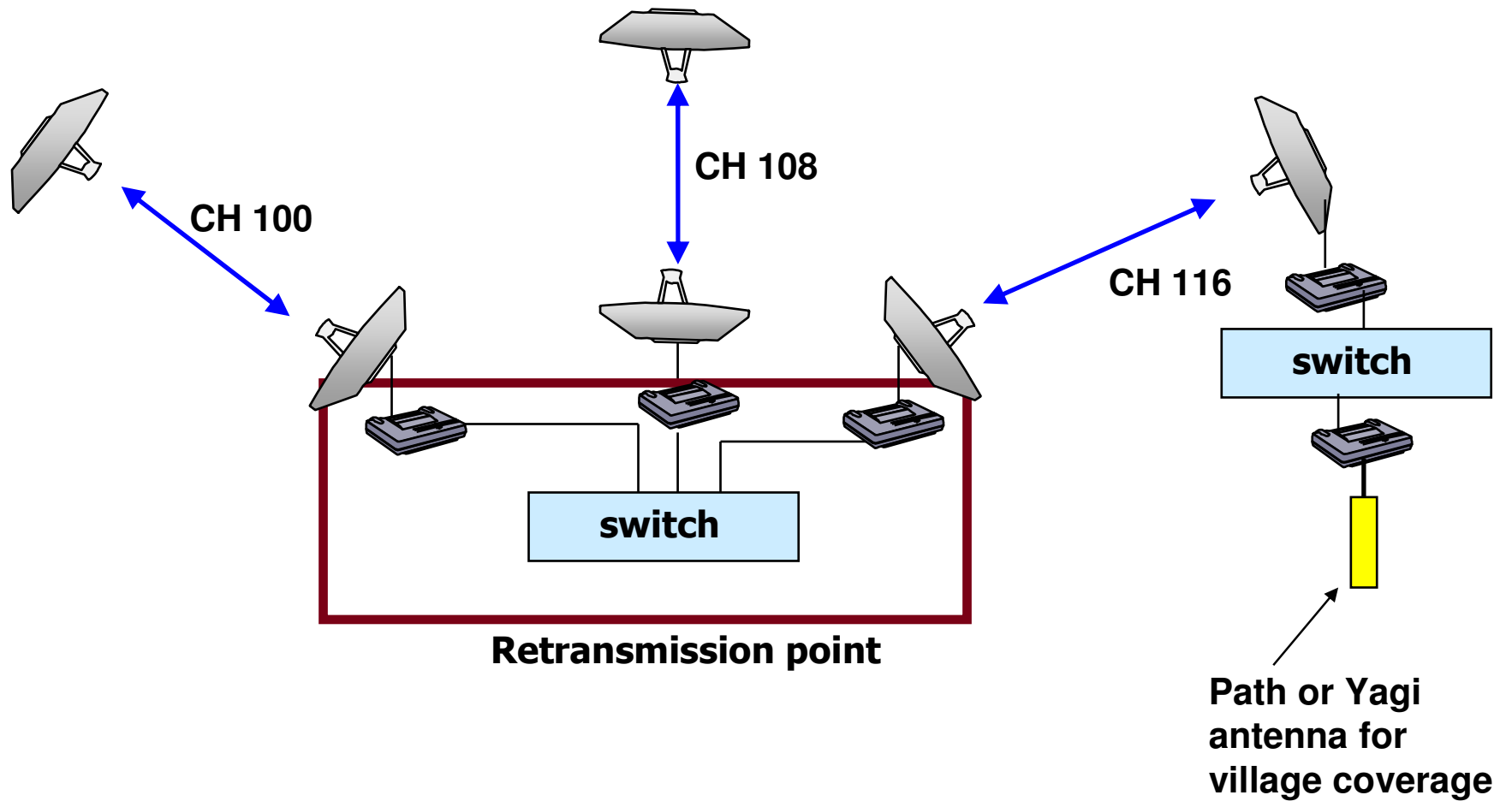



Wireless and mountain

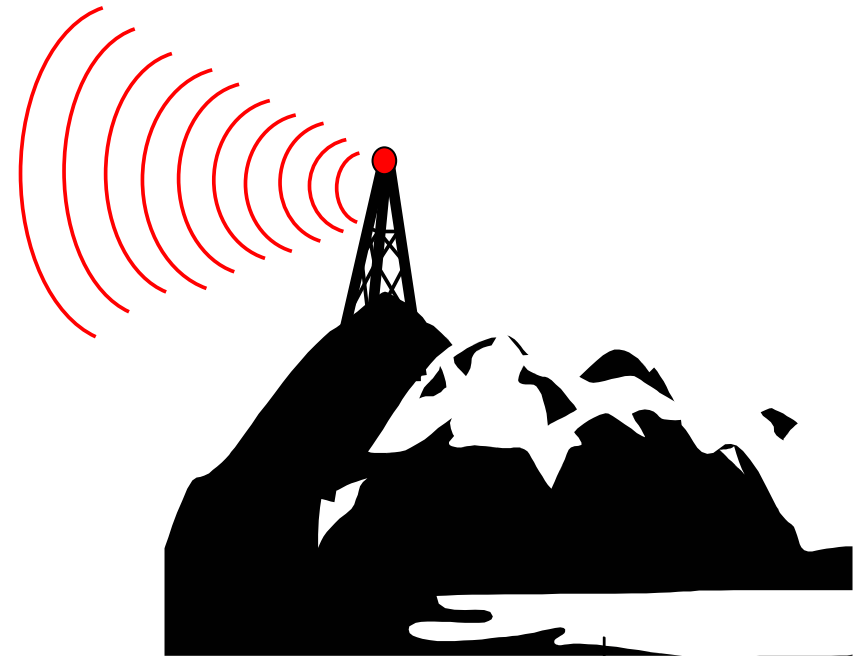
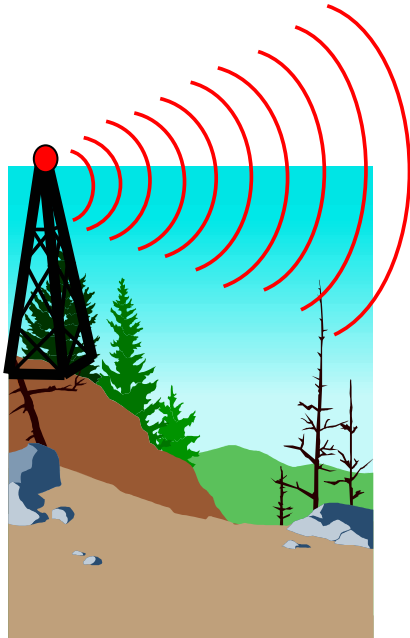



Small village Wireless coverage

